



# CORENET X

A One-Stop Integrated Digital Shopfront for Regulatory Processes

## Code of Practice

Second Edition | Published on 2024-11



**Preamble** 4

**How to use this Code of Practice** 5

 **Section 1:** 6  
Introduction to CORENET X (CX)

 **Section 2:** 12  
General Requirements

 **Section 3:**  
Specific Requirements by

- Regulatory Agencies 25
- Key Gateways 83
- Other Building Works 157

 **Section 4:** 189  
BIM Data Representation (IFC-SG) and Modelling Good Practice

**CORENET X Website and FAQs** 393

**Acknowledgements** 394

# PREAMBLE



CORENET X is a multi-agency effort by



## Preamble

This Code of Practice (COP) is intended to help industry practitioners in understanding how to prepare multi-agency regulatory submissions across the key submission gateways in CORENET X.

This Code of Practice, where relevant, will include recommended procedures and good practices to address common Building Information Modelling (BIM) issues at general project collaboration level (e.g. multi-disciplinary project set-up, geo-referencing) and specific details that vary from firm to firm today.

This Code of Practice complements the IFC-SG Resource Kit (<https://go.gov.sg/ifcsg>), which provides technical templates and help resources from key proprietary BIM software for the generation of IFC-SG models.

## Disclaimer

This Code of Practice details the envisaged end state of CORENET X. CORENET X is developed through Agile Methodology and hence, features and requirements mentioned in this COP will be developed progressively, and its technological enhancements will be made available in phases. For the exact implementation date, please refer to official circulars.

This Code of Practice does not substitute Handbooks, Circulars or other regulatory publications of our regulatory agencies. Readers should refer to the relevant Codes, Acts and Regulations on the compliance required for their projects, before referring to this Code of Practice on how to represent the compliance information in the CORENET X submission gateways.

Readers should consult relevant agencies if they need to determine the regulatory requirements to fulfil compliance.

## Feedback

This Code of Practice will be updated progressively from its Second Edition published in November 2024. Past editions and summary of changes can be found at <https://go.gov.sg/cxcop>. We welcome your comments and queries about the Code of Practice so that we can continue to develop and improve it. Please provide your inputs at <https://go.gov.sg/cxenquiry> or scan the QR code on the right.



<https://go.gov.sg/cxenquiry>

---

<b>Edition</b>	:	Second Edition
<b>Publication Date</b>	:	2024-11
<b>No. of Pages</b>	:	382
<b>Annex</b>	:	Summary of Changes

---

# How to use this Code of Practice

Note: CORENET X is developed through Agile Methodology and sections / requirements in this COP will be updated progressively and its technological enhancements will be made available in phases.

## Section 1: Introduction to CORENET X

- What is CORENET X?
- What are the key aspects of CORENET X?
- What is a user journey of CORENET X like?



## Section 2: General Requirements

- What happens to the QP's statutory obligations under CORENET X?
- What do abbreviations like RABW and IFC-SG stand for?
- What is an example of a CORENET X Submission from project registration to Completion Gateway?

Filter by



### Section 3: Regulatory Agencies

- RABW Requirements categorised by Regulatory Agencies

### Section 3: Key Gateways

- RABW Requirements categorised by Key Gateways

### Section 3: Other Building Works

- RABW Requirements for
  - External Works
  - Direct Submission Process
  - Conservation
  - Part-ST Submissions
  - Infrastructure



Note: Each RABW requirement in Section 3 is complemented by IFC common components from the BIM Model (where relevant)



## Section 4: Typical Components in a Project ("Identified Components")

- What does a BIM component need to contain / look like, in order to satisfy agency's regulatory requirements?

# SECTION 1

## Introduction to CORENET X



# 1 Introduction to CORENET X (CX)

## Page



### **Overview of CORENET X**

- About CORENET X 8
- Today's Separate and Concurrent Approval Process 9
- Tomorrow's Envisaged Streamlined Regulatory Approval Process 10



### **CORENET X User Journey**

11



A future *ecosystem* of Regulatory Approval of Building Works that accelerates the transformation of the Construction Industry

## About

Harnessing the power of digitalisation and technology, CORENET X will allow Qualified Persons (QPs, i.e. professional engineers and registered architects) to submit a three-dimensional model of a development or building - created and developed digitally through Building Information Modelling (BIM) to the regulatory agencies.

It allows the project team, which includes the QPs, to collaborate and review their designs in the model together, detect possible major conflicts before construction, and produce a coordinated BIM model for submission and regulatory approval. It changes the current practice of QPs dealing separately with multiple regulatory agencies, and producing different versions of building plans thereafter.

Led by BCA and URA and supported by GovTech, CORENET X was developed in close collaboration with the other public agencies<sup>1</sup> and leading built environment professionals, firms, and Trade Associations and Chambers (TACs). It was soft launched on 18 December 2023.

See also:

[Minister \(MND\)'s Official Announcement of CORENET X at the International Built Environment Week 2021](#)

[CORENET X Circulars](#)

<sup>1</sup> CORENET X comprises of the following public agencies: BCA, URA, GovTech, HDB, JTC, LTA, NEA, NParks, SCDF and SLA.



# Today's Separate and Concurrent Regulatory Approval Process

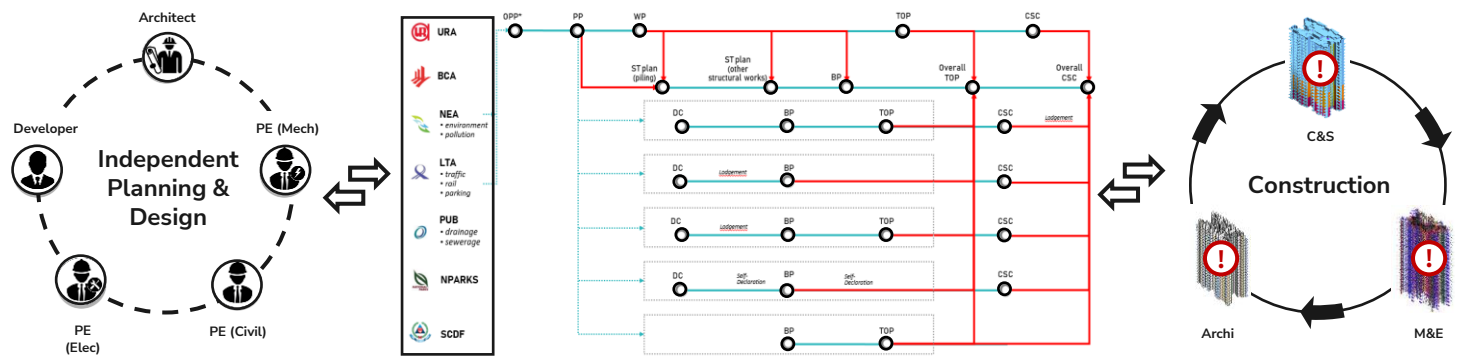

- Plans are prepared by **different professionals independently**
- Plans are **submitted separately** to different agencies at different milestones concurrently

- Each of the 7 agencies has a **different regulatory mandate**
- Comments from one agency may lead to **resubmission/ amendment** to others
- Approved plans can be **conflicting; no single integrated view** of the approved plan

- Plans contain **conflicts that need to be resolved** during construction
- Rectifications = **Abortive Works**
- **Delayed issuance** of TOP/CSC

A key impetus for change is because of today's fragmented approval process. In today's process, the industry prepare submissions independently, and they then submit these plans separately to the different regulatory agencies.

This silo working environment is not conducive for coordinated design and regulatory reviews upstream, which often results in iterative submissions as well as conflicting or disjointed building information downstream during construction. This leads to abortive works, or resubmissions which delays TOP/CSC, ultimately affecting construction productivity.

See also:  
[Latest CORENET X Circulars](#)

# Tomorrow's Envisaged Streamlined Regulatory Approval Process

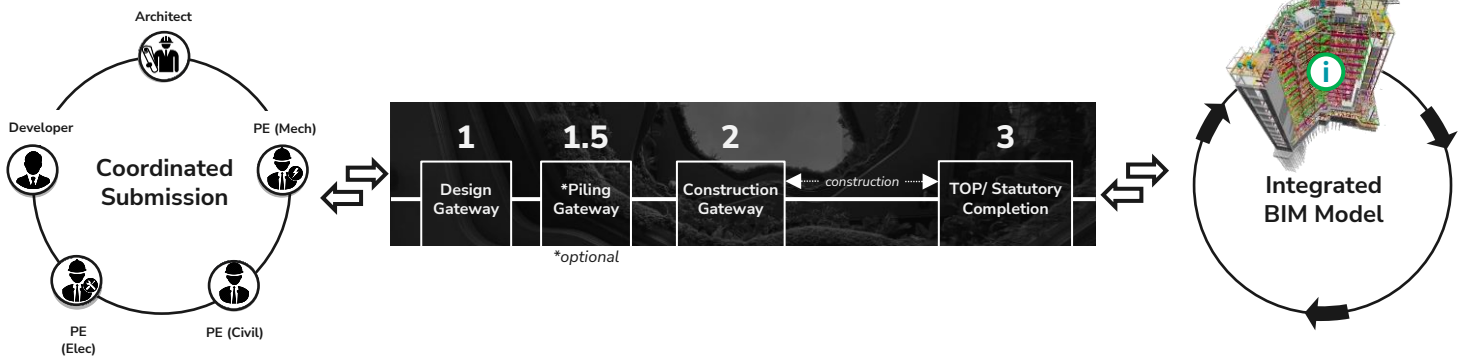

- Industry will need to **collaborate upfront with one another prior to submission**
- The Qualified Persons (QPs) will **submit Coordinated BIM Models** at the Gateways instead of submitting independently

- Over 20 approval gateways have now been streamlined to **3 Key Gateways: Design, Construction, Completion**
- These gateways are major submission milestones, where the submitted design needs to comply with cross-agencies' statutory requirements.
- Agencies will review the Coordinated BIM models together in a common data environment.

- Construction rectifications arising from competing regulatory requirements would be minimised as major conflicts would have been surfaced and resolved upstream prior to construction.

We wanted to radically rethink how the regulatory services can be delivered in a project centric manner, instead of today's silo manner. In tomorrow's process, industry will submit coordinated BIM models to the agencies for review, instead of submitting independently. The earlier 20 over approval gateways have now been streamlined to **3 key gateways**.

See also:  
[Latest CORENET X Circulars](#)

# CORENET X User Journey

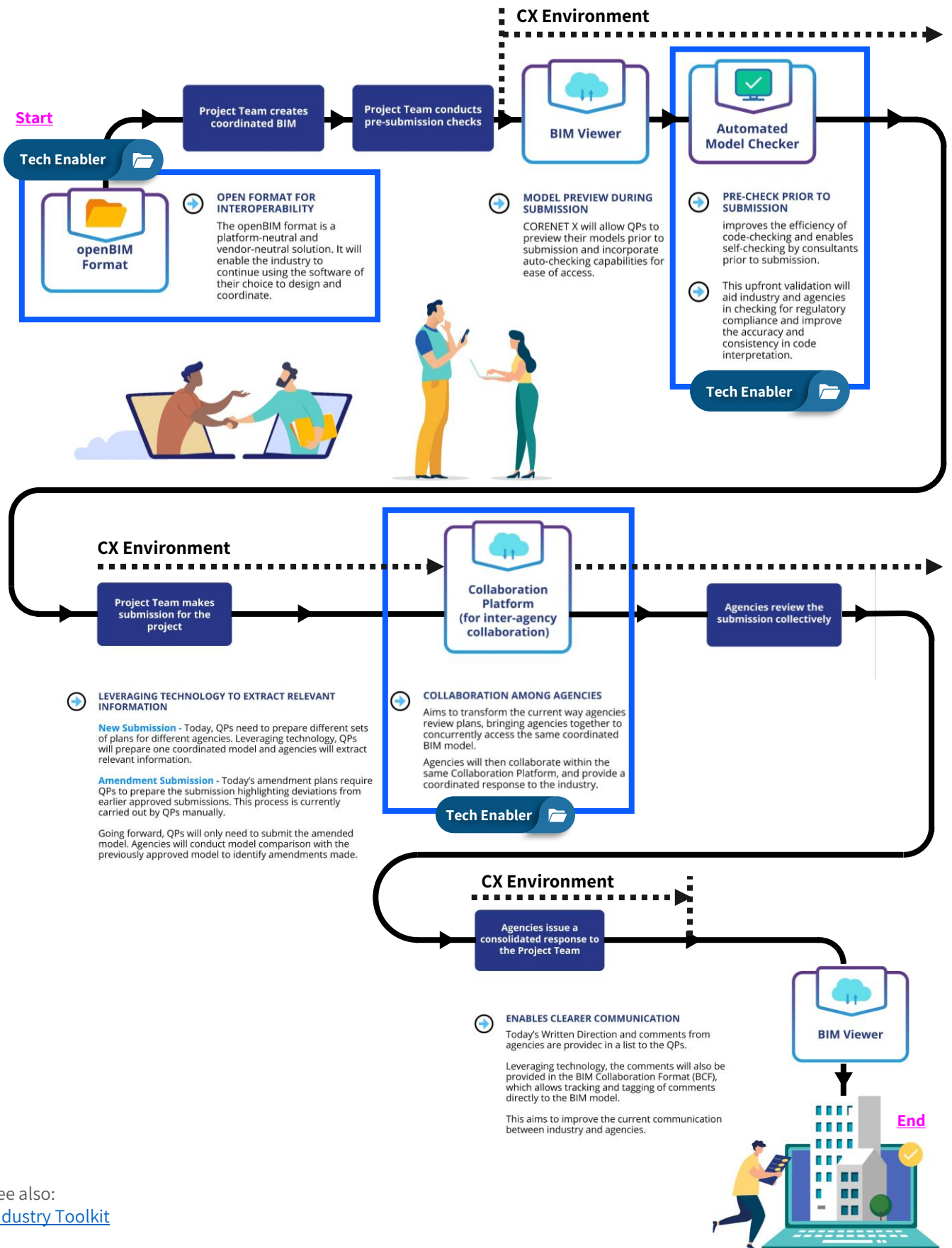



See also:  
[Industry Toolkit](#)

# SECTION 2

## General Requirements



## 2 General Requirements

	<b>Page</b>
 <b>QP's Statutory Responsibilities, Terms and Definitions</b>	14
 <b>New CORENET X Submission Workflows</b>	
• Typical Submission Package at a Single Gateway	15
• New and Amendment Submission Workflow	17
• Example of a Project Team's Submission Workflows	19
• Introduction of Checksums for Approved Plans	23

## QP's Statutory Responsibilities

While the regulatory approval process is being redesigned to improve the current user experience to navigate across multiple regulatory agencies, the regulatory agencies' respective mandate and regime remains unchanged. Hence, the statutory responsibilities of the appointed QPs under the respective Acts and Regulations **remains unchanged**.

Under the RABW, part of the process requires joint submission by the relevant QPs within the project teams to the relevant regulatory agencies. To ensure clear delineation of responsibilities, the developer (or whoever is required under the respective Acts and Regulations) needs to first appoint the QP for the respective areas of work at the start of a project. The appointed QP will then be responsible for the relevant aspects of the submission.

## Terms and Definitions

For the purpose of this Code of Practice, the following definitions shall apply:

Term	Definitions
<b>RABW</b>	Abbreviation for "Regulatory Approval Process for Building Works", and refers to the new process involving 3 key sequential submission gateways to all Agencies for one collective and coordinated approval at each gateway.
<b>Gateways</b>	Major submission milestones in CORENET X, where the submission needs to comply with multiple agencies' statutory requirements at each Gateway. <ul style="list-style-type: none"> <li>Multiple <u>Agency</u> requirements listed under each regulatory agency can be found <a href="#">here</a>.</li> <li>Multiple <u>Key Gateway</u> requirements listed under each gateway can be found <a href="#">here</a>.</li> </ul>
<b>Supporting Mechanisms</b>	Similar to today, there are 3 supporting mechanisms will continue to complement the approval process: <ol style="list-style-type: none"> <li><b>1. Pre-Submission Consultation</b> <ul style="list-style-type: none"> <li>Pre-submission consultation will continue to be available for industry to consult or seek clarification prior to submission.</li> </ul> </li> <li><b>2. Waivers</b> <ul style="list-style-type: none"> <li>Where necessary, the industry may apply for waiver under the respective Act and Regulations and the respective agency will assess the applications accordingly.</li> </ul> </li> <li><b>3. Escalation Mechanism</b> <ul style="list-style-type: none"> <li>Industry can table their case to seek resolution on inter-agency regulatory conflicts at the Inter-agency Coordinating Committee (IACC).</li> </ul> </li> </ol>
<b>Federated Model</b>	Combined Building Information Model that compiles multiple models from different disciplines or sections of the project into a single, complete model of the project. <ul style="list-style-type: none"> <li>Federated models support concurrent authorship of different aspects of the project by multiple parties.</li> <li>Federated models also support multi-disciplinary coordination as models are geo-referenced to coordinates from the Singapore SVY21 coordinate system (EPSG: 3414) for Easing and Northing (x,y) and Singapore Height Datum (SHD) for Height (z).</li> </ul>
<b>IFC-SG</b>	New representations for local regulatory requirements, in the Industry Foundation Classes (IFC) openBIM standard. More information of the mapping and configuration files for IFC-SG can be found <a href="#">here</a> .
<b>Level of Details</b>	As long as relevant IFC-SG data requirements are embedded in the respective BIM components and minimum dimensions represented, BIM components do not need to replicate their real-life equivalent. <p>For example, trees can be represented as a lollipop object as long as IFC-SG parameters like "Girth", "Height" and "Status" are represented.</p> 
<b>Non-BIM submissions</b>	Besides BIM submissions in the IFC-SG format, CORENET X will be able to accept non-BIM submissions.
<b>Supplementary Documents</b>	CORENET X will be able to accept non-BIM documentations that accompany each project team's submission of IFC-SG models (e.g. design calculation reports, 2D supplementary drawings)

## Typical Submission Package at a Single Gateway

The following tables below show samples of what are inside typical CORENET X submission packages in a Design Gateway, Piling Gateway and Construction Gateway.

The purpose of this illustration is to highlight that not everything in CORENET X will have to be modelled in 3D. For practical reasons, it may not make sense to expect complex details to be modelled, and hence the submission package will also consist of other supporting documents such as 2D detailed drawings, design calculation reports etc.

We have highlighted in the yellow boxes examples of what may be required. Note that this differs across project types and is not exhaustive.

### ► Sample of a Design Gateway Submission Package

Examples	Architecture	C&S Engineering	M&E Engineering
IFC-SG models, all geo-referenced	<ul style="list-style-type: none"> <li>Blk 1 Model</li> <li>Blk 2 Model</li> <li>Site Model</li> </ul>	<ul style="list-style-type: none"> <li>Modelling components provided by C&amp;S, such as an entrance culvert, box drain, where applicable</li> </ul>	<ul style="list-style-type: none"> <li>Sanitary Model indicating last Inspection Chamber and other PUB Design Gateway requirements</li> </ul>
Refer to <a href="#">Section 4</a> , on ensuring quality (e.g. coordination) of models for submission.			
2D drawings	<ul style="list-style-type: none"> <li>Topographical Survey Plan</li> </ul>		
Other documents	<ul style="list-style-type: none"> <li>Connectivity (Walking and Cycling) Plan</li> <li>Site photographs</li> </ul>		

### ► Sample of a Piling Gateway Submission Package

Examples	C&S Engineering
IFC-SG models, all geo-referenced	<ul style="list-style-type: none"> <li>Substructure Model (For foundation and piling works)</li> </ul> <p>Note:</p> <ul style="list-style-type: none"> <li>It is optional to submit in the Piling Gateway.</li> <li>For projects which did not opt for Piling Gateway (G1.5), the project team will need to include all permanent foundation works in Construction Gateway (G2).</li> <li><a href="#">Larger projects may be eligible to make Part ST Submissions</a></li> </ul>
Refer to <a href="#">Section 4</a> , on ensuring quality (e.g. coordination) of models for submission.	
2D drawings	<ul style="list-style-type: none"> <li>General notes</li> <li>Special details (e.g. irregular or complex footing/pilecap design (e.g. 3 pile group, stair core pile group, etc.) with the indication of drawing number in the IFC-SG parameter “ReferTo2DDetail”.)</li> </ul>
Other documents	<ul style="list-style-type: none"> <li>Design calculation reports from QP, AC, [QP(Geo) &amp; AC (Geo), if needed]</li> <li>Site Investigation report in pdf &amp; AGS format</li> <li>Impact assessment report</li> <li>Topography</li> <li>Completion letter of pre-consultation (for complex structure only)</li> </ul>

## Typical Submission Package at a Single Gateway

### ► Sample of a Construction Gateway Submission Package

Examples	Architecture	C&S Engineering	M&E Engineering
IFC-SG models, all geo-referenced	<ul style="list-style-type: none"> <li>Blk 1 Model</li> <li>Blk 2 Model</li> <li>Site Model</li> </ul>	<ul style="list-style-type: none"> <li>Blk 1 Model</li> <li>Blk 2 Model</li> </ul> <p>Note:</p> <ul style="list-style-type: none"> <li>For projects which did not opt for Piling Gateway (G1.5), the project team will need to include all permanent foundation works in Construction Gateway (G2).</li> <li><a href="#">Larger projects may be eligible to make Part ST Submissions</a></li> </ul>	<ul style="list-style-type: none"> <li>Blk 1 Model</li> <li>Blk 2 Model</li> <li>Main Model (ground and substructure levels)</li> </ul>
	Refer to <a href="#">Section 4</a> , on ensuring quality (e.g. coordination) of models for submission.		
2D drawings	<ul style="list-style-type: none"> <li>Topographical Survey Plan</li> <li>Details (e.g. household / storey shelter documentation and detailing)</li> <li>External Works</li> </ul>	<ul style="list-style-type: none"> <li>General notes</li> <li>Special details (e.g. slab reinforcement detailing, complex structure detailing, precast joints, prestressed details, steel connections)</li> <li>External Works</li> </ul>	<ul style="list-style-type: none"> <li>Details (e.g. cooling tower documentation and detailing)</li> <li>External Works</li> </ul>
Additional documents	<ul style="list-style-type: none"> <li>B-Score BS01 form</li> <li>Public Communication Plans (if applicable)</li> </ul>	<ul style="list-style-type: none"> <li>B-Score BS01 form</li> <li>Design calculation reports from QP, AC, [QP(Geo) &amp; AC (Geo), if needed]</li> <li>Catchment Plan</li> <li>Completion letter of pre-consultation (for complex structure only)</li> </ul> <p>Supporting documents for piling works:</p> <ul style="list-style-type: none"> <li>Site Investigation report in pdf &amp; AGS format</li> <li>Impact assessment report</li> <li>Topography</li> </ul>	<ul style="list-style-type: none"> <li>B-Score BS01 form</li> <li>Pollution Control Study (PCS) reports</li> <li>SCDF waiver decision letter</li> </ul>



## New Submission

### ► Joint Submission Workflow

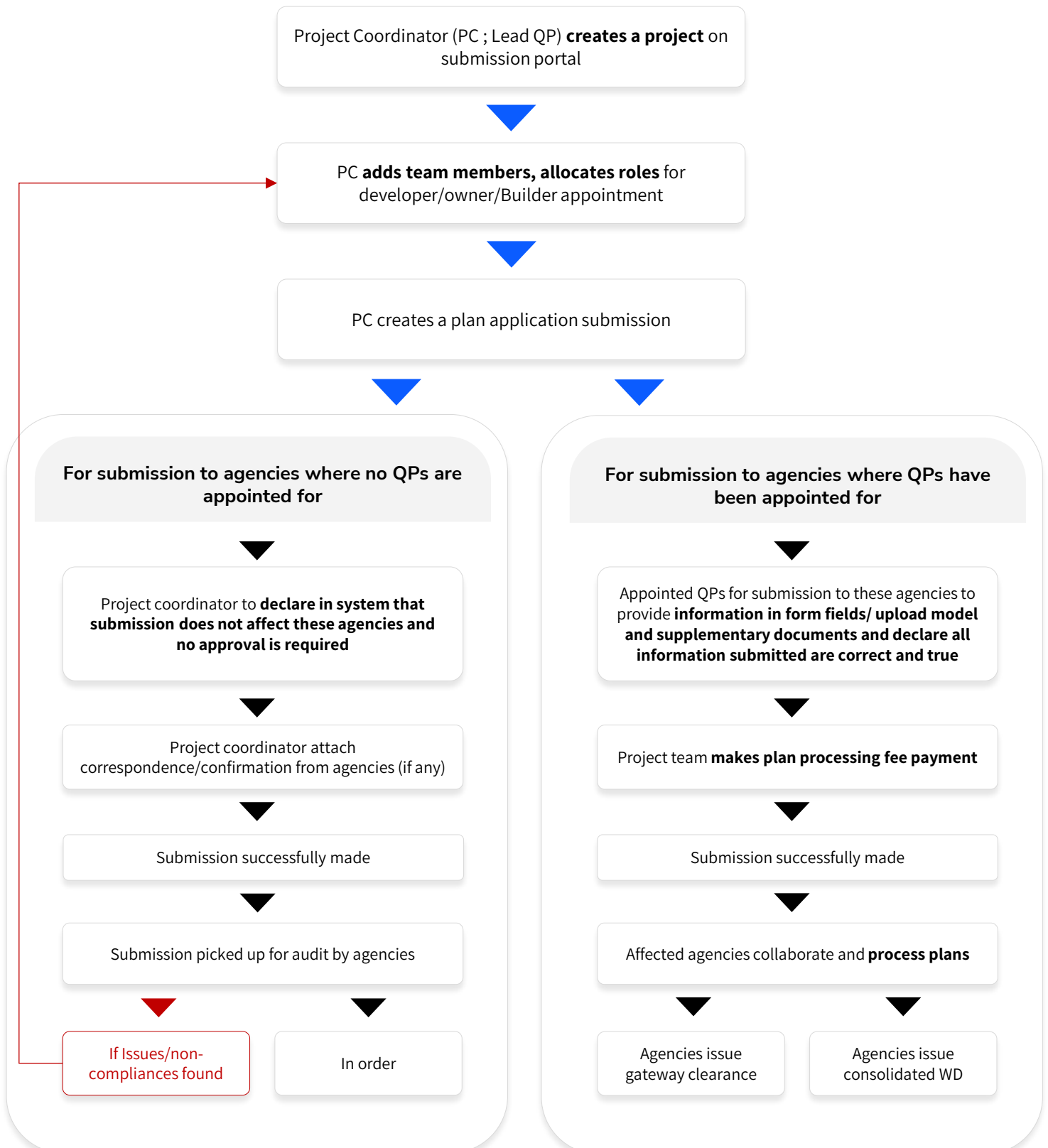

## Amendment Submission

### ► Joint Submission Workflow

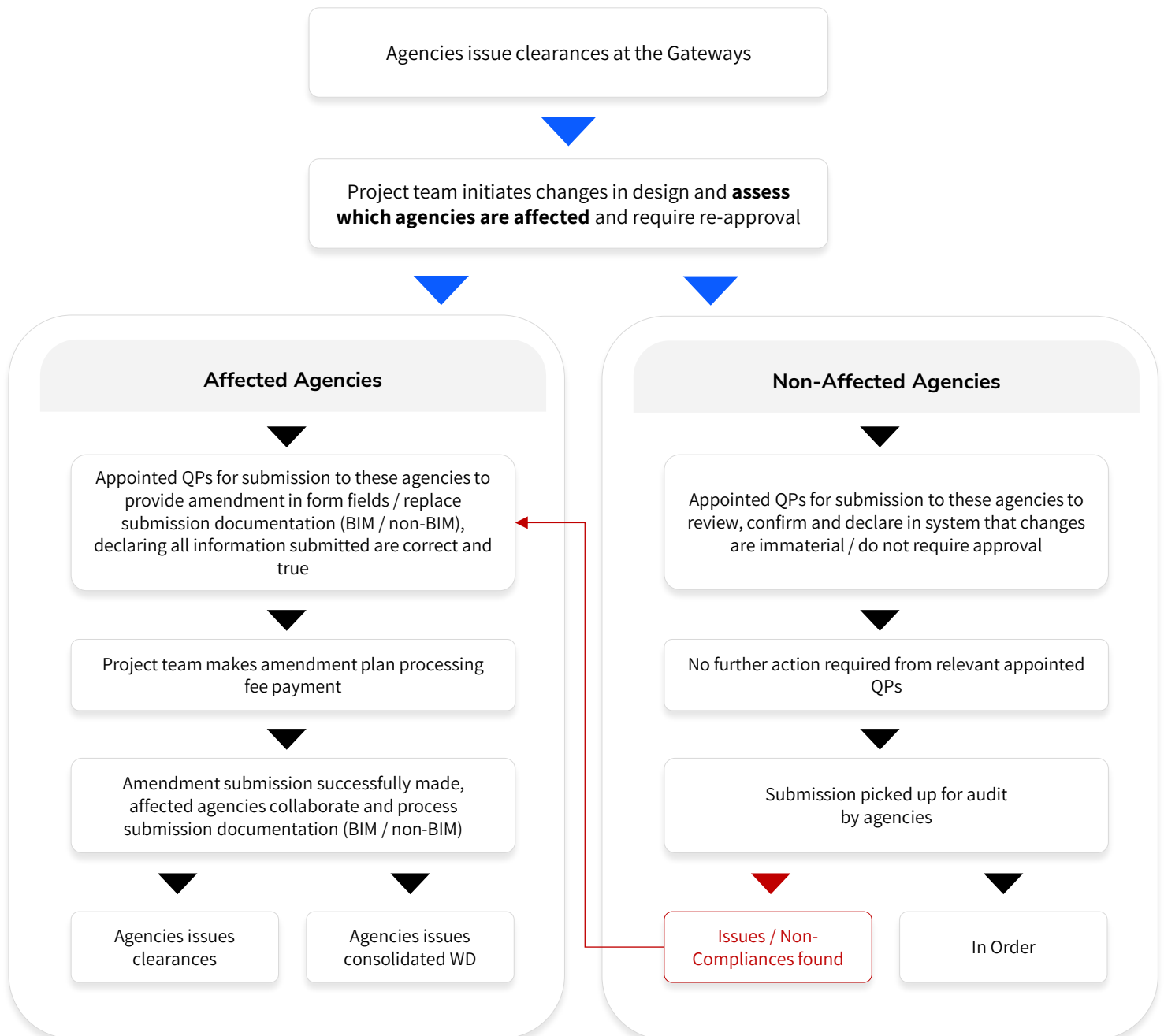

## Example of a Project Team's Submission Workflows

### 1. Register project on CORENET X Submission Portal

<https://portal.corenet.gov.sg/>

#### Good Practices

- Ensure all project members have set up Singpass for Business (Corppass) settings if they are representatives from an organization, including Corppass access to the CORENET X Submission Portal (<https://portal.corenet.gov.sg/>)
- The project team should collaborate and agree on roles and responsibilities of respective QPs required each project
- The Project Coordinator should support / receive support to/from the project team members and assistants for smooth onboarding of all submissions.
- Within each organization, ensure relevant IT and Finance colleagues are notified of the organization's roles in the project, to avoid unnecessary delay to the rest of the project team during submission preparations



#### Useful References

- <https://www.corppass.gov.sg/corppass/communities/digitalservice/elist>

### 2. Carry out Pre-submissions and Pre-Consultations

#### Good Practices

- All project team members should plan carefully on the types of submissions the project will undergo, and the timing, party / parties and format(s) involved in each submission
- There are Pre-Submissions (e.g. NParks EMMP, NEA NIA) that are to be submitted by email and not via CORENET X Submission Portal – read the Code of Practice carefully for more info.
- Projects requiring JTC Land Consent can apply via CORENET X.
- Projects are encouraged to carry out pre-consultations for household / storey / transit shelter compliance
- Project team members are encouraged to carry out pre-submission consultations as early as possible, to clarify or enquire on agency requirements, potential deviations.
- Do not forget to indicate your query in the CORENET X pre-consultation submission form. The more details and information you attach in the query, the more agencies can assist and expedite your query.

### 3. Submit for Demolition, if applicable

#### Good Practices

- Discuss with the project team if there is a need to submit for Demolition before or after submitting for a Design Gateway or Direct Submission Process submission. (Note that there will be a difference in fees based on timing of demolition submission on CORENET X)
- If submitting prior to the Design Gateway or Direct Submission Process, the demolition submission will be a joint submission to BCA and URA.
- It is optional to submit in 3D.

(continued on next page)

## Example of a Project Team’s Submission Workflows

(continued from previous page)

### 4. Submit for Design Gateway or Direct Submission Process (DSP)

#### Good Practices

- If you are unable to find a particular agency’s form for your Design Gateway or Direct Submission Process, review the respective QP’s roles and responsibilities, and initiate Developer’s appointment for missing scopes to open the missing form.
- After you have indicated project information in the form inputs, the Submission Portal will show whether you can submit for Lodgement.
- Utilise the “Fee Computation” feature to double-check that Submission Portal inputs for submission requiring fee payments are correctly filled in
- Fees below \$10,000 are encouraged to be paid via credit card
- There is no 72-hour deadline for payment of fees after submission. However, processing will only commence after relevant fee payments have been completed by the project team and verified by relevant agencies.
- Remember to indicate and check the last I/C and minimum platform levels in the Design Gateway IFC-SG models have been indicated and are accurate, double-checking that the levels are the same as indicated in the Submission Portal form
- Where applicable, project teams are encouraged to upload models early to utilize the “Preview Model” feature on the Submission Portal, to ensure models are geo-referenced and coordinated accurately prior to submission.
- It is not necessary to indicate “Magenta”, “Cyan” and “Yellow” colours to reflect “New”, “Existing”, and “Removed” elements in BIM models for A&A or Conservation projects. Instead, relevant IFC-SG parameters (e.g. Status parameter) should be populated for relevant elements accordingly.
- It is possible for larger projects (e.g. MRT Stations) to submit for both Design Gateway and DSP concurrently (e.g. Design Gateway for the Station Box and DSP for the Pedestrian Overhead Bridge)
- It is possible to submit for Demolition after the 1<sup>st</sup> Design Gateway or DSP Submission. Approval will only be granted after URA Lodgement or approval has been obtained.
- It is possible to submit for advance comments by respective agencies for Piling and/or Construction Gateway after the 1<sup>st</sup> Design Gateway Submission. Approval will only be granted after Design Gateway Approval has been obtained.

### 5. Obtain Written Directions and Make Resubmissions

#### Good Practices

- Relevant agencies will provide Written Directions or Approvals after a Service Level Agreement of up to a maximum of 20 working days.
- For joint submissions, only agencies with WDs will issue responses – agencies who are ready to issue approval will not respond until the subsequent resubmission where all relevant agencies are agreeable to approve
- Written Directions for BIM submissions will also include a BIM Collaboration Format (BCF) zip files. Free BCF plugins and apps are available to view the BCF files in native BIM software.
- Do not upload outdated documents (including models and plans) into the resubmissions
- Fee top-ups (e.g. after wrong form inputs or change from lodgement to processed submission) can be made during re-submissions.

(continued on next page)

## Example of a Project Team's Submission Workflows

(continued from previous page)

### 6. Obtain Approvals and Make Amendments

#### Good Practices

- Joint Submission approvals consist of individual approval/clearance letters of relevant agency line departments.
- When a submission is ready for approval, agencies will generate digital checksums for approved documents requiring agency authentication (as a more secure replacement for agency watermarks)
- It is possible to make amendments for all approvals except Design Gateway. Immaterial changes to Design Gateway approved submissions may be submitted in the Construction Gateway. When in doubt, the project team should clarify with the relevant agency / agencies.
- Major changes to the Design Gateway approved submission will require a re-submission to the Design Gateway

### 7. Submit for Piling Gateway

#### Good Practices

- The Piling Gateway is an optional gateway for projects who require piling works to start earlier onsite prior to Construction Gateway submission
- It is possible to submit Piling Gateway and Construction Gateway concurrently.
- Piling Gateway submissions comprise of BCA (ST), and may be a joint submission with LTA (Rail) if applicable
- The project team, including the builder where applicable, should discuss early on how part-ST submissions should be carried out prior to pre-consultation with BCA
- Ensure the Accredited Checker (AC), PE (Geo), AC (Geo) are onboarded, appointed and aware of their roles in the projects, where applicable.
- Resident Engineers (REs) and Resident Technical Officers (RTOs) can be directly added by the C&S Engineer on the Submission Portal. The Project Coordinator and Developer do not need to get involved in their additions.

### 8. Submit for Independent Submissions and Waivers

#### Good Practices

- Independent Submissions are technical submissions to one agency line department without affecting other agencies (e.g. ERSS works, Fire Protection/Mechanical Ventilation Plans)
- Waivers can be applied on the CORENET X Submission Portal.
- Independent Submissions can be submitted in the non-BIM format
- It is important to understand when and which Independent Submissions can be submitted for your project. Pls study the Code of Practice carefully, and clarify with agencies early if in doubt. Wrong assumptions of Independent Submissions and Waivers may lead to delays in the project timeline.

(continued on next page)

## Example of a Project Team’s Submission Workflows

(continued from previous page)

### 9. Submit for Construction Gateway

#### Good Practices

- Preparations for Construction Gateway should start as early as possible, due to the number of regulatory departments involved.
- The project team, including the builder where applicable, should discuss early on how part-ST submissions should be carried out prior to preconsultation with BCA
- Regardless of part-ST submissions, the first Construction Gateway submission must include full Architectural and M&E submission models, as well as the full C&S model “carcass” (geometrically accurate model without embedded IFC-SG data)
- Besides Construction Gateway requirements as stated in the Code of Practice, project teams must remember to incorporate Design Gateway Approval instructions and notes related to Construction Gateway submissions.
- External Works should be submitted together with the first Construction Gateway Submission, but the approvals for External Works will be delinked from the Construction Gateway Approval
- Formal approvals for IRAS Certificate of Numbering and BCA Share Value will take place after Construction Gateway Approval

### 10. Completion Gateway

#### Good Practices

- The Completion Gateway consists of a one-stop dashboard of the project’s status of TOP/CSC applications across various agencies shown on the CORENET X Submission Portal
- TOP submissions are to be made to respective agencies independently and concurrently, whenever ready.
- The final TOP/CSC will be issued when the project obtains all the necessary clearances of various agencies.
- If IFC models had been submitted earlier in CORENET X for the project, as-built submissions will consist of latest updated IFC models, with IFC-SG data updated upon the earlier approved models to respective agencies.
- Verify the 2D and 3D documentation required for the Completion Gateway, especially if they are created by parties onboarded later in the project
- Note that there are submissions made to The PUB Business & Professional portal and LTA PROMPT service portal, such as the QECP Plan, submissions related to sewer corridor activities and road access opening submissions.



Always check circulars for latest CORENET X updates, changes/additions to agency requirements as well as any other initiatives that affect regulatory submissions



IMDA TFCC, City Energy and SP PowerGrid submissions will continue to be submitted through CORENET 2.0. In the future, these submissions will be covered under CORENET X.

## Introduction of Checksums for Approved Plans

### ► What is a Checksum?





A checksum is an alphanumeric value that uniquely represents the contents of a file. It is akin to the digital fingerprint of the file.

In the approval response, the QP will find a “List of Approved Plans” by each agency. The QR representation of the Approved Plan’s checksum will be listed in the “List of Approved Plans” (1 unique checksum per file).

**List of Approved Plans (BCA)**

PROJECT REFERENCE NO.: [REDACTED]  
 PROJECT TITLE: [REDACTED]

This list of Approved Plan(s) shall be read in conjunction with the accompanying Notice of Approval/Clearance.

ALL Coordinated BIM		
-AR- ifc	Sanitary Plan.ifc	-STR- ifc
		
BCA Structural Works		
.pdf		
		

 Digitally signed with :iSign  
 Building And Construction Authority  
 12 Nov 24, 03:11 PM SGT

- ✓ **Digital fingerprint solution**  
More secure than traditional watermarks
- ✓ **Easy detection of changes**  
Small changes produce very different looking checksums
- ✓ **Files remain intact and can be viewed freely**  
Checksum solutions do not affect nor encrypt the files

Checksum of file embedded in QR Code:  
 158c66b52835a57a9a9924ede9634204e34  
 90b4197d39d40eb24a6bc05dd448b

### ► Advantages of the Checksum approach

As compared to the current approach where different agencies adopted different methods to demarcate Approved Plans, the checksum solution offers:



**Standardised approach**

- Can be used for all kinds of files, e.g. BIM and 2D files
- Can be used by all agencies to demarcate Approved Plans



**Ease of access and authentication**

- Files and plans can be viewed without decryption



**Quick verification of Approved Plans whenever in doubt**

- Less likelihood of forgery
- Verification can be done easily without special apps or on the internet

## Introduction of Checksums for Approved Plans

### ► How do I verify the authenticity of an Approved Plan through its Checksum?

To verify if a file is the Approved Plan, you can compare the checksum of the file with the checksum listed on the “List of Approved Plans”.

Verification with Netrust Digital Signer (NDS) [coming soon]

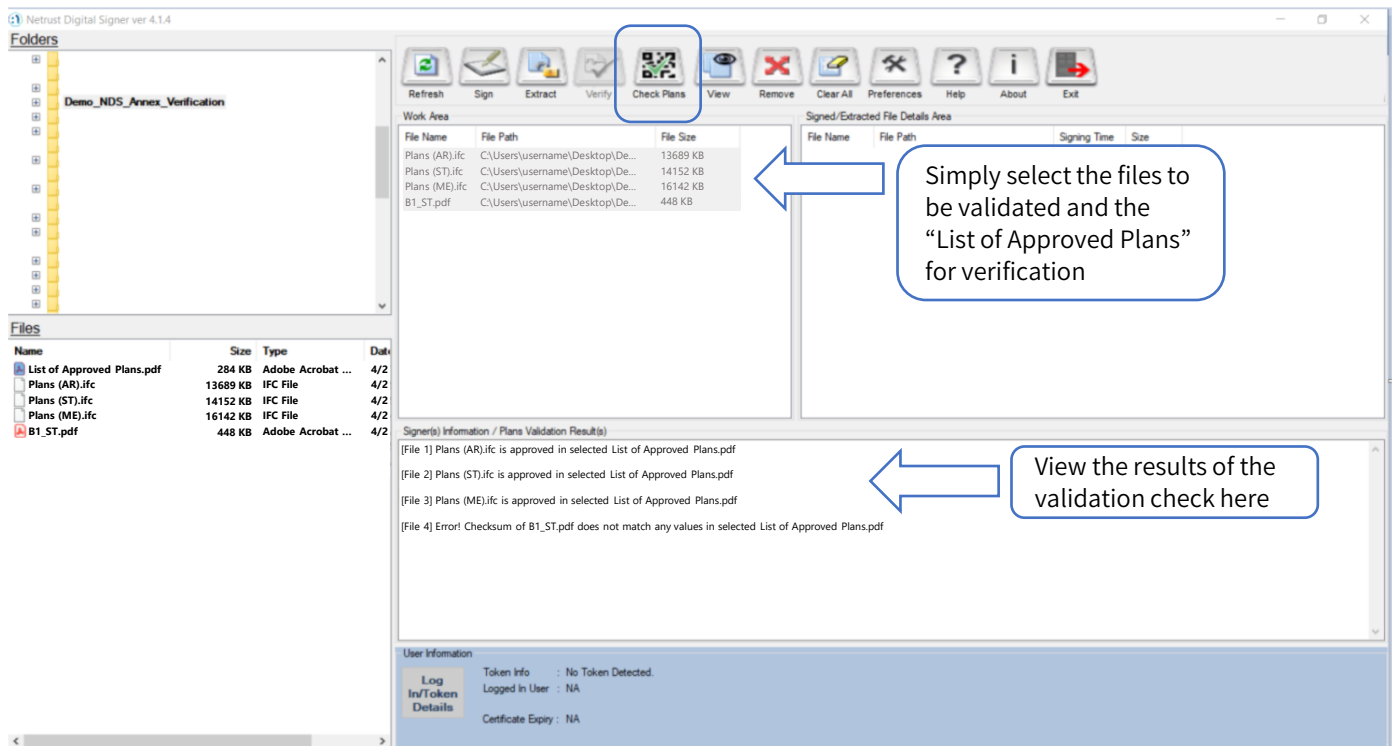





Verification without Netrust Digital Signer (NDS)

- Scan the QR code in the approval letter using any QR code reader to obtain the SHA256 checksum of the approved plan.
- Obtain the SHA256 checksum of the file you wish to verify. There are many ways to obtain the SHA256 checksum of the file (e.g. online tool at [https://emn178.github.io/online-tools/sha256\\_checksum.html](https://emn178.github.io/online-tools/sha256_checksum.html)).
- Compare the checksums from (a) and (b). The checksums will be the same if the file is the Approved Plan.



# SECTION 3

## Specific Requirements by: *Regulatory Agencies*

<b>3</b>	<b>Specific Requirements by</b>	<b>Page</b>
	 <b>Understanding the Table Format (for Section 3)</b>	27
	 <b>Regulatory Agencies</b>	
	• BCA	29
	• LTA	40
	• NEA	46
	• NParks	56
	• PUB	60
	• SCDF	63
	• URA	72
	 <b>Key Gateways</b>	
	Overview	85
	Glossary of Common Key Words	86
	- Pre-Submission, Planning and Other Consultations	89
	• G1 Design Gateway	96
	• G1.5 Piling Gateway (Optional)	113
	• G2 Construction Gateway	116
	- Independent Submissions	143
	• G3 Completion Gateway (TOP/CSC)	151
	 <b>Other Building Works</b>	
	• Overview of External Works	158
	○ LTA	160
	○ NParks	170
	○ PUB	173
	• Direct Submission Process (DSP)	177
	• Conservation	178
	• Part ST Submission	180
	• Infrastructure Works	185

# Understanding the Table Format

Note: CORENET X is developed through Agile Methodology and sections / requirements in this COP will be updated progressively and its technological enhancements will be made available in phases.

- Section, Main Header, Sub-Header
- Other COP Sections (Clickable Hyperlinks)
- Regulatory Agency Involved
- Legend (Archi, C&S, M&E, IFC Component)
- Requirements under the Key Gateways (corresponds to the Gateway No.)
  - G1: Design Gateway
  - G1.5: Piling Gateway
  - G2: Design Gateway
  - G3: Completion Gateway

Key Words appearing in a particular Gateway

Broad Description of requirements relating to the Key Word

+

IFC COMPONENT that may be required to be modelled for requirements under this keyword (linked to Section 4)

### Format of Submission

3D	IFC-SG Model
2D	Examples: CAD Drawings, Reports, Supporting Documents, Supplementary Documents

# Understanding the Table Format (Case Example)

Note: CORENET X is developed through Agile Methodology and sections / requirements in this COP will be updated progressively and its technological enhancements will be made available in phases.

I want to understand how to clear **BCA's** requirement for **Structural Design** under **Construction Gateway (G2)**

**1** Section 3: Specific Requirements by Regulatory Agencies  
**Building and Construction Authority (BCA)**

**2** G2 Construction Gateway (continued from previous page)

Key Words	Requirement Category	IFC COMPONENT
Structural Design	<b>Structural Design (Piling and Foundation Works)</b>	
Borehole, Pile, Slab, Column, Wall, etc.	<p><i>Can be provided at Piling Gateway (G1.5) or Construction Gateway (G2)</i></p> <ul style="list-style-type: none"> <li><b>Piling &amp; Foundation Works IFC-SG model</b></li> <li><b>Ground Investigation:</b> <ul style="list-style-type: none"> <li>Compliance with minimum number of borehole required as stipulated in Circular APPBCA-2016-08</li> </ul> </li> <li><b>2D Drawings limited to:</b> <ul style="list-style-type: none"> <li>General notes</li> <li>Irregular Pilecap / Footing Details</li> </ul> </li> <li><b>Design Calculation reports:</b> <ul style="list-style-type: none"> <li>From QP, AC, [QP(Geo) &amp; AC (Geo), if needed]</li> </ul> </li> <li><b>Additional Supporting Documents:</b> <ol style="list-style-type: none"> <li>Site investigation report in PDF &amp; AGS format</li> <li>Impact assessment report</li> <li>Topography</li> <li>Complete set of structural framing plan for reference</li> <li>Complete set of building plan for reference</li> <li>Completion letter of pre-consultation (for complex structure only)</li> </ol> </li> <li><b>Complete set of IFC-SG model(s)</b> for all structural elements &amp; details</li> <li><b>2D Drawings limited to:</b> <ul style="list-style-type: none"> <li>General notes</li> <li>Special details (e.g. slab reinforcement detailing, complex structure detailing, transfer plate detailing, irregular section detailing, precast joints, prestressed details, steel connections.)</li> </ul> </li> <li><b>Design Calculation reports:</b> <ul style="list-style-type: none"> <li>From QP, AC, [QP(Geo) &amp; AC (Geo), if needed]</li> </ul> </li> <li><b>Additional Supporting Documents:</b> <ol style="list-style-type: none"> <li>Site investigation report in PDF &amp; AGS format</li> <li>Impact assessment report</li> <li>Topography</li> <li>Complete set of building plan submitted simultaneously</li> <li>Completion letter of pre-consultation (for complex structure only)</li> </ol> </li> </ul>	8 IFC-Components tagged

**3** Find which \*discipline is responsible for compliance. In this case, it's C&S (green). If all disciplines are involved, all three colors will be tagged.

**4** Find out what are the broad requirements to comply and in what submission format. Note that QP is still required to refer to detailed codes & requirements in the appropriate docs (e.g. BC Act & Regulations)

**5** Find out what BIM Data Representation is required to be modelled for "Structural Design". In this case, there are 8 IFC-Components tagged.

For example, "Pile", "Column", "Wall". Look for these in Section 4.

**6** Click Hyperlink to navigate easily to Section 4: BIM Data Representation.

- 1** Go to Section 3: Specific Requirements Regulatory Agencies
- 2** Find which Gateway "Structural Design" falls under. In this case, it's required under Construction Gateway (G2).
- 3** Find which \*discipline is responsible for compliance. In this case, it's C&S (green). If all disciplines are involved, all three colors will be tagged.
- 4** Find out what are the broad requirements to comply and in what submission format. Note that QP is still required to refer to detailed codes & requirements in the appropriate docs (e.g. BC Act & Regulations)
- 5** Find out what BIM Data Representation is required to be modelled for "Structural Design". In this case, there are 8 IFC-Components tagged.
- 6** Click Hyperlink to navigate easily to Section 4: BIM Data Representation.

## ► Disclaimer

As disclaimed under Page 3, this Code of Practice does not substitute Handbooks, Circulars or other regulatory publications of our regulatory agencies. Readers should refer to the relevant Codes, Acts and Regulations on the compliance required for their projects, before referring to this Code of Practice on how to represent the compliance information in the CORENET X submission gateways

## ► Disciplines Color Tagging / QP's Responsibilities

\*As stated under Section 2: Page 15, the statutory responsibilities of the appointed QPs under the respective Acts and Regulations **remains unchanged. The color tagging is for reference only.**



# Building and Construction Authority (BCA)

Legend:  Architecture  C&S  M&E IFC COMPONENT

- Pre-Submission, Planning and Other Consultations		
	Key Words	Requirement Category
	Household / Storey Shelter (HS/SS)	<ul style="list-style-type: none"> <li>Pre-consultation on HS/SS shelter on architectural, structural or commissioning issues</li> <li>Can occur at any stage prior to TOP, for landed and non-landed residential projects</li> </ul>
	Public Transit Shelter (PS/TS)	<ul style="list-style-type: none"> <li>Pre-consultation on Public/Transit Shelter (PS/TS) on architectural, structural, M&amp;E or commissioning issues</li> <li>Can occur at any stage prior to TOP</li> </ul>
	Others	<p><b>Complex Building Requirements</b></p> <ul style="list-style-type: none"> <li>Pre-submission consultation of structural concept on structural works involving complex building to be carried out during/after Design Gateway (G1) but prior to Piling Gateway (G1.5) or Construction Gateway (G2)</li> </ul>

G1 Design Gateway		
	Key Words	Requirement Category
	Others	<p><b>Complex Building Requirements</b></p> <ul style="list-style-type: none"> <li>[For noting] Pre-submission consultation of structural concept on structural works involving complex building to be carried out concurrently with after Design Gateway (G1) but prior to Piling Gateway (G1.5) or Construction Gateway (G2)</li> </ul>

G1.5 Piling Gateway (Optional)		
	Key Words	Requirement Category
	Lightning Protection	<p><b>Note: These requirements are currently optional and will only be required for regulatory compliance when LPS plan submission is mandated</b></p> <ul style="list-style-type: none"> <li>For big projects adopting piles or raft foundation as natural earth-termination system. Provision of rebars for connection to the down-conductor system shall be provided during the piling stage.</li> </ul> <p><u>Notes:</u></p> <ul style="list-style-type: none"> <li>QP (Electrical) to provide inputs for submission by C&amp;S</li> <li>Developer or Builder is required to appoint a QP (Electrical) to supervise the LPS works before LPS Plan submission is carried out at the Construction Gateway (G2).</li> </ul>
	Structural Design	<p><b>Structural Design (Piling and Foundation Works)</b></p> <p><i>Can be provided at Piling Gateway (G1.5) or Construction Gateway (G2)</i>  <i>For large project meeting the criteria for part ST submissions, please refer to page 177 for more details</i></p> <ul style="list-style-type: none"> <li><b>Piling &amp; Foundation Works IFC-SG model</b></li> <li><b>Ground Investigation:</b> <ul style="list-style-type: none"> <li>Compliance with minimum number of borehole required as stipulated in Circular APPBCA-2016-08</li> </ul> </li> </ul>



# Building and Construction Authority (BCA)

Legend:  Architecture  C&S  M&E IFC COMPONENT

G1.5 Piling Gateway (Optional) <i>(continued from previous page)</i>	
Key Words	Requirement Category
<p>Structural Design</p> <div style="display: flex; flex-direction: column; gap: 5px;"> <div style="border: 1px solid gray; border-radius: 10px; padding: 2px 10px; text-align: center;">BEAM</div> <div style="border: 1px solid gray; border-radius: 10px; padding: 2px 10px; text-align: center;">BOREHOLE</div> <div style="border: 1px solid gray; border-radius: 10px; padding: 2px 10px; text-align: center;">FOOTING / PILECAP</div> <div style="border: 1px solid gray; border-radius: 10px; padding: 2px 10px; text-align: center;">PILE</div> <div style="border: 1px solid gray; border-radius: 10px; padding: 2px 10px; text-align: center;">SLAB</div> </div>	<p><b>Structural Design (Piling and Foundation Works) <i>(continued from previous page)</i></b></p> <ul style="list-style-type: none"> <li>• <b>2D Drawings limited to:</b> <ul style="list-style-type: none"> <li>○ General notes</li> <li>○ Irregular Pilecap / Footing Details</li> </ul> </li> </ul> <div style="display: flex; justify-content: space-between; margin-top: 10px;"> <div style="width: 45%;"> <p> <b>Design Calculation reports:</b></p> <ul style="list-style-type: none"> <li>• From QP, AC, [QP(Geo) &amp; AC (Geo), if needed]]</li> </ul> </div> <div style="width: 45%;"> <p> <b>Additional Supporting Documents:</b></p> <ol style="list-style-type: none"> <li>a) Site investigation report in PDF &amp; AGS format</li> <li>b) Impact assessment report</li> <li>c) Topography</li> <li>d) Complete set of structural framing plan for reference</li> <li>e) Complete set of building plan for reference</li> <li>f) Completion letter of pre-consultation (for complex structure only)</li> </ol> </div> </div>

G2 Construction Gateway	
Key Words	Requirement Category
<p>Access to Site</p> <div style="display: flex; flex-wrap: wrap; gap: 5px;"> <div style="border: 1px solid gray; border-radius: 10px; padding: 2px 10px; text-align: center; width: 45%;">ACCESSIBLE ROUTE</div> <div style="border: 1px solid gray; border-radius: 10px; padding: 2px 10px; text-align: center; width: 45%;">SLAB</div> <div style="border: 1px solid gray; border-radius: 10px; padding: 2px 10px; text-align: center; width: 45%;">RAMP</div> <div style="border: 1px solid gray; border-radius: 10px; padding: 2px 10px; text-align: center; width: 45%;">STAIRCASE</div> </div>	<ul style="list-style-type: none"> <li>• Passenger Alighting and Boarding Point</li> <li>• Accessible Route (to the development entrance)</li> </ul>
<p>Access within Building only</p> <div style="display: flex; flex-wrap: wrap; gap: 5px;"> <div style="border: 1px solid gray; border-radius: 10px; padding: 2px 10px; text-align: center; width: 45%;">ACCESSIBLE ROUTE</div> <div style="border: 1px solid gray; border-radius: 10px; padding: 2px 10px; text-align: center; width: 45%;">SLAB</div> <div style="border: 1px solid gray; border-radius: 10px; padding: 2px 10px; text-align: center; width: 45%;">RAMP</div> <div style="border: 1px solid gray; border-radius: 10px; padding: 2px 10px; text-align: center; width: 45%;">STAIRCASE</div> </div>	<ul style="list-style-type: none"> <li>• All Accessible Routes and associated clear Spaces (within the development)</li> <li>• Accessible and elder-friendly rooms</li> <li>• Seating and eating spaces for wheelchair users</li> <li>• Resting areas for the ambulant disabled</li> <li>• Location of hearing enhancement systems</li> </ul>
<p>Barrier</p> <div style="border: 1px solid gray; border-radius: 10px; padding: 2px 10px; text-align: center; width: 100%;">RAILING</div>	<ul style="list-style-type: none"> <li>• Safety from falling (ie. safety barrier height, size of any openings, kerb)</li> <li>• Protection from injury by vehicles in building (e.g. provision of bollards)</li> </ul>
<p>Buildability</p> <div style="display: flex; flex-wrap: wrap; gap: 5px;"> <div style="border: 1px solid gray; border-radius: 10px; padding: 2px 10px; text-align: center; width: 45%;">BEAM</div> <div style="border: 1px solid gray; border-radius: 10px; padding: 2px 10px; text-align: center; width: 45%;">SLAB</div> <div style="border: 1px solid gray; border-radius: 10px; padding: 2px 10px; text-align: center; width: 45%;">COLUMN</div> <div style="border: 1px solid gray; border-radius: 10px; padding: 2px 10px; text-align: center; width: 45%;">STAIRCASE</div> <div style="border: 1px solid gray; border-radius: 10px; padding: 2px 10px; text-align: center; width: 45%;">DOOR</div> <div style="border: 1px solid gray; border-radius: 10px; padding: 2px 10px; text-align: center; width: 45%;">WALL</div> <div style="border: 1px solid gray; border-radius: 10px; padding: 2px 10px; text-align: center; width: 45%;">HOUSEHOLD SHELTER</div> <div style="border: 1px solid gray; border-radius: 10px; padding: 2px 10px; text-align: center; width: 45%;">PREFAB &amp; MEP</div> </div>	<p><b>Buildability Design Implementation Plan (BDIP)</b></p> <ul style="list-style-type: none"> <li>• BIM model which describes and defines the type, extent of use and details of the Design for Manufacturing (DfMA) technologies, building systems, building components, buildable features, design standardisation across the Structural, Architectural and Mechanical, Electrical and Plumbing (MEP) systems</li> <li>• Where any of the above cannot be modelled in BIM, 2D plans can be submitted</li> </ul> <div style="margin-top: 10px;"> <p> <b>Buildable Design Score (B-Score)</b></p> <ol style="list-style-type: none"> <li>a) BS01 Form (in Excel format) to be submitted</li> </ol> </div>



# Building and Construction Authority (BCA)

Legend:  Architecture  C&S  M&E IFC COMPONENT

G2 Construction Gateway (continued from previous page)	
Key Words	Requirement Category
Building Envelope	<p><b>ETTV/RETV</b></p> <ul style="list-style-type: none"> <li>ETTV/RETV computation &amp; tabulation of design parameters in the prescribed forms &amp; formats;</li> <li>Architectural elevation drawings showing the composition of the different façade or wall systems that are relevant for the computation of the ETTV/RETV; and</li> <li>Architectural plan layouts &amp; elevations showing the mode of ventilation &amp; location for various spaces incl. air-conditioning areas.</li> </ul> <p><b>RTTV</b></p> <ul style="list-style-type: none"> <li>RTTV computation for roofs with skylight in prescribed forms and formats, where relevant;</li> <li>Architectural plan layout and sectional details of different roof types as well as the roof composition and respective U-values; and</li> <li>Technical material or product information and relevant calculation of U-value of the roof</li> </ul> <p>• <i>ETTV/RETV Calculation Format in respect of an Air-conditioned Building (BPD_BP04):</i>  <a href="https://www1.bca.gov.sg/docs/default-source/docs-corp-form/bp04.doc?sfvrsn=c3a0dcf4_2">https://www1.bca.gov.sg/docs/default-source/docs-corp-form/bp04.doc?sfvrsn=c3a0dcf4_2</a></p>
Dwelling Units	<ul style="list-style-type: none"> <li>Bathrooms for future retrofitting</li> <li>Design of unit entrance for wheelchair users</li> </ul>
Environmental Sustainability  <div style="display: flex; flex-wrap: wrap; gap: 10px;"> <div style="border: 1px solid #ccc; border-radius: 10px; padding: 2px 10px; background-color: #eee;">DOOR</div> <div style="border: 1px solid #ccc; border-radius: 10px; padding: 2px 10px; background-color: #eee;">SLAB</div> <div style="border: 1px solid #ccc; border-radius: 10px; padding: 2px 10px; background-color: #eee;">SPACE</div> <div style="border: 1px solid #ccc; border-radius: 10px; padding: 2px 10px; background-color: #eee;">WALL</div> <div style="border: 1px solid #ccc; border-radius: 10px; padding: 2px 10px; background-color: #eee;">WINDOW</div> <div style="border: 1px solid #ccc; border-radius: 10px; padding: 2px 10px; background-color: #eee;">CONTROL PANEL</div> </div>	<p><b>For Code for Environmental Sustainability of Buildings:</b></p> <p><u>To submit the following:</u></p> <ol style="list-style-type: none"> <li>i. BC ES Appendix 1 for <b>Construction Gateway</b> <a href="https://go.gov.sg/bc-es-app1">https://go.gov.sg/bc-es-app1</a></li> <li>ii. Documentary Evidence on Maintenance of Building Cooling System Performance (NRB06)</li> <li>iii. ACMV plan (for NRB06) drawing showing the requirement in BIM. Where any of the above cannot be modelled in BIM, 2D plans can be submitted.</li> </ol> <p>Guidance Notes and Documentation Requirements under Code for Environmental Sustainability of Buildings: <a href="https://www1.bca.gov.sg/buildsg/sustainability/regulatory-requirements-for-new-buildings-existing-buildings-undergoing-major-aanda">https://www1.bca.gov.sg/buildsg/sustainability/regulatory-requirements-for-new-buildings-existing-buildings-undergoing-major-aanda</a></p> <p><b>For Government Land Sales (GLS) programme requirement:</b>                      please refer to the following link: <a href="https://www1.bca.gov.sg/buildsg/sustainability/regulatory-requirements-for-new-buildings-existing-buildings-undergoing-major-aanda/mandatory-higher-green-mark-standard">https://www1.bca.gov.sg/buildsg/sustainability/regulatory-requirements-for-new-buildings-existing-buildings-undergoing-major-aanda/mandatory-higher-green-mark-standard</a></p>
Headroom and Ceiling height	<ul style="list-style-type: none"> <li>Headroom of every room, access route and circulation areas</li> <li>Ceiling height of rooms and spaces</li> </ul>
Household / Storey Shelter (HS/SS)	<p><b>Architecture</b></p> <p>Compliance with technical requirements on HS/SS position, area, volume, setback requirements, SS compartmentalization, HS/SS wall requirements, HS/SS door and SS blast hatch requirements, shielding wall requirements, HS/SS ventilation sleeve requirements, NS requirements, voids within HS/SS setback distance, downhang beam and trellis requirements, service risers &amp; gas risers &amp; refuse chute requirements, electrical power sockets outlets, telephony outlets and lighting points. Where any of the above cannot be modelled in BIM, 2D plans can be submitted</p> <p><b>C&amp;S</b></p> <ul style="list-style-type: none"> <li>Compliance to structural requirements stipulated in technical requirements on household shelters and storey shelters. Where any of the above cannot be modelled in BIM, 2D plans can be submitted</li> </ul> <p><b>Supporting Documents:</b></p> <ol style="list-style-type: none"> <li>a) Submit HS/SS Shock Calculations as supplementary non-BIM documentation</li> </ol>



# Building and Construction Authority (BCA)

Legend:  Architecture  C&S  M&E IFC COMPONENT

G2 Construction Gateway <i>(continued from previous page)</i>					
Key Words	Requirement Category				
Lift and Escalators	<ul style="list-style-type: none"> <li>Lift and Escalator Provision (Number)</li> <li>Location of passenger and Accessible Lifts (including platform and stair lifts)</li> <li><b>2D Drawings limited to:</b> <ul style="list-style-type: none"> <li>Buttons, Handrail, Marking of Maneuvring Space</li> </ul> </li> </ul>				
Lightning Protection	<p><b>Note: These requirements are currently optional and will only be required for regulatory compliance when LPS plan submission is mandated</b></p> <p><b>2D Drawings</b></p> <ul style="list-style-type: none"> <li>Location of air-termination system, down conductors, earth electrodes</li> <li>Zone of lightning protection provided by the air-termination network for open roof spaces and the sides of the building</li> <li>Location of the points where there is equipotential bonding between the air-termination system, down-conductor system and earthed termination system; and</li> <li>Location of the points where there is equipotential bonding of the lightning protection system to electrically conductive parts of the building except M&amp;E services.</li> </ul> <p><b>Supporting Documents:</b></p> <ol style="list-style-type: none"> <li>Material specification, photo, ppt, excel, words, etc. should be submitted</li> </ol>				
Materials	<ul style="list-style-type: none"> <li>Use of Glass at height</li> <li>Daylight Reflectance</li> </ul>				
Public/Transit Shelter (PS/TS)	<table border="1" style="width: 100%; border-collapse: collapse;"> <thead> <tr> <th style="background-color: #eee; width: 50%;"><b>Building Plan (Architecture)</b></th> <th style="background-color: #eee; width: 50%;"><b>Structural Plan (C&amp;S)</b></th> </tr> </thead> <tbody> <tr> <td style="vertical-align: top;"> <p>The following shall be clearly illustrated in the submission:</p> <ul style="list-style-type: none"> <li>Entrance area layout leading from opening at ground level (or elsewhere) to the EHD and PT door, including firemen staircases and exit routes.</li> <li>Strike point lines and distance measured between strike points and the EHD/PT doors.</li> <li>All wall and slab thickness</li> <li>All air shafts and bomb pit layouts with dimensions, from opening at ground (or elsewhere) to the plantroom interface.</li> <li>Location and demarcation of all dry toilet areas, net areas occupied by each cluster of dry toilets, cubicles, floor trap etc.</li> <li>Demarcate net shelter area at each level, indicate the calculated areas and shelter size category in the plans.</li> <li>Blast, blast and gas, and gas protected walls and slabs shall be highlighted with differentiated hatching and/or colours in a consistent manner.</li> </ul> </td> <td style="vertical-align: top;"> <p>The following shall be clearly illustrated in the submission:</p> <ul style="list-style-type: none"> <li>Entrance area layout leading from opening at ground level (or elsewhere) to the EHD and PT door, including firemen staircases and exit routes.</li> <li>Strike point lines and distance measured between strike points and the EHD/PT doors.</li> <li>Line load design and reinforcement details for support structures of CD doors.</li> <li>All RC wall and slab thicknesses</li> </ul> </td> </tr> </tbody> </table>	<b>Building Plan (Architecture)</b>	<b>Structural Plan (C&amp;S)</b>	<p>The following shall be clearly illustrated in the submission:</p> <ul style="list-style-type: none"> <li>Entrance area layout leading from opening at ground level (or elsewhere) to the EHD and PT door, including firemen staircases and exit routes.</li> <li>Strike point lines and distance measured between strike points and the EHD/PT doors.</li> <li>All wall and slab thickness</li> <li>All air shafts and bomb pit layouts with dimensions, from opening at ground (or elsewhere) to the plantroom interface.</li> <li>Location and demarcation of all dry toilet areas, net areas occupied by each cluster of dry toilets, cubicles, floor trap etc.</li> <li>Demarcate net shelter area at each level, indicate the calculated areas and shelter size category in the plans.</li> <li>Blast, blast and gas, and gas protected walls and slabs shall be highlighted with differentiated hatching and/or colours in a consistent manner.</li> </ul>	<p>The following shall be clearly illustrated in the submission:</p> <ul style="list-style-type: none"> <li>Entrance area layout leading from opening at ground level (or elsewhere) to the EHD and PT door, including firemen staircases and exit routes.</li> <li>Strike point lines and distance measured between strike points and the EHD/PT doors.</li> <li>Line load design and reinforcement details for support structures of CD doors.</li> <li>All RC wall and slab thicknesses</li> </ul>
<b>Building Plan (Architecture)</b>	<b>Structural Plan (C&amp;S)</b>				
<p>The following shall be clearly illustrated in the submission:</p> <ul style="list-style-type: none"> <li>Entrance area layout leading from opening at ground level (or elsewhere) to the EHD and PT door, including firemen staircases and exit routes.</li> <li>Strike point lines and distance measured between strike points and the EHD/PT doors.</li> <li>All wall and slab thickness</li> <li>All air shafts and bomb pit layouts with dimensions, from opening at ground (or elsewhere) to the plantroom interface.</li> <li>Location and demarcation of all dry toilet areas, net areas occupied by each cluster of dry toilets, cubicles, floor trap etc.</li> <li>Demarcate net shelter area at each level, indicate the calculated areas and shelter size category in the plans.</li> <li>Blast, blast and gas, and gas protected walls and slabs shall be highlighted with differentiated hatching and/or colours in a consistent manner.</li> </ul>	<p>The following shall be clearly illustrated in the submission:</p> <ul style="list-style-type: none"> <li>Entrance area layout leading from opening at ground level (or elsewhere) to the EHD and PT door, including firemen staircases and exit routes.</li> <li>Strike point lines and distance measured between strike points and the EHD/PT doors.</li> <li>Line load design and reinforcement details for support structures of CD doors.</li> <li>All RC wall and slab thicknesses</li> </ul>				





# Building and Construction Authority (BCA)

Legend:



Architecture



C&S



M&E

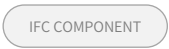

G2 Construction Gateway <i>(continued from previous page)</i>	
Key Words	Requirement Category
<p>Staircase</p> <p>STAIRCASE RAILING</p>	<ul style="list-style-type: none"> <li>Minimum Width</li> <li>Tread and Riser, Handrail / Railin</li> </ul>
<p>Statistical Gross Floor Area (SGFA)</p> <p>SGFA refers to the total floor area of a building, regardless of the usage of the space.</p> <p>Details of SGFA computation can be found in the SGFA Form BCA-BP-SGFA. The updated SGFA Form can be downloaded at <a href="https://go.gov.sg/sgfa">https://go.gov.sg/sgfa</a>.</p>	<ul style="list-style-type: none"> <li>Provision of General Building SGFA for below and above sublevels.</li> <li>Provision of Specified Building SGFA for below and above sublevels.</li> <li>Form BCA-BP-SGFA</li> </ul> <p><b>Additional Supporting Documents:</b> Where any of the above SGFA cannot be modelled in BIM, 2D SGFA plans can be submitted :</p> <p><b>Site Plan</b> – SGFA Table with information on SGFA for General Building and Specified Building at below sublevel and above sublevel. For amendment plan, SGFA Table should include SGFA (Approved), Changes (+/-) and SGFA (Proposed).</p> <p><b>Floor Plan</b> – To indicate General and Specified Building SGFA at below sublevel and above sublevel.</p>
<p>Structural Design</p> <p>BOREHOLE PILE</p> <p>FOOTING / PILECAP SLAB</p> <p>BEAM COLUMN</p> <p>STAIRCASE WALL</p>	<p><b>Structural Design (Piling and Foundation Works)</b></p> <p><i>Can be provided at Piling Gateway (G1.5) or Construction Gateway (G2)</i>  <i>For large project meeting the criteria for part ST submissions, please refer <a href="#">here</a> for more details</i></p> <ul style="list-style-type: none"> <li><b>Piling &amp; Foundation Works IFC-SG model</b></li> <li><b>Ground Investigation:</b> <ul style="list-style-type: none"> <li>Compliance with minimum number of borehole required as stipulated in Circular APPBCA-2016-08</li> </ul> </li> <li><b>2D Drawings limited to:</b> <ul style="list-style-type: none"> <li>General notes</li> <li>Irregular Pilecap / Footing Details</li> </ul> </li> <li><b>Design Calculation Reports:</b> <ul style="list-style-type: none"> <li>From QP, AC, [QP(Geo) &amp; AC (Geo), if needed]</li> </ul> </li> </ul> <p><b>Additional Supporting Documents:</b></p> <ol style="list-style-type: none"> <li>Site investigation report in PDF &amp; AGS format</li> <li>Impact assessment report</li> <li>Topography</li> <li>Complete set of structural framing plan for reference</li> <li>Complete set of building plan for reference</li> <li>Completion letter of pre-consultation (for complex structure only)</li> </ol>
	<ul style="list-style-type: none"> <li><b>Complete set of IFC-SG model(s)</b> for all Structural Elements &amp; Details</li> <li><b>2D Drawings limited to:</b> <ul style="list-style-type: none"> <li>General notes</li> <li>Special details (e.g. slab reinforcement detailing, complex structure detailing, transfer plate detailing, irregular section detailing, precast joints, prestressed details, steel connections.)</li> </ul> </li> </ul>



# Building and Construction Authority (BCA)

Legend:  Architecture  C&S  M&E IFC COMPONENT

G2 Construction Gateway <i>(continued from previous page)</i>	
Key Words	Requirement Category
Structural Design	<ul style="list-style-type: none"> <li>• <b>2D Drawings limited to</b> <i>(continued from previous page)</i></li> </ul> <p><b>Design Calculation Reports:</b></p> <ul style="list-style-type: none"> <li>• From QP, AC, [QP(Geo) &amp; AC (Geo), if needed]</li> </ul> <p><b>Additional Supporting Documents:</b></p> <ol style="list-style-type: none"> <li>Site investigation report in PDF &amp; AGS format</li> <li>Impact assessment report</li> <li>Topography</li> <li>Complete set of building plan submitted simultaneously</li> <li>Completion letter of pre-consultation (for complex structure only)</li> </ol>
Vehicular Parking <div style="display: flex; justify-content: space-around; margin-top: 5px;"> <div style="border: 1px solid gray; border-radius: 10px; padding: 2px 5px; background-color: #f2f2f2;">PARKING LOT</div> <div style="border: 1px solid gray; border-radius: 10px; padding: 2px 5px; background-color: #f2f2f2;">ACCESSIBLE ROUTE</div> </div>	<ul style="list-style-type: none"> <li>• Provision of Accessible and Family Lot(s)</li> </ul>
Ventilation <div style="display: flex; justify-content: space-around; margin-top: 5px;"> <div style="border: 1px solid gray; border-radius: 10px; padding: 2px 5px; background-color: #f2f2f2;">SPACE</div> <div style="border: 1px solid gray; border-radius: 10px; padding: 2px 5px; background-color: #f2f2f2;">PARKING LOT</div> </div> <div style="display: flex; justify-content: space-around; margin-top: 5px;"> <div style="border: 1px solid gray; border-radius: 10px; padding: 2px 5px; background-color: #f2f2f2;">WINDOW</div> </div>	<ul style="list-style-type: none"> <li>• Provision of Ventilation (Natural Ventilation for residential development)</li> <li>• Minimum 5% opening for Natural Ventilation</li> <li>• Maximum distance (12m) from Natural Ventilating opening</li> <li>• Natural Ventilation (dimension of recess / airwell)</li> <li>• Carpark Ventilation</li> </ul>
Washroom <div style="display: flex; justify-content: space-around; margin-top: 5px;"> <div style="border: 1px solid gray; border-radius: 10px; padding: 2px 5px; background-color: #f2f2f2;">SPACE</div> <div style="border: 1px solid gray; border-radius: 10px; padding: 2px 5px; background-color: #f2f2f2;">SANITARY APPLIANCES</div> </div> <div style="display: flex; justify-content: space-around; margin-top: 5px;"> <div style="border: 1px solid gray; border-radius: 10px; padding: 2px 5px; background-color: #f2f2f2;">CUBICLE</div> </div>	<ul style="list-style-type: none"> <li>• Sanitary provisions for wheelchair users (including accessible changing rooms) and ambulant disabled</li> <li>• Sanitary provisions for young children</li> </ul>

- Independent Submissions	
Key Words	Requirement Category
Constructability	<p><b><u>Constructability Implementation Plan (CIP)</u></b></p> <ul style="list-style-type: none"> <li>• BIM Plans which describe and define the type, extent of use and details of the system framework</li> <li>• Where any of the above cannot be modelled in BIM, 2D plans can be submitted</li> </ul> <p> <b>Supporting Documents for CIP:</b></p> <ol style="list-style-type: none"> <li>Documents (e.g. photos, 2D plans, etc.) on the use of construction techniques, processes, plant, equipment and innovative methods</li> </ol> <p> <b>Constructability Score (C-Score)</b></p> <ol style="list-style-type: none"> <li>C-Score Calculations (to be computed and submitted by Builder in PDF format)</li> </ol>
Environmental Sustainability	<p><b><u>Major Energy Use Change during Operation</u></b></p> <ul style="list-style-type: none"> <li>• Design and As-built clearance for major energy use change.</li> <li>• For more information, please refer to Code on Environmental Sustainability Measures for Existing Building: <a href="https://www1.bca.gov.sg/buildsg/sustainability/regulatory-requirements-for-existing-buildings">https://www1.bca.gov.sg/buildsg/sustainability/regulatory-requirements-for-existing-buildings</a></li> </ul>



# Building and Construction Authority (BCA)

Legend:  Architecture  C&S  M&E  Builder IFC COMPONENT

- Independent Submissions	
Key Words	Requirement Category
Environmental Sustainability <i>(continued from previous page)</i>	<p><b><u>Periodic Energy Audit during Operation</u></b></p> <ul style="list-style-type: none"> <li>Submission of Periodic Energy Audit</li> <li>For more information, please refer to: <a href="https://www1.bca.gov.sg/buildsg/sustainability/regulatory-requirements-for-existing-buildings/mandatory-submission-of-periodic-energy-audits">https://www1.bca.gov.sg/buildsg/sustainability/regulatory-requirements-for-existing-buildings/mandatory-submission-of-periodic-energy-audits</a></li> </ul>
Public Transit Shelter (PS/TS)	<ul style="list-style-type: none"> <li><b><u>Detailed CD Door and Services Penetration</u></b></li> </ul> <p>The following shall be clearly illustrated in the submission:</p> <ul style="list-style-type: none"> <li>- EHD and PT door details - All CD door leaf and door frame details including frame anchorages and associated reinforcement. CD support structures and their line load reinforcement details, including any adjacent services penetrations.</li> <li>- Services penetrations - Size of openings and type of services penetrations such as MCTs, puddle flanges etc in walls or slabs next to or in the vicinity of the CD doors.</li> </ul>
	<ul style="list-style-type: none"> <li><b><u>Mechanical Plans (CM)</u></b> <ul style="list-style-type: none"> <li><b>Environmental Control System (ECS), Water Supply System, Sanitary System, Drainage System, Fire Protection System</b></li> </ul> </li> </ul> <p>The following shall be clearly illustrated in the submission for each of the systems above:</p> <ul style="list-style-type: none"> <li>- All CD related plantrooms and ancillary rooms, locations, setting-out and performance capacities of CD related equipment, services sizes, layout and routings and their supports</li> <li>- CD permanent toilets and CD dry toilets</li> <li>- All CD related schematics, single line diagrams and typical installation details</li> <li>- Locations, clear dimensions and performance capacities of CD related equipment, accessories, services and their supports from ceilings, walls and floors</li> <li>- Size of openings and type of services penetrations such as MCTs, puddle flanges etc in walls or slabs next to or in the vicinity of the CD doors</li> </ul> <p>Provision of ventilation duct hinged-end doors (VDHD) at all ventilation supply and exhaust openings at the ventilation shafts/plenums</p>
	<ul style="list-style-type: none"> <li><b><u>Electrical Plan (CE)</u></b> <ul style="list-style-type: none"> <li><b>Electrical Power System, CD Communications System, CD Door Monitoring System, CD Equipment Monitoring System</b></li> </ul> </li> </ul> <p>The following shall be clearly illustrated in the submission for each of the systems above:</p> <ul style="list-style-type: none"> <li>- CD Plans layout at ground level, station concourse, station platform and any other level or space associated with the CD shelter, such as mezzanine floors and subway connections</li> <li>- All CD related plantrooms and ancillary rooms, setting-out and performance capacities of CD related equipment, accessories and services sizes, layout, and routings and their related supports</li> <li>- All CD related single line diagrams, schematics and typical installation details</li> <li>- Locations, clear dimensions and performance capacities of CD related equipment, accessories, services and their supports from ceilings, walls and floors</li> <li>- Size of openings and type of services penetrations such as MCTs, puddle flanges etc in walls or slabs next to or in the vicinity of the CD doors</li> </ul>



# Building and Construction Authority (BCA)

Legend:  Architecture  C&S  M&E  Builder IFC COMPONENT

Independent Submissions	
Key Words	Requirement Category
<div style="display: flex; flex-direction: column; align-items: center;"> <div style="width: 100%; height: 40px; background-color: orange;"></div> <div style="width: 100%; height: 40px; background-color: green;"></div> <div style="width: 100%; height: 40px; background-color: yellow;"></div> </div> <p>Public Transit Shelter (PS/TS)  <i>(continued from previous page)</i></p>	<ul style="list-style-type: none"> <li>• <b><u>Shock Design</u></b></li> </ul> <p>Shock Design for Architectural &amp; Structural (CKS), Mechanical (CKM) and Electrical (CKE) works shall be submitted with the following:</p> <ol style="list-style-type: none"> <li>1. Cover letter</li> <li>2. Shock design report</li> <li>3. Shock calculations for equipment</li> <li>4. Shock calculations for services</li> <li>5. Detailed drawings for shock support</li> </ol>
<div style="display: flex; flex-direction: column; align-items: center;"> <div style="width: 100%; height: 240px; background-color: green;"></div> </div> <p>Structural Design</p>	<p><b><u>Structural Design (Other Works e.g. demolition, ERSS, cladding, safety barrier, temporary traffic decking)</u></b></p> <ul style="list-style-type: none"> <li>• <b>2D Drawings are acceptable</b> for independent submissions.</li> <li>• Structural design of ancillary works and component such as demolition, temporary ERSS, barriers &amp; cladding, temporary traffic decking</li> <li>• Structural design of localized works for ancillary structures e.g. cladding, barrier</li> <li>• These plans will need to make reference back to the coordinated model submitted by the Main QP at the Construction Gateway (G2).</li> </ul> <p> <b><u>Design Calculation Reports</u></b></p> <ul style="list-style-type: none"> <li>• From QP, AC, [QP(Geo) &amp; AC (Geo), if needed]]</li> </ul> <p> <b><u>Additional Supporting Documents:</u></b></p> <ol style="list-style-type: none"> <li>a) Site investigation report in pdf &amp; AGS format</li> <li>b) Impact assessment report</li> <li>c) Design consideration for Earth Retaining or Stabilising Structures (ERSS)) – ERSS_Annex A</li> <li>d) QP’s &amp; AC’s Certification for fixings of ancillary structures</li> </ol>



# Building and Construction Authority (BCA)

Legend:  Architecture  C&S  M&E  Builder IFC COMPONENT

G3 Completion Gateway	
Key Words	Requirement Category
Buildability Score (B-Score) & Constructability Score (C-Score)	<p><b><u>Buildability Design Implementation Plan (BDIP)</u></b></p> <ul style="list-style-type: none"> <li>BIM model which describes and defines the type, extent of use and details of the Design for Manufacturing (DfMA) technologies, building systems, building components, buildable features, design standardisation across the Structural, Architectural and Mechanical, Electrical and Plumbing (MEP) systems</li> <li>Where any of the above cannot be modelled in BIM, 2D plans can be submitted</li> </ul> <p> <b><u>Buildable Design Score (B-Score)</u></b></p> <p>a) BS03 Form (in Excel format) to be submitted</p> <hr/> <p><b><u>Constructability Implementation Plan (CIP)</u></b></p> <ul style="list-style-type: none"> <li>BIM Plans which describe and define the type, extent of use and details of the system framework</li> <li>Where any of the above cannot be modelled in BIM, 2D plans can be submitted</li> </ul> <p> <b><u>Supporting Documents for CIP:</u></b></p> <p>a) Documents (e.g. photos, 2D plans, etc.) on the use of construction techniques, processes, plant, equipment and innovative methods</p> <p> <b><u>Constructability Score (C-Score)</u></b></p> <p>a) C-Score Calculations (to be computed and submitted by Builder in PDF format)</p>
Civil Defence Shelter (Non-Transit/Non-Public)	<ul style="list-style-type: none"> <li>Inspection of Civil Defence Shelter (Non-Transit/Non-Public)</li> <li>Checklist for submission with Inspection of Civil Defence Shelter (Non-Transit/Non-Public)</li> </ul>
Completion of Structural Works	<ul style="list-style-type: none"> <li>Submission Certificate of Record Structural Plans/Calculations</li> <li>Certificate of Supervision of Piling/Structural Works</li> <li>Certificate of Supervision of Geotechnical Building Works</li> <li>Accredited Checker's Endorsement of Record Structural Plans/Calculation</li> <li>Specialist Accredited Checker's Endorsement of Record Geotechnical Building Works Plans/Calculation</li> <li>Builder certificate of completion of the Building Works</li> </ul>
Environmental Sustainability	<p><b>For Code for Environmental Sustainability of Buildings:</b></p> <p><u>To submit the following:</u></p> <ol style="list-style-type: none"> <li>BC ES Appendix 1 for <b>Completion Gateway</b> <a href="https://go.gov.sg/bc-es-app1">https://go.gov.sg/bc-es-app1</a></li> <li>Documentary Evidence based on the Guidance Notes and Documentation Requirements under Code for Environmental Sustainability of Buildings: <a href="https://www1.bca.gov.sg/buildsg/sustainability/regulatory-requirements-for-new-buildings-existing-buildings-undergoing-major-aanda">https://www1.bca.gov.sg/buildsg/sustainability/regulatory-requirements-for-new-buildings-existing-buildings-undergoing-major-aanda</a></li> </ol> <p><b>For Government Land Sales (GLS) programme requirement:</b></p> <p>Please refer to the following link: <a href="https://www1.bca.gov.sg/buildsg/sustainability/regulatory-requirements-for-new-buildings-existing-buildings-undergoing-major-aanda/mandatory-higher-green-mark-standard">https://www1.bca.gov.sg/buildsg/sustainability/regulatory-requirements-for-new-buildings-existing-buildings-undergoing-major-aanda/mandatory-higher-green-mark-standard</a></p>



# Building and Construction Authority (BCA)

Legend:  Architecture  C&S  M&E  Builder IFC COMPONENT

G3 Completion Gateway					
Key Words	Requirement Category				
Public/Transit Shelter (PS/TS) Technical Clearances	<p><b>Method statement for commissioning tests (CT)</b></p> <ol style="list-style-type: none"> <li>Internal overpressure test (IOPT)</li> <li>Overpressure regime and airflow test (ORAT)</li> <li>Integration system test (IST)</li> </ol>				
	<p><b>Commissioning test report (CT)</b></p> <ol style="list-style-type: none"> <li>Internal overpressure test (IOPT)</li> <li>Overpressure regime and airflow test (ORAT)</li> <li>Integration system test (IST)</li> </ol>				
	<p><b>Notice of Approval of Commissioning (NOAC) (CN)</b></p> <table border="0" style="width: 100%; border-collapse: collapse;"> <tr> <td style="width: 20%; border-right: 1px solid #ccc; vertical-align: top;">                             1. CD NOA letters of As-built plans for:                             <ul style="list-style-type: none"> <li>• Architectural</li> <li>• Structural</li> <li>• ECS</li> <li>• FPS</li> <li>• Water Services</li> <li>• Sanitary</li> <li>• Drainage</li> <li>• Electrical</li> <li>• CD Communications</li> <li>• CD EMS System</li> <li>• CD Door Monitoring System</li> <li>• CD MATV</li> </ul> </td> <td style="width: 20%; border-right: 1px solid #ccc; vertical-align: top;">                             2. CD Certificate of Supervision (COS) letters for:                             <ul style="list-style-type: none"> <li>• CD Related Architectural Works</li> <li>• CD Related Structural Works, MCTs, CD Valves, CD Doors</li> <li>• CD Electrical System</li> <li>• CD Door Monitoring System</li> <li>• CD Equipment Monitoring System</li> <li>• CD Communications System</li> <li>• CD Environment Control System &amp; Fire Protection Systems</li> <li>• CD WSSDS</li> </ul> </td> <td style="width: 20%; border-right: 1px solid #ccc; vertical-align: top;">                             3. CD NOA letters for IOPT, ORAT and CDIST reports                         </td> <td style="width: 20%; border-right: 1px solid #ccc; vertical-align: top;">                             4. CD NOA letters with summary table for all shock design submissions                         </td> <td style="width: 20%; vertical-align: top;">                             5. CD NOAC Inspection Report with rectified defects list containing clear before and after colour photos and description of remedial actions taken.                         </td> </tr> </table>	1. CD NOA letters of As-built plans for: <ul style="list-style-type: none"> <li>• Architectural</li> <li>• Structural</li> <li>• ECS</li> <li>• FPS</li> <li>• Water Services</li> <li>• Sanitary</li> <li>• Drainage</li> <li>• Electrical</li> <li>• CD Communications</li> <li>• CD EMS System</li> <li>• CD Door Monitoring System</li> <li>• CD MATV</li> </ul>	2. CD Certificate of Supervision (COS) letters for: <ul style="list-style-type: none"> <li>• CD Related Architectural Works</li> <li>• CD Related Structural Works, MCTs, CD Valves, CD Doors</li> <li>• CD Electrical System</li> <li>• CD Door Monitoring System</li> <li>• CD Equipment Monitoring System</li> <li>• CD Communications System</li> <li>• CD Environment Control System &amp; Fire Protection Systems</li> <li>• CD WSSDS</li> </ul>	3. CD NOA letters for IOPT, ORAT and CDIST reports	4. CD NOA letters with summary table for all shock design submissions
1. CD NOA letters of As-built plans for: <ul style="list-style-type: none"> <li>• Architectural</li> <li>• Structural</li> <li>• ECS</li> <li>• FPS</li> <li>• Water Services</li> <li>• Sanitary</li> <li>• Drainage</li> <li>• Electrical</li> <li>• CD Communications</li> <li>• CD EMS System</li> <li>• CD Door Monitoring System</li> <li>• CD MATV</li> </ul>	2. CD Certificate of Supervision (COS) letters for: <ul style="list-style-type: none"> <li>• CD Related Architectural Works</li> <li>• CD Related Structural Works, MCTs, CD Valves, CD Doors</li> <li>• CD Electrical System</li> <li>• CD Door Monitoring System</li> <li>• CD Equipment Monitoring System</li> <li>• CD Communications System</li> <li>• CD Environment Control System &amp; Fire Protection Systems</li> <li>• CD WSSDS</li> </ul>	3. CD NOA letters for IOPT, ORAT and CDIST reports	4. CD NOA letters with summary table for all shock design submissions	5. CD NOAC Inspection Report with rectified defects list containing clear before and after colour photos and description of remedial actions taken.	
Record Building Plans	<ul style="list-style-type: none"> <li>• Record Plans</li> </ul>				



# Building and Construction Authority (BCA)

Legend:



Architecture



C&S



M&E



Builder

IFC COMPONENT

G3 Completion Gateway	
Key Words	Requirement Category
Technical Clearance (TOP/CSC)	<ul style="list-style-type: none"> <li>Universal Design Index FormSG Acknowledgement</li> <li>CONQUAS / QM</li> </ul>
	<ul style="list-style-type: none"> <li>Site Inspection Report/Checklist</li> <li>Phasing Plan</li> <li>Clearance for Environmental Sustainability</li> <li>Clearance for Buildability and Constructability</li> </ul>
	<ul style="list-style-type: none"> <li>Annex A Safety Barrier</li> <li>Annex A Engineered Façade</li> </ul>
	<ul style="list-style-type: none"> <li>Certificate of Supervision for Lightning Protection System (LPS)</li> <li>Permit to Operate (Lift &amp; Escalator)</li> <li>Certificate of Supervision for Air-Conditioning and Mechanical Ventilation System(s)</li> </ul>
	<ul style="list-style-type: none"> <li>Builder's Certificate (for building works without any structural works)</li> </ul>

----- **End of Requirements for BCA** -----



# Land Transport Authority (LTA)

Legend:



Architecture





C&S

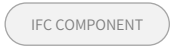

M&E



IFC COMPONENT

- Pre-Submission, Planning and Other Consultations	
Key Words	Requirement Category
Impact Studies only	<p> <b>Transport Impact Assessment (TIA)</b></p> <ul style="list-style-type: none"> <li>• Generally, a TIA submission is required if the type and size of the proposed development meets one or more of the criteria stipulated in LTA's guidelines.</li> <li>• The traffic consultant shall arrange scoping meeting with LTA to discuss the scope of study, TIA classifications and confirm if Walking and Cycling Plan (WCP) is required.</li> <li>• The TIA report is to be set out logically with clear analyses, conclusions and recommendations. All assumptions and sources of information are to be clearly documented. Executive Summary shall be included to provide concise and clear information on the study purpose, major findings, conclusions and recommendations. Improvements recommended in the TIA are to be illustrated using appropriate plan(s) with sufficient detail to substantiate their feasibility. All the analysis files and data related to the study are to be submitted as appendices to the Report for LTA's records.</li> <li>• All recommended improvement works to be carried out by the developer shall be incorporated in the development plan submissions at Design Gateway (G1) and Construction Gateway (G2) to LTA for clearance.</li> </ul> <p><i>Note: LTA is currently reviewing the submission process for TIA.</i></p>
	<p> <b>Pre-Application Feasibility Study &amp; Recommendations</b></p> <ul style="list-style-type: none"> <li>• LTA should be consulted to confirm whether a PAFS is needed for the proposed residential site if they are undergoing redevelopment arising from a collective or en-bloc sales.</li> <li>• The traffic consultant shall arrange scoping meeting with LTA to discuss the scope of study</li> <li>• PAFS should assess the traffic impact on the area and propose car-lite measures/initiatives, traffic demand management measures and/or feasible transport improvement plans to support the redevelopment proposal.</li> <li>• All recommended improvement works to be carried out by the developer shall be incorporated in the development plan submissions at Design Gateway (G1) and Construction Gateway (G2) to LTA for clearance</li> </ul>
	<p> <b>Walking and Cycling Plan (WCP)</b></p> <ul style="list-style-type: none"> <li>• The rigorous process of the WCP shall be demonstrated and presented in a written report that explains the rationale for the following 5 sets of plans:                             <ol style="list-style-type: none"> <li>1. Location and Connectivity Plan</li> <li>2. Circulation Plan</li> <li>3. Conflict Mitigating Plan</li> <li>4. Bicycle Parking and End of Trip Facility Plan</li> <li>5. Wayfinding Plan</li> </ol> </li> </ul>
Site Layout, Vehicular Parking	<p> <b>Pre-Consultation on Mechanised Parking System Proposals</b></p> <ul style="list-style-type: none"> <li>• QPs and developers are required to submit their mechanised parking system and car lifts proposals to LTA for a pre-submission consultation before a development application is submitted to the Urban Redevelopment Authority (URA) for planning permission. This will allow architects, engineers and developers to incorporate the necessary requirements into the design of the development upfront to minimise abortive work and major revisions to development proposals later.</li> <li>• Refer to LTA's COP for Vehicle Parking Provision in Development Proposals for the design of a proper mechanised parking system and car lifts.</li> <li>• As there is a variety of mechanised parking systems in the market, it is possible that some of these systems do not fully comply with LTA's guidelines. For such cases, the systems will be evaluated based on its own merits during the pre-submission consultation with LTA.</li> </ul>
	<p><b>Mechanised Parking System</b></p> <ul style="list-style-type: none"> <li>• To submit the detailed drawings and description for the type of mechanised parking system used in the proposal. Information on how the system operates, how cars are parked and retrieved from the system, average time taken for parking and retrieval, safety features, etc. shall be clearly illustrated.</li> </ul>

➤ For LTA's External Works requirements, please refer to [Page 160](#).





# Land Transport Authority (LTA)

Legend:



Architecture





C&S

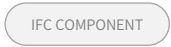

M&E



IFC COMPONENT

- Pre-Submission, Planning and Other Consultations <i>(continued from previous page)</i>	
Key Words	Requirement Category
Site Layout, Vehicular Parking  <i>(continued from previous page)</i>	<ul style="list-style-type: none"> <li>The type of mechanised parking system and all relevant requirements/ dimensions of the parking system such as platform size, maximum load, headroom clearance, allowable car dimensions, safety features, etc. shall be clearly indicated and endorsed on plan. Ensure that the dimensions and information endorsed on plan correspond with the mechanised parking system specification.</li> <li>The cross-sectional details of the parking platform showing the inner clear width of the platform, clear platform length and clear movement space between the structural supports. To ensure that the dimension for headroom clearance of minimum 2.2m and platform size of minimum 2.4m x 5.4m are cleared of obstructions e.g. structural supports, structural cage, wire rope/hoisting cable, motorised equipment, sliding gears, etc.</li> </ul> <p><b>Car Lifts</b></p> <ul style="list-style-type: none"> <li>To submit the type of car lift system and all relevant requirements/ dimensions of the car lift system such as internal cage size, width of the entrance and exit door, maximum load, headroom clearance, allowable car dimensions, minimum speed, minimum discharge capacity, queuing spaces, safety features, etc. shall be clearly indicated and endorsed on plan. Information on how to operate the car lifts (e.g. call-button or loop detector), sequence on how cars enter/exit the car lift, provision of safety devices, etc. should be clearly illustrated.</li> <li>The proposed car lift system shall comply with the guidelines for provision of car lifts in car parking places.</li> </ul>
G1 Design Gateway	
Key Words	Requirement Category
Impact Studies, Site Layout, Rail Protection	<p> <b>Development Proposal within Railway Protection Zone / Railway Corridor</b></p> <ul style="list-style-type: none"> <li>To show the proposed plan for development works</li> <li>To provide an engineering evaluation report* accompanied by a plan for engineering works</li> <li>To furnish the relevant Certified Survey Plans (for critical development within first reserve of underground RTS)</li> </ul> <p>*If the QP deems the impact from the development to be negligible, an engineering assessment outlining the method of analysis, assumptions and projected impact to the RTS will suffice at this stage. This is subject to LTA's acceptance.</p> <p>Note: Refer to LTA's Code of Practice for Railway Protection / Guidebook for Carrying Out Modification Work to Rapid Transit System (RTS) Stations or Railway by Private Developer for more requirements / detailed description</p>
Site Layout, Street Works  <div style="display: flex; justify-content: space-around;"> <div style="border: 1px solid grey; border-radius: 10px; padding: 2px 10px;">ROAD</div> <div style="border: 1px solid grey; border-radius: 10px; padding: 2px 10px;">CULVERT</div> </div> <div style="display: flex; justify-content: space-around; margin-top: 5px;"> <div style="border: 1px solid grey; border-radius: 10px; padding: 2px 10px;">SPACE</div> <div style="border: 1px solid grey; border-radius: 10px; padding: 2px 10px;">RAMP</div> </div>	<p> <b>Development Proposal</b></p> <ul style="list-style-type: none"> <li>To check if project falls within LTA's exemption list and is not required to obtain a clearance from LTA DBC, i.e. LTA in-house project.</li> <li>To confirm if the development falls within a road structure safety zone (RSSZ).</li> </ul> <p><b>Connections and Interfaces at development boundary</b></p> <ul style="list-style-type: none"> <li>To indicate the road level, entrance culvert level, and the proposed development platform level.</li> <li>For new roads proposed in conjunction with development(s), to develop the development platform level and proposed levels of the development access points based on the vertical alignment of the proposed carriageway (before QP confirms on the development platform level for the design of the foundation / structural works).</li> <li>To show the gradient of entrance approach.</li> <li>To indicate the configuration of the proposed access.</li> <li>To indicate the width and turning radius of the proposed access.</li> <li>To indicate the provision of tactile tiles.</li> <li>To indicate any proposed relocation of existing road elements, such as trees, lamp post, signs etc, which may be affected by proposed access.</li> </ul>



# Land Transport Authority (LTA)

Legend:  Architecture  C&S  M&E IFC COMPONENT

G1 Design Gateway <i>(continued from previous page)</i>	
Key Words	Requirement Category
Site Layout, Street Works  <i>(continued from previous page)</i>	<p><b><u>Proposed Loading / Unloading (Within Development): U/UL Layout</u></b></p> <ul style="list-style-type: none"> <li>To show the location of the U/UL facility</li> <li>To mark out the number of U/UL bays</li> </ul> <p><b><u>Proposed Pick-Up / Drop-Off Points (Within Development): PUDO Layout</u></b></p> <ul style="list-style-type: none"> <li>To show the location of the PUDO facility within the development site</li> <li>To mark out the number of PUDO bays and indicate the queue length</li> <li>Indicate width and kerb alignment of PUDO points</li> </ul>
Vehicular Parking  <div style="display: flex; flex-direction: column; gap: 5px;"> <div style="border: 1px solid gray; border-radius: 10px; padding: 2px 10px; background-color: #eee;">SPACE</div> <div style="border: 1px solid gray; border-radius: 10px; padding: 2px 10px; background-color: #eee;">PARKING LOT</div> <div style="border: 1px solid gray; border-radius: 10px; padding: 2px 10px; background-color: #eee;">RAMP</div> <div style="border: 1px solid gray; border-radius: 10px; padding: 2px 10px; background-color: #eee;">DRIVEWAY</div> </div>	<p><b><u>Vehicular Parking Provision</u></b></p> <ul style="list-style-type: none"> <li>To comply fully with the prevailing Parking Places (Provision of Parking Places and Parking Lots) Rules and other relevant guidelines of the Authority</li> <li>To ensure that the number of parking lots provided is within the specified range defined by the lower and upper bound requirement. (The Range-based parking provision standard for the various development uses can be found in Annex A of the COP for Vehicle Parking Provision in Development Proposals)</li> <li>To provide the details and critical dimensions of the parking layout as stipulated in the COP such as:                             <ul style="list-style-type: none"> <li>Type and size of parking lots</li> <li>Width of ramps and accessways</li> <li>Inner turning radius and width of turning paths</li> <li>Width of parking aisles</li> <li>Gradient of vehicular ramps</li> <li>Headroom clearance</li> <li>Road and traffic arrow markings</li> <li>Bicycle rack details</li> <li>Location of EV chargers</li> </ul> </li> </ul>
G1.5 Piling Gateway (Optional)	
Key Words	Requirement Category
Impact Studies, Site Layout, Rail Protection	<p><b><u>Engineering Assessment for Piling Works within Railway Protection Zone / Railway Corridor</u></b></p> <ul style="list-style-type: none"> <li>To submit plan for engineering works</li> <li>To submit the Engineering evaluation report</li> <li>To submit the Certified Survey Plans</li> <li>To submit the Construction schedule for the proposed development</li> </ul> <p>Note: Refer to LTA's Code of Practice for Railway Protection / Guidebook for Carrying Out Modification Work to Rapid Transit System (RTS) Stations or Railway by Private Developer / Guide to carrying out restricted activities within railway protection and safety zones for more requirements / detailed description</p>
G2 Construction Gateway	
Key Words	Requirement Category
Impact Studies only	<p><b><u>Building Proposal within Railway Protection Zone/ Railway Corridor</u></b></p> <ul style="list-style-type: none"> <li>To submit plans for building works.</li> <li>To submit the Engineering Evaluation Report accompanied by plan for engineering works.</li> <li>To submit the Construction Schedule for the proposed development.</li> </ul> <p>Note: Refer to LTA's Code of Practice for Railway Protection / Guidebook for Carrying Out Modification Work to Rapid Transit System (RTS) Stations or Railway by Private Developer for more requirements/ detailed description</p>

➤ For LTA's External Works requirements, please refer to [Page 160](#).

# Section 3: Specific Requirements by Regulatory Agencies

## Land Transport Authority (LTA)

INTRODUCTION TO CX

GENERAL REQUIREMENTS

• **REGULATORY AGENCIES** •

• KEY GATEWAYS •

• OTHER BUILDING WORKS •

BIM DATA REPRESENTATION



# Land Transport Authority (LTA)

Legend:



Architecture



C&S



M&E

IFC COMPONENT

G2 Construction Gateway <i>(continued from previous page)</i>	
Key Words	Requirement Category
Impact Studies, Site Layout, Rail Protection	<p><b><u>Approval to Commence Piling Works within Railway Protection Zone / Railway Corridor</u></b></p> <ul style="list-style-type: none"> <li>To submit plan for engineering works</li> <li>To submit the Engineering evaluation report</li> <li>To submit an Instrumentation Proposal and initial instrumentation readings</li> <li>To submit a Method Statement of work</li> <li>To submit a Hazard Analysis identifying all possible risks that may be posed to the rapid transit system and a description of the safety and precautionary measures to mitigate these risks</li> <li>To submit the Contingency Plan and Emergency Procedure</li> <li>To submit the Pre-condition Survey Report</li> <li>To submit the Certified Survey Plans</li> <li>To submit the Permit application form and other relevant forms</li> <li>To submit the Construction schedule for the proposed development</li> </ul> <p>Note: Refer to LTA's Code of Practice for Railway Protection / Guidebook for Carrying Out Modification Work to Rapid Transit System (RTS) Stations or Railway by Private Developer / Guide to carrying out restricted activities within railway protection and safety zones for more requirements / detailed description</p>
Site Layout, Street Works CULVERT RAMP ROAD	<p><b><u>Access Point Details</u></b></p> <ul style="list-style-type: none"> <li>Structural details of entrance culvert at access points (reinforcement, connection to entrance approach etc.)</li> <li>Levels, gradient, cross-fall</li> <li>Redundant access to be sealed and reinstated to match existing side-table</li> </ul> <p><b><u>Proposed Pick-Up / Drop-Off Points (Within Development): PUDO details</u></b></p> <ul style="list-style-type: none"> <li>To reflect all details presented at Design Gateway (G1) stage</li> </ul> <p><b><u>Street Works Deposit</u></b></p> <ul style="list-style-type: none"> <li>For private developments with proposed major road infrastructure works (e.g. new streets, major improvement of an existing street, POB, UPN), an amount to be deposited with LTA for the execution and completion of the proposed street works</li> </ul>
Site Layout, Vehicular Parking PARKING LOT RAMP ROAD	<p><b><u>Vehicular Parking Provision</u></b></p> <ul style="list-style-type: none"> <li>To provide the details and critical dimensions of the parking layout such as:               <ul style="list-style-type: none"> <li>Type and size of parking lots</li> <li>Width of ramps and accessways</li> <li>Inner turning radius and width of turning paths</li> <li>Width of parking aisles</li> <li>Gradient of vehicular ramps</li> <li>Headroom clearance</li> <li>Road and traffic arrow markings</li> <li>Bicycle rack details</li> <li>EV lots &amp; charging stations</li> </ul> </li> </ul>

➤ For LTA's External Works requirements, please refer to [Page 160](#).



# Land Transport Authority (LTA)

Legend:



Architecture



C&S



M&E

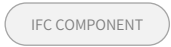

IFC COMPONENT

- Independent Submissions	
Key Words	Requirement Category
Impact Studies / Site Layout, Rail Protection, Road Structure Protection	<p><b>Approval to commence engineering works within Railway Protection Zone / Railway Corridor</b></p> <ul style="list-style-type: none"> <li>To submit plan for engineering works</li> <li>To submit the Engineering evaluation report</li> <li>To submit an Instrumentation Proposal and initial instrumentation readings</li> <li>To submit a Method Statement of work</li> <li>To submit a Hazard Analysis identifying all possible risks that may be posed to the rapid transit system and a description of the safety and precautionary measures to mitigate these risks</li> <li>To submit the Contingency Plan and Emergency Procedure</li> <li>To submit the Pre-condition Survey Report</li> <li>To submit the Certified Survey Plans</li> <li>To submit the Permit application form and other relevant forms</li> <li>To submit the Construction schedule for the proposed development</li> </ul> <p>Note: Refer to LTA's Code of Practice for Railway Protection / Guidebook for Carrying Out Modification Work to Rapid Transit System (RTS) Stations or Railway by Private Developer / Guide to carrying out restricted activities within railway protection and safety zones for more requirements / detailed description</p>
	<p><b>Approval to carry out restricted activities within Railway Safety Zone</b></p> <p>Note: Refer to LTA's Guide to carrying out restricted activities within railway protection and safety zones for detailed requirements / description</p>
	<p><b>Approval to commence engineering works within Road Structure Safety Zone / Notification to carry out engineering activity on land adjoining public street</b></p> <ul style="list-style-type: none"> <li>To submit plan for engineering works</li> <li>To submit the Engineering evaluation report</li> <li>To submit an Instrumentation Proposal and initial instrumentation readings</li> <li>To submit a Method Statement of work</li> <li>To submit a Hazard Analysis identifying all possible risks that may be posed to the rapid transit system and a description of the safety and precautionary measures to mitigate these risks</li> <li>To submit the Contingency Plan and Emergency Procedure</li> <li>To submit the Pre-condition Survey Report</li> <li>To submit the Certified Survey Plans</li> <li>To submit the Permit application form and other relevant forms</li> <li>To submit the Construction schedule for the proposed development</li> </ul> <p>Note: Refer to LTA's Guide to Carrying Out Engineering Works within Road Structure Safety Zone and Engineering Activity on Land adjoining Public Streets for more requirements/ detailed description</p>

G3 Completion Gateway	
Key Words	Requirement Category
-	<p><b>Application for clearance of certificate of statutory completion for development within Railway Protection Zone / Railway Corridor</b></p> <ul style="list-style-type: none"> <li>To submit a copy as-built topographic survey plan in true coordinates.</li> <li>To submit a certificate of supervision</li> <li>To submit the final condition survey report</li> </ul>

➤ For LTA's External Works requirements, please refer to [Page 160](#).

# Section 3: Specific Requirements by Regulatory Agencies

## Land Transport Authority (LTA)

INTRODUCTION TO CX

GENERAL REQUIREMENTS

REGULATORY AGENCIES

KEY GATEWAYS

OTHER BUILDING WORKS

BIM DATA REPRESENTATION



# Land Transport Authority (LTA)

Legend:



Architecture



C&S



M&E

IFC COMPONENT

G3 Completion Gateway (continued from previous page)	
Key Words	Requirement Category
-	<p><b>For proposed developments which involve modification to RTS, development to comply with <i>Guidebook for Carrying Out Modification Work to Rapid Transit System (RTS) Stations</i></b></p> <p>Note: Refer to LTA's Code of Practice for Railway Protection/ Guidebook for Carrying Out Modification Work to Rapid Transit System (RTS) Stations or Railway by Private Developer for more requirements / detailed description</p>
	<p><b>For Notification of Opening of New Street to Traffic, the following shall be submitted:</b></p> <ul style="list-style-type: none"> <li>Cover letter stating clearly the road opening date.</li> <li>Approved traffic layout plan</li> <li>Street and Building Name Board (SBNB) Approval letter of street name</li> <li>Certificate of Supervisions by PE</li> <li>Road Test Result</li> <li>Checklist of completed Works</li> <li>Photographs of completed works</li> </ul>
	<p><b>For developments that involve only the widening and alteration of existing street fronting the development (without new street), the following shall be submitted:</b></p> <ul style="list-style-type: none"> <li>As-built topographic survey plan in true coordinates (in .dwg format)</li> <li>Approved subdivision plan with WP from URA and Certified Plan (CP) for project with vesting of street reserve plot.</li> <li>Photographs of completed works.</li> </ul>
	<p><b>For handing over of new road, the following shall be submitted:</b></p> <ul style="list-style-type: none"> <li>As-built topographic survey plan in true coordinates (in .dwg format)</li> <li>As-built structural and M&amp;E plans for commuter facilities such as POB, UPN</li> <li>Taking over letters from PUB, NParks and NEA</li> <li>Road Declaration Plan</li> <li>Approved sub-division plan</li> <li>Certified plan from Chief Surveyor, SLA</li> <li>Asset Master Record Input Form</li> <li>Road Data Form</li> <li>Audit certificate for project under Ministries or Statutory Board</li> <li>Road testing results.</li> <li>Documents for handing over of street lightings - as-built installation plans, electrical single line diagram, letter of supervisions, test report from SP services for new control box and underground cable insulation resistance test report</li> <li>Warranties for waterproofing etc</li> </ul>
	<p><b>For Vehicle Parking submission:</b></p> <ul style="list-style-type: none"> <li>Photos for open surface parking lots</li> <li>As-built Drawings</li> </ul>

----- End of Requirements for LTA -----

Click below for LTA's RABW Requirements for :

[External Works](#)



# National Environment Agency (NEA)

Legend:



Architecture







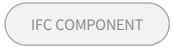

C&S



M&E



IFC COMPONENT

- Pre-Submission, Planning and Other Consultations	
Key Words	Requirement Category
Impact Studies only	 <b>Environmental Information (EI)</b> <ul style="list-style-type: none"> <li>Applicants are required to apply EI from NEA directly at Pre-Submission</li> </ul>
	 <b>Environmental Impact Study (EIS-Pre)</b> <ul style="list-style-type: none"> <li>Applicants are required to submit EIS (Pre) to NEA directly at Pre-Submission</li> <li>If Pre-Submission is not possible, the EIS (Pre) process should be concluded by Design Gateway (G1)</li> </ul>
	 <b>Energy Efficiency Opportunities Assessment (EEOA) for New Ventures</b> <ul style="list-style-type: none"> <li>Applicants are required to submit EEOA reports to NEA directly via email to <a href="mailto:DCLD_consultation@nea.gov.sg">DCLD_consultation@nea.gov.sg</a></li> </ul> <p>Note: NEA is currently reviewing the submission requirements for EEOA.</p>
	 <b>Environmental Site Assessment (ESA)</b> <ul style="list-style-type: none"> <li>Applicants should submit ESA to NEA directly and should be concluded at Pre-Submission</li> </ul>
	 <b>Noise Impact Assessment (NIA-Pre) for Traffic</b> <ul style="list-style-type: none"> <li>Applicants are required to submit NIA (Pre) report to NEA directly via email to <a href="mailto:DCLD_consultation@nea.gov.sg">DCLD_consultation@nea.gov.sg</a> at Pre-Submission</li> <li>If Pre-Submission is not possible, the NIA (Pre) process should be concluded by Design Gateway (G1)</li> <li>However, applicant may submit NIA (Pre) report to NEA directly at Construction Gateway (G2) if there is no Design Gateway (G1) submission for the development</li> </ul>
	 <b>Pollution Control Study (PCS)</b> <ul style="list-style-type: none"> <li>Applicants are required to submit PCS report to NEA directly via email to <a href="mailto:DCLD_consultation@nea.gov.sg">DCLD_consultation@nea.gov.sg</a> at Pre-Submission</li> <li>If Pre-Submission is not possible, the PCS process should be concluded by Design Gateway (G1)</li> </ul> <p>Note: NEA is currently reviewing the submission requirements for PCS.</p>
	 <b>Quantitative Risk Assessment (QRA)</b> <ul style="list-style-type: none"> <li>If QRA is required, applicants are required to submit QRA report to MOM-MHD for dissemination to respective agencies (including NEA).</li> <li>The QRA report should be accepted by agencies before Design Gateway (G1)</li> </ul> <p>Note: NEA is currently reviewing the submission requirements for QRA.</p>



# National Environment Agency (NEA)

Legend:



Architecture



C&S



M&E

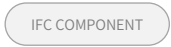

## Pre-Submission, Planning and Other Consultations *(continued from previous page)*

Key Words	Requirement Category								
Site Layout only	<p><b>Environmental Health (COPEH)</b></p> <ul style="list-style-type: none"> <li>Refuse Truck Access Road (For Refuse Collection) – Swept Path Analysis</li> <li>Location and Size of the Bin Centre / Refuse Room / Bin Point, refuse chute and recycling chute, refuse chute chamber and recyclables storage &amp; its collection system</li> <li>Provide total daily refuse outputs (liters/day) for the development</li> <li>Pneumatic waste conveyance system (PWCS) schematic plan</li> <li>Location of cooling tower and its setback distance (at least 5m)</li> </ul>								
	<table border="1"> <tr> <td><b>When to apply:</b></td> <td><b>Who to submit:</b></td> </tr> <tr> <td> <ul style="list-style-type: none"> <li>Applicants should provide the above information (either in 2D, 3D or supporting documents) and should be concluded by Design Gateway (G1)</li> <li>However, applicant may submit the above information at Pre-submission if the development does not require any Design Gateway (G1)</li> </ul> </td> <td> <ul style="list-style-type: none"> <li>QP appointed should submit the above information and keep other relevant QPs in the loop.</li> <li>The same QP should follow through the submissions for all gateways</li> </ul> </td> </tr> </table>	<b>When to apply:</b>	<b>Who to submit:</b>	<ul style="list-style-type: none"> <li>Applicants should provide the above information (either in 2D, 3D or supporting documents) and should be concluded by Design Gateway (G1)</li> <li>However, applicant may submit the above information at Pre-submission if the development does not require any Design Gateway (G1)</li> </ul>	<ul style="list-style-type: none"> <li>QP appointed should submit the above information and keep other relevant QPs in the loop.</li> <li>The same QP should follow through the submissions for all gateways</li> </ul>				
<b>When to apply:</b>	<b>Who to submit:</b>								
<ul style="list-style-type: none"> <li>Applicants should provide the above information (either in 2D, 3D or supporting documents) and should be concluded by Design Gateway (G1)</li> <li>However, applicant may submit the above information at Pre-submission if the development does not require any Design Gateway (G1)</li> </ul>	<ul style="list-style-type: none"> <li>QP appointed should submit the above information and keep other relevant QPs in the loop.</li> <li>The same QP should follow through the submissions for all gateways</li> </ul>								
	<p><b>Pollution Control (COPPC)</b></p> <ul style="list-style-type: none"> <li>Confirm the proposed development is aligned with the prevailing URA MP land use zoning (e.g. residential to residential)</li> <li>Building location and its surrounding development/amenities (such as expressway/major road, MRT/MRT station, place of worship, hospital, petrol station, industry premises etc.)</li> <li>Orientation and location of nuisance sources (e.g. cooling towers, chiller plants, air handling units, air conditioning condensers, fresh air intake, exhaust outlets (ventilation shaft), etc)</li> <li>50m nuisance buffer from place of worship, petrol station, Light industry premises to the nearest residential development.</li> <li>100m nuisance buffer from General industry premises to nearest residential development.</li> <li>500m nuisance buffer from Special Industry premises to nearest residential development.</li> <li>Orientation of building: Minimum building setback (m)</li> </ul> <table border="1"> <tr> <td>Fronting track</td> <td>35</td> </tr> <tr> <td>End-wall facing track</td> <td>25</td> </tr> </table> <ul style="list-style-type: none"> <li>Setback distance within 70m from transport-related infrastructure (i.e. LTA road reserve line for expressway/major road) to the nearest residential development Lot boundary line.</li> <li>Location of the chimney and BHC and MCH requirements e.g. within 30m / 100m radius of existing chimney stack height</li> <li>Location changes for the storage inventory product / materials such as chemical, oil, fuel, etc</li> <li>Changes in the industrial processes or production activities location</li> <li>Changes of existing activity, expansion of existing activities or proposed new activity carried out on the proposed development or premises</li> </ul> <table border="1"> <tr> <td><b>When to apply:</b></td> <td><b>Who to submit:</b></td> </tr> <tr> <td> <ul style="list-style-type: none"> <li>Applicants should provide the above information (either in 2D, 3D or supporting documents) and should be concluded by Design Gateway (G1)</li> <li>However, applicant may submit the above information at Pre-submission if the development does not require any Design Gateway (G1)</li> </ul> </td> <td> <ul style="list-style-type: none"> <li>QP appointed should submit the above information and keep other relevant QPs in the loop.</li> <li>The same QP should follow through the submissions for all gateways.</li> </ul> </td> </tr> </table>	Fronting track	35	End-wall facing track	25	<b>When to apply:</b>	<b>Who to submit:</b>	<ul style="list-style-type: none"> <li>Applicants should provide the above information (either in 2D, 3D or supporting documents) and should be concluded by Design Gateway (G1)</li> <li>However, applicant may submit the above information at Pre-submission if the development does not require any Design Gateway (G1)</li> </ul>	<ul style="list-style-type: none"> <li>QP appointed should submit the above information and keep other relevant QPs in the loop.</li> <li>The same QP should follow through the submissions for all gateways.</li> </ul>
Fronting track	35								
End-wall facing track	25								
<b>When to apply:</b>	<b>Who to submit:</b>								
<ul style="list-style-type: none"> <li>Applicants should provide the above information (either in 2D, 3D or supporting documents) and should be concluded by Design Gateway (G1)</li> <li>However, applicant may submit the above information at Pre-submission if the development does not require any Design Gateway (G1)</li> </ul>	<ul style="list-style-type: none"> <li>QP appointed should submit the above information and keep other relevant QPs in the loop.</li> <li>The same QP should follow through the submissions for all gateways.</li> </ul>								



# National Environment Agency (NEA)

Legend:  Architecture  C&S  M&E IFC COMPONENT

G1 Design Gateway	
Key Words	Requirement Category
Impact Studies only	<p> <b>Environmental Impact Study (EIS-Pre)</b></p> <p>EIS (Pre) report will be required for developments or infrastructure that would have environmental impact (air, water, land or noise) or affected by environmental impact. For example, new residential/ sensitive developments located within 50m from new / existing petrol stations and/or new petrol stations located within 50m from existing residential/sensitive sites</p> <p><b>When to apply:</b></p> <ul style="list-style-type: none"> <li>Applicants are required to submit EIS (Pre) to NEA directly at Pre-Submission</li> <li>If Pre-Submission is not possible, the EIS (Pre) process should be concluded by Design Gateway (G1)</li> </ul> <p><b>Who to submit:</b></p> <ul style="list-style-type: none"> <li>QP appointed should submit the above information and keep other relevant QPs in the loop.</li> <li>The same QP should follow through the submissions for all gateways.</li> </ul>
	<p> <b>Noise Impact Assessment (NIA-Pre) for Land Traffic Noise</b></p> <p>NIA (Pre) report will be required for (1) <u>New</u> residential and noise sensitive developments located within 70m of <u>existing</u> land traffic noise sources/hotspots (e.g. expressways / major arterial roads / MRT tracks) on existing residential and (2) <u>Existing</u> noise sensitive developments located within 70m of <u>new</u> transport-related developments (e.g. expressway/major arterial roads / MRT tracks / bus interchanges / bus depots), inclusive of the expansion of existing transport-related infrastructures</p> <p><b>When to apply:</b></p> <ul style="list-style-type: none"> <li>Applicants are required to submit NIA (Pre) report to NEA directly via email to <a href="mailto:DCLD_consultation@nea.gov.sg">DCLD_consultation@nea.gov.sg</a> at Pre-Submission and should be concluded by Design Gateway (G1)</li> <li>However, applicant may submit NIA (Pre) report to NEA directly at Construction Gateway (G2) if the development does not require any Design Gateway (G1) submission</li> <li>Sufficient time shall be catered for NEA to process the NIA (Pre)</li> <li>The processing of NIA (Pre) will take 1-2 months</li> </ul> <p><b>Who to submit:</b></p> <ul style="list-style-type: none"> <li>QP appointed should submit the above information and keep other relevant QPs in the loop.</li> <li>The same QP should follow through the submissions for all gateways.</li> </ul>
	<p> <b>Energy Efficiency Opportunities Assessment (EEOA) for New Ventures</b></p> <p>EEOA will be required for new industrial facilities and major expansions of existing facilities with an estimated annual energy consumption (AEC) ≥ 54TJ must review the facility design and develop economically feasible for energy efficiency opportunities</p> <ul style="list-style-type: none"> <li>Applicants are required to submit EEOA report to NEA directly via email to <a href="mailto:DCLD_consultation@nea.gov.sg">DCLD_consultation@nea.gov.sg</a>.</li> </ul> <p><b>When to apply:</b></p> <ul style="list-style-type: none"> <li>Applicants are required to submit EEOA to NEA directly at Pre-Submission</li> </ul> <p><b>Who to submit:</b></p> <ul style="list-style-type: none"> <li>QP appointed should submit the above information and keep other relevant QPs in the loop.</li> <li>The same QP should follow through the submissions for all gateways.</li> </ul>





# National Environment Agency (NEA)

Legend:



Architecture





C&S

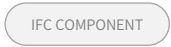

M&E



G1 Design Gateway <i>(continued from previous page)</i>	
Key Words	Requirement Category
Impact Studies only  <i>(continued from previous page)</i>	<p> <b>Environmental Site Assessment (ESA)</b></p> <p>ESA should be conducted when a site that is used for polluting activities is to be redeveloped, rezoned or reused for a non-polluting activity</p> <p><b>When to apply:</b></p> <ul style="list-style-type: none"> <li>Applicants should conclude the ESA at Pre-Submission</li> </ul> <p><b>Who to submit:</b></p> <ul style="list-style-type: none"> <li>QP appointed should submit the above information and keep other relevant QPs in the loop.</li> <li>The same QP should follow through the submissions for all gateways.</li> </ul>
	<p> <b>Pollution Control Study (PCS)</b></p> <p>Any proposed industrial development that could cause serious or substantial pollution of the environment, if mismanagement, is required to conduct a Pollution Control Study (PCS)</p> <ul style="list-style-type: none"> <li>Applicants are required to submit PCS report to NEA directly via email to <a href="mailto:DCLD_consultation@nea.gov.sg">DCLD_consultation@nea.gov.sg</a> at Pre-Submission</li> <li>If Pre-Submission is not possible, the PCS process should be concluded by Design Gateway (G1)</li> </ul> <p><b>When to apply:</b></p> <ul style="list-style-type: none"> <li>Applicants are required to submit PCS report to NEA directly at Pre-Submission</li> <li>If Pre-Submission is not possible, the PCS process should be concluded by Design Gateway (G1)</li> </ul> <p><b>Who to submit:</b></p> <ul style="list-style-type: none"> <li>QP appointed should submit the above information and keep other relevant QPs in the loop.</li> <li>The same QP should follow through the submissions for all gateways.</li> </ul>
	<p> <b>Quantitative Risk Assessment (QRA)</b></p> <ul style="list-style-type: none"> <li>Anyone intending to store or use hazardous substances will have to pre-consult MOM-MHD whether a QRA assessment is required.</li> </ul> <p><b>When to apply:</b></p> <ul style="list-style-type: none"> <li>If QRA is required, applicants are required to submit QRA report to MOM-MHD for dissemination to respective agencies (including NEA).</li> <li>The QRA report should be accepted by agencies before Design Gateway (G1)</li> </ul> <p><b>Who to submit:</b></p> <ul style="list-style-type: none"> <li>QP appointed should submit the above information and keep other relevant QPs in the loop.</li> <li>The same QP should follow through the submissions for all gateways.</li> </ul>
Site Layout only	<p><b>Environmental Information (EI)</b></p> <ul style="list-style-type: none"> <li>EI information such as building height constraint, health and safety buffer, etc. shall be incorporated in the building plan design to ensure that the development is able to meet the requirement.</li> </ul> <p><b>When to apply:</b></p> <ul style="list-style-type: none"> <li>Applicants are required to apply EI from NEA directly at Pre-Submission and incorporate the information in building plan submission in Design Gateway (G1)</li> <li>However, applicant may submit the above information at Pre-Submission if the development does not require any Design Gateway (G1)</li> </ul>



# National Environment Agency (NEA)

Legend:



Architecture



C&S



M&E

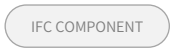

IFC COMPONENT

## G1 Design Gateway *(continued from previous page)*

Key Words	Requirement Category				
<p>Site Layout only</p> <p><i>(continued from previous page)</i></p> <div style="display: flex; flex-direction: column; gap: 5px;"> <div style="border: 1px solid #ccc; border-radius: 10px; padding: 2px 10px; background-color: #f9f9f9;">SITE</div> <div style="border: 1px solid #ccc; border-radius: 10px; padding: 2px 10px; background-color: #f9f9f9;">SPACE</div> <div style="border: 1px solid #ccc; border-radius: 10px; padding: 2px 10px; background-color: #f9f9f9;">ROAD</div> <div style="border: 1px solid #ccc; border-radius: 10px; padding: 2px 10px; background-color: #f9f9f9;">REFUSE CHUTE</div> <div style="border: 1px solid #ccc; border-radius: 10px; padding: 2px 10px; background-color: #f9f9f9;">DOOR</div> </div>	<p><b><u>Environmental Health (COPEH)</u></b></p> <ul style="list-style-type: none"> <li>Refuse Truck Access road (for refuse collection) – Swept Path Analysis</li> <li>Location and Size of the Bin Centre /Refuse Room / Bin Point, refuse chute and recycling chute, refuse chute chamber and recyclables storage &amp; its collection system</li> <li>Provide total daily refuse outputs (liters / day) for the development</li> <li>Location and dimensions of spatial provisions of Pneumatic waste conveyance system (PWCS) to meet the minimum requirements specified in Singapore Standard - Code of Practice for Pneumatic Waste Conveyance System (SS 642: 2019)</li> <li>Location of cooling tower and its setback distance (at least 5m)</li> </ul> <p>Note: NEA is currently reviewing the submission requirements for PWCS.</p> <div style="display: flex; justify-content: space-between;"> <div style="width: 45%;"> <p><b>When to apply:</b></p> <ul style="list-style-type: none"> <li>Applicants should provide the above information (either in 2D, 3D or supporting documents) and should be concluded by Design Gateway (G1)</li> <li>However, applicant may submit the above information at Pre-Submission if the development does not require any Design Gateway (G1)</li> </ul> </div> <div style="width: 45%;"> <p><b>Who to submit:</b></p> <ul style="list-style-type: none"> <li>QP appointed should submit the above information and keep other relevant QPs in the loop.</li> <li>The same QP should follow through the submissions for all gateways.</li> </ul> </div> </div> <p><b><u>Pollution Control (COPPC)</u></b></p> <ul style="list-style-type: none"> <li>Confirm the proposed development is aligned with the prevailing URA MP land use zoning (e.g. residential to residential)</li> <li>Building location and its surrounding development/amenities (such as expressway / major road, MRT / MRT station, place of worship, hospital, petrol station, industry premises etc.)</li> <li>Orientation and location of nuisance sources (e.g. cooling towers, chiller plants, air handling units, air conditioning condensers, fresh air intake, exhaust outlets (ventilation shaft), etc)</li> <li>50m nuisance buffer from place of worship, petrol station, Light industry premises to the nearest residential development.</li> <li>100m nuisance buffer from General industry premises to nearest residential development.</li> <li>500m nuisance buffer from Special Industry premises to nearest residential development.</li> <li>Orientation of building: Minimum building setback (m)</li> </ul> <table border="1" style="margin-left: 20px; margin-bottom: 10px;"> <tbody> <tr> <td>Fronting track</td> <td>35</td> </tr> <tr> <td>End-wall facing track</td> <td>25</td> </tr> </tbody> </table> <ul style="list-style-type: none"> <li>Setback distance within 70m from transport-related infrastructure (i.e. LTA road reserve line for expressway/major road) to the nearest residential development Lot boundary line.</li> <li>Location of the chimney and BHC and MCH requirements e.g. within 30m / 100m radius of existing chimney stack height</li> <li>Location changes for the storage inventory product / materials such as chemical, oil, fuel, etc</li> <li>Changes in the industrial processes or production activities location</li> <li>Changes of existing activity, expansion of existing activities or proposed new activity carried out on the proposed development or premises</li> </ul> <div style="display: flex; justify-content: space-between;"> <div style="width: 45%;"> <p><b>When to apply:</b></p> <ul style="list-style-type: none"> <li>Applicants should provide the above information (either in 2D, 3D or supporting documents) and should be concluded by Design Gateway (G1)</li> <li>However, applicant may submit the above information at Pre-submission if the development does not require any Design Gateway (G1)</li> </ul> </div> <div style="width: 45%;"> <p><b>Who to submit:</b></p> <ul style="list-style-type: none"> <li>QP appointed should submit the above information and keep other relevant QPs in the loop.</li> <li>The same QP should follow through the submissions for all gateways.</li> </ul> </div> </div>	Fronting track	35	End-wall facing track	25
Fronting track	35				
End-wall facing track	25				



# National Environment Agency (NEA)

Legend:  Architecture  C&S  M&E IFC COMPONENT

G2 Construction Gateway	
Key Words	Requirement Category
Impact Studies only	<p><b><u>Energy Efficiency Opportunities Assessment (EEOA) for New Ventures</u></b></p> <p>EEOA will be required for new industrial facilities and major expansions of existing facilities with an estimated annual energy consumption (AEC) ≥ 54TJ must review the facility design and develop economically feasible for energy efficiency opportunities</p> <ul style="list-style-type: none"> <li>Applicants are required to submit EEOA report to NEA directly via email to <a href="mailto:DCLD_consultation@nea.gov.sg">DCLD_consultation@nea.gov.sg</a>.</li> </ul>
<p>Environmental Health (COPEH)</p> <div style="display: flex; flex-wrap: wrap; gap: 5px;"> <div style="border: 1px solid #ccc; border-radius: 10px; padding: 2px 5px; margin: 2px;">INTERCEPTOR</div> <div style="border: 1px solid #ccc; border-radius: 10px; padding: 2px 5px; margin: 2px;">SENSOR</div> <div style="border: 1px solid #ccc; border-radius: 10px; padding: 2px 5px; margin: 2px;">PUMP</div> <div style="border: 1px solid #ccc; border-radius: 10px; padding: 2px 5px; margin: 2px;">CUBICLE</div> <div style="border: 1px solid #ccc; border-radius: 10px; padding: 2px 5px; margin: 2px;">SANITARY APPLIANCES</div> <div style="border: 1px solid #ccc; border-radius: 10px; padding: 2px 5px; margin: 2px;">DISTRIBUTION CHAMBER</div> <div style="border: 1px solid #ccc; border-radius: 10px; padding: 2px 5px; margin: 2px;">GUTTER</div> <div style="border: 1px solid #ccc; border-radius: 10px; padding: 2px 5px; margin: 2px;">SYSTEM</div> <div style="border: 1px solid #ccc; border-radius: 10px; padding: 2px 5px; margin: 2px;">TANK</div> <div style="border: 1px solid #ccc; border-radius: 10px; padding: 2px 5px; margin: 2px;">SPACE</div> <div style="border: 1px solid #ccc; border-radius: 10px; padding: 2px 5px; margin: 2px;">SHADING DEVICE</div> <div style="border: 1px solid #ccc; border-radius: 10px; padding: 2px 5px; margin: 2px;">CONTROL ELEMENT</div> <div style="border: 1px solid #ccc; border-radius: 10px; padding: 2px 5px; margin: 2px;">REFUSE CHUTE / RECYCLABLES CHUTE</div> <div style="border: 1px solid #ccc; border-radius: 10px; padding: 2px 5px; margin: 2px;">REFUSE HANDLING EQUIPMENT</div> </div>	<p><b><u>COPEH - Section 1 : Refuse Storage and Collection</u></b></p> <p>The spatial provision set aside for Pneumatic waste conveyance system (PWCS) cleared at Design Gateway (G1) must continue to be provided at CG. Applicants are required to furnish details regarding their proposals, building upon the spatial provisions previously submitted at DG.</p> <div style="display: flex; justify-content: space-between;"> <div style="width: 45%;"> <p>1.1 Objective</p> <p>1.2 Refuse Output</p> <p>1.3 Refuse Chute</p> <p>1.4 Refuse Chute Chamber</p> <p>1.5 Refuse Room</p> </div> <div style="width: 45%;"> <p>1.6 Refuse Bin Point and Refuse Bin Centre</p> <p>1.7 Pneumatic Waste Conveyance System (PWCS)</p> <p>1.8 Mandatory Waste Reporting Scheme</p> <p>1.9 Location of Grease Trap</p> <p>1.10 On-Site Food Waste Treatment System</p> </div> </div> <p>Note: NEA is currently reviewing the submission requirements for PWCS.</p> <p><b>When to apply:</b></p> <ul style="list-style-type: none"> <li>Applicants should provide the above information (either in 2D, 3D or supporting documents) and should be concluded by Construction Gateway (G2).</li> </ul> <p><b>Who to submit:</b></p> <ul style="list-style-type: none"> <li>QP appointed should submit the above information and keep other relevant QPs in the loop.</li> <li>The same QP should follow through the submissions for all gateways.</li> </ul>
	<p><b><u>COPEH - Section 2 : Public Toilet</u></b></p> <div style="display: flex; justify-content: space-between;"> <div style="width: 45%;"> <p>2.1 Objective</p> <p>2.2 Definition of Public Toilet</p> <p>2.3 General Design Criteria</p> </div> <div style="width: 45%;"> <p>2.4 Sanitary and Water Fittings Required in Public Toilet</p> <p>2.5 Amenities to be Provided</p> <p>2.6 Ventilation</p> </div> </div>



# National Environment Agency (NEA)

Legend:



Architecture



C&S



M&E

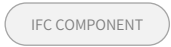

IFC COMPONENT

## G2 Construction Gateway *(continued from previous page)*

Key Words	Requirement Category
Environmental Health (COPEH)  <i>(continued from previous page)</i>	<p><b>When to apply:</b></p> <ul style="list-style-type: none"> <li>Applicants should provide the above information (either in 2D, 3D or supporting documents) and should be concluded by Construction Gateway (G2).</li> </ul> <p><b>Who to submit:</b></p> <ul style="list-style-type: none"> <li>QP appointed should submit the above information and keep other relevant QPs in the loop.</li> <li>The same QP should follow through the submissions for all gateways.</li> </ul>
	<p><b><u>COPEH - Section 3 : Ventilation, Ducting and Kitchen Exhaust Systems for Food Shop</u></b></p> <p>3.1 Objective 3.2 Design Requirements</p> <p><b>When to apply:</b></p> <ul style="list-style-type: none"> <li>Applicants should provide the above information (either in 2D, 3D or supporting documents) and should be concluded by Construction Gateway (G2). <b>Terminals and façade louvres are to be modelled. Ducting can be in 2D or 3D.</b></li> </ul> <p><b>Who to submit:</b></p> <ul style="list-style-type: none"> <li>QP appointed should submit the above information and keep other relevant QPs in the loop.</li> <li>The same QP should follow through the submissions for all gateways.</li> </ul>
	<p><b><u>COPEH - Section 4 : Cooling Tower <i>(when it is provided)</i></u></b></p> <p>4.1 Objective 4.2 Design Requirements</p> <p><b>When to apply:</b></p> <ul style="list-style-type: none"> <li>Applicants should provide the above information (either in 2D, 3D or supporting documents) and should be concluded by Construction Gateway (G2)</li> </ul> <p><b>Who to submit:</b></p> <ul style="list-style-type: none"> <li>QP appointed should submit the above information and keep other relevant QPs in the loop.</li> <li>The same QP should follow through the submissions for all gateways.</li> </ul>
	<p><b><u>COPEH - Section 5 : Aquatic Facility</u></b></p> <p>5.1 Objective 5.2 Minimum Design Criteria</p> <p><b>When to apply:</b></p> <ul style="list-style-type: none"> <li>Applicants should provide the above information (either in 2D, 3D or supporting documents) and should be concluded by Construction Gateway (G2). <b>Balancing Tank is to be modelled.</b></li> </ul> <p><b>Who to submit:</b></p> <ul style="list-style-type: none"> <li>QP appointed should submit the above information and keep other relevant QPs in the loop.</li> <li>The same QP should follow through the submissions for all gateways.</li> </ul>
	<p><b><u>COPEH - Section 6 : Storage and Collection System for Recyclables at Strata-Titled properties with Residential Units</u></b></p> <p>6.1 Objective 6.2 Recyclables Output</p> <p><b>When to apply:</b></p> <ul style="list-style-type: none"> <li>Applicants should provide the above information (either in 2D, 3D or supporting documents) and should be concluded by Construction Gateway (G2).</li> </ul> <p><b>Who to submit:</b></p> <ul style="list-style-type: none"> <li>QP appointed should submit the above information and keep other relevant QPs in the loop.</li> <li>The same QP should follow through the submissions for all gateways.</li> </ul>



# National Environment Agency (NEA)

Legend:  Architecture  C&S  M&E IFC COMPONENT

G2 Construction Gateway <i>(continued from previous page)</i>	
Key Words	Requirement Category
Environmental Health (COPEH)  <i>(continued from previous page)</i>	<p><b><u>COPEH - Section 7 : Anti-Mosquito Breeding</u></b></p> <p>7.1 Objective 7.2 Roof Gutter</p> <p><b>When to apply:</b></p> <ul style="list-style-type: none"> <li>Applicants should provide the above information (either in 2D, 3D or supporting documents) and should be concluded by Construction Gateway (G2).</li> </ul> <p>7.3 Air-Conditioning Tray 7.4 Floor Trap</p> <p><b>Who to submit:</b></p> <ul style="list-style-type: none"> <li>QP appointed should submit the above information and keep other relevant QPs in the loop.</li> <li>The same QP should follow through the submissions for all gateways.</li> </ul>
Pollution Control (COPPC)	<p><b><u>COPPC - Section 2 : Judicious Siting of Industries and Other Development</u></b></p> <p>4. Objective</p> <p><b>When to apply:</b></p> <ul style="list-style-type: none"> <li>Applicants should provide the above information (either in 2D, 3D or supporting documents) and should be concluded by Construction Gateway (G2).</li> </ul> <p><b>Who to submit:</b></p> <ul style="list-style-type: none"> <li>QP appointed should submit the above information and keep other relevant QPs in the loop.</li> <li>The same QP should follow through the submissions for all gateways.</li> </ul>
	<p><b><u>COPPC - Section 3 : Requirements for Industries</u></b></p> <p>5. Clean Industry 6. Light Industry</p> <p><b>When to apply:</b></p> <ul style="list-style-type: none"> <li>Applicants should provide the above information (either in 2D, 3D or supporting documents) and should be concluded by Construction Gateway (G2)</li> </ul> <p>7. General Industry 8. Special Industry</p> <p><b>Who to submit:</b></p> <ul style="list-style-type: none"> <li>QP appointed should submit the above information and keep other relevant QPs in the loop.</li> <li>The same QP should follow through the submissions for all gateways.</li> </ul>
	<p><b><u>COPPC - Section 4 : Requirements to Operate a Factory</u></b></p> <p>9. Use of Industrial premises 10. Trade effluent discharge into public sewer and watercourse</p> <p><b>When to apply:</b></p> <ul style="list-style-type: none"> <li>Applicants should provide the above information (either in 2D, 3D or supporting documents) and should be concluded by Construction Gateway (G2)</li> </ul> <p><b>Who to submit:</b></p> <ul style="list-style-type: none"> <li>QP appointed should submit the above information and keep other relevant QPs in the loop.</li> <li>The same QP should follow through the submissions for all gateways.</li> </ul>
	<p><b><u>COPPC - Section 5 : Pollution Control Requirements</u></b></p> <ul style="list-style-type: none"> <li>11. Water Pollution</li> <li>12. Air Pollution</li> <li>13. Noise Pollution</li> </ul> <p><b>When to apply:</b></p> <ul style="list-style-type: none"> <li>Applicants should provide the above information (either in 2D, 3D or supporting documents) and should be concluded by Construction Gateway (G2)</li> </ul> <p><b>Who to submit:</b></p> <ul style="list-style-type: none"> <li>QP appointed should submit the above information and keep other relevant QPs in the loop.</li> <li>The same QP should follow through the submissions for all gateways.</li> </ul>



# National Environment Agency (NEA)

Legend:



Architecture





C&S



M&E

IFC COMPONENT

G2 Construction Gateway <i>(continued from previous page)</i>	
Key Words	Requirement Category
Pollution Control (COPPC)  <i>(continued from previous page)</i>	<p><b>COPPC - Section 6 : Hazardous Substances and Toxic Industrial Waste Control Requirements</b></p> <ul style="list-style-type: none"> <li>14. Hazardous Substances</li> <li>15. Toxic Industrial Waste</li> </ul> <p><b>When to apply:</b></p> <ul style="list-style-type: none"> <li>Applicants should provide the above information (either in 2D, 3D or supporting documents) and should be concluded by Construction Gateway (G2)</li> </ul> <p><b>Who to submit:</b></p> <ul style="list-style-type: none"> <li>QP appointed should submit the above information and keep other relevant QPs in the loop.</li> <li>The same QP should follow through the submissions for all gateways.</li> </ul>

- Independent Submissions	
Key Words	Requirement Category
Impact Studies only	<p> <b>Noise Impact Assessment (NIA-Post) for Land Traffic Noise</b></p> <p>NIA (Post) report will be required for (1) <u>New</u> residential and noise sensitive developments located within 70m of <u>existing</u> land traffic noise sources/hotspots (e.g. expressways/major arterial roads/MRT tracks) on existing residential and (2) <u>Existing</u> noise sensitive developments located within 70m of <u>new</u> transport-related developments (e.g. expressway/major arterial roads/MRT tracks/bus interchanges/ bus depots), inclusive of the expansion of existing transport-related infrastructures</p> <p><b>When to apply:</b></p> <ul style="list-style-type: none"> <li>Applicant will need to submit NIA (Post) report to NEA directly via email to <a href="mailto:DCLD_consultation@nea.gov.sg">DCLD_consultation@nea.gov.sg</a> before Completion Gateway (G3) and concluded before TOP can be granted.</li> <li>Sufficient time shall be catered for NEA to process the NIA (Post)</li> <li>The processing of NIA (Post) will take 1-2 months</li> </ul> <p><b>Who to submit:</b></p> <ul style="list-style-type: none"> <li>QP appointed should submit the above information and keep other relevant QPs in the loop.</li> <li>The same QP should follow through the submissions for all gateways.</li> </ul>
	<p> <b>Noise Report for ACMV</b></p> <p>Noise report for ACMV will be required for non-industrial developments which have new air-conditioning and mechanical ventilation works, including relocations.</p> <p><b>When to apply:</b></p> <ul style="list-style-type: none"> <li>Applicant will need to submit ACMV noise report directly to NEA before Completion Gateway (G3) and concluded before TOP could be granted.</li> </ul> <p><b>Who to submit:</b></p> <ul style="list-style-type: none"> <li>QP appointed should submit the above information and keep other relevant QPs in the loop.</li> <li>The same QP should follow through the submissions for all gateways.</li> </ul>
	<p> <b>Pollution Control Equipment (PCE)</b></p> <p>PCE submission will be required for developments involving proposed PCE/fuel burning equipment (e.g. Boiler, Thermal Oxidiser, Scrubber, Dust Collector, Spray Paint Booth, etc.)</p> <p><b>When to apply:</b></p> <ul style="list-style-type: none"> <li>Applicant will need to submit technical details of the PCE and/or Fuel Burning Equipment to NEA directly before Completion Gateway (G3) and concluded before TOP could be granted.</li> </ul> <p><b>Who to submit:</b></p> <ul style="list-style-type: none"> <li>QP appointed should submit the above information and keep other relevant QPs in the loop.</li> <li>The same QP should follow through the submissions for all gateways.</li> </ul>



## National Environment Agency (NEA)

Legend:



Architecture





C&S



M&E

IFC COMPONENT

G3 Completion Gateway		
	Key Words	Requirement Category
  	Photo, video or reports of completed works	<ul style="list-style-type: none"><li>QP (Arch/PEs) applies for TOP/CSC and provide photo / video evidence or reports of completed works</li></ul>

----- **End of Requirements for NEA** -----

# Section 3: Specific Requirements by Regulatory Agencies

## National Parks Board (NParks)

INTRODUCTION TO CX

GENERAL REQUIREMENTS

• **REGULATORY AGENCIES** •

• KEY GATEWAYS •

• OTHER BUILDING WORKS •

BIM DATA REPRESENTATION



# National Parks Board (NParks)

Legend:



Architecture





C&S



M&E

IFC COMPONENT

- Pre-Submission, Planning and Other Consultations	
Key Words	Requirement Category
Greenery	<p><b><u>Greenery Provision and Conservation of Trees</u></b></p> <ul style="list-style-type: none"> <li>Pre-Submission consultation of requirements for greenery provision and tree conservation for developments</li> </ul>
Impact Studies only	<p> <b><u>Biodiversity Impact Assessment (under URA's Environmental Impact Assessment [EIA] framework)</u></b></p> <ul style="list-style-type: none"> <li>Applicable to sites that fall within the EIA framework but were not identified at Planning Stage (Pre-DG)                             <ul style="list-style-type: none"> <li><u>Environmental Consultation</u> <ul style="list-style-type: none"> <li>QP (Arch / PEs) or Consultant to submit the environmental consultation form (Form A) to URA and relevant Technical Agencies (i.e. NEA, NParks, MPA, SFA).</li> <li>Details of project entities (Developer, Qualified Person and Main Contractor) as stated in Form A are provided</li> </ul> </li> <li><u>Environmental Impact Assessment</u> <ul style="list-style-type: none"> <li>If determined during environmental consultation that an environmental study is needed, QP (Arch / PEs) or Consultant can consult on environmental baseline study and scoping of EIA</li> <li>QP (Arch / PEs) or Consultant to ensure that EIA report (for projects that have cleared environmental assessment at planning stage) are submitted for acceptance</li> </ul> </li> </ul> </li> <li>If pre-submission is not possible, the environmental consultation process should be concluded by Piling Gateway (G1.5) or Construction Gateway (G2)</li> <li>There might be requirement for detailed EMMP / wildlife management prior to site clearance</li> </ul>
	<p> <b><u>Assessment and Reduction of Biodiversity Impact (under URA's Environmental Impact Assessment [EIA] framework)</u></b></p> <ul style="list-style-type: none"> <li>Should be surfaced ahead of the submission</li> <li>If pre-submission is not possible, the environmental consultation process should be concluded by Design Gateway (G1) or Piling Gateway (G1.5)</li> <li>There might be requirement for EMMP / wildlife management prior to site clearance</li> </ul>

G1 Design Gateway	
Key Words	Requirement Category
<p>Greenery</p> <p>LANDSCAPE PLANTS</p>	<p><b><u>Conservation of Trees</u></b></p> <ul style="list-style-type: none"> <li>To conserve trees identified:                             <ul style="list-style-type: none"> <li>In Technical Conditions of Tender (TCOT)</li> <li>As Heritage Trees</li> <li>Through nature group / public / residents engagement</li> <li>In Environmental Impact Assessments (EIA) / Environmental Management and Monitoring Plans (EMMP) etc.</li> </ul> </li> </ul> <p> <b><u>Supporting Document(s):</u></b></p> <p>a) Arborist report (Please refer to NParks' Guidelines [Chapter 2])</p>

➤ For NParks' External Works requirements, please refer to [Page 170](#).





# National Parks Board (NParks)

Legend:  Architecture  C&S  M&E IFC COMPONENT

G1 Design Gateway <i>(continued from previous page)</i>	
Key Words	Requirement Category
Impact Studies only	<ul style="list-style-type: none"> <li>☑ <b>Biodiversity Impact Assessment (under URA's Environmental Impact Assessment [EIA] framework)</b> <ul style="list-style-type: none"> <li>• Applicable to sites that fall within the EIA Framework but were not identified at Planning Stage (Pre-DG)                             <ul style="list-style-type: none"> <li><u>Environmental Consultation</u> <ul style="list-style-type: none"> <li>○ QP (Arch / PEs) or Consultant to submit the environmental consultation form (Form A) to URA and Technical Agencies (e.g. NEA, NParks, MPA, SFA)</li> <li>○ Details of project entities (Developer, Qualified Person and Main Contractor) as stated in Form A are provided</li> </ul> </li> <li><u>Environmental Impact Assessment (EIA)</u> <ul style="list-style-type: none"> <li>○ If determined during environmental consultation that an environmental study is needed, QP (Arch / PEs) or Consultant can consult on environmental baseline study and scoping of EIA</li> <li>○ QP (Arch / PEs) or Consultant to ensure that EIA report (for projects that have cleared environmental assessment at planning stage) are submitted for acceptance</li> </ul> </li> </ul> </li> </ul> </li> </ul>
Site Layout only  <div style="border: 1px solid gray; border-radius: 10px; padding: 5px; width: fit-content; margin-bottom: 5px;">SITE BOUNDARY</div> <div style="border: 1px solid gray; border-radius: 10px; padding: 5px; width: fit-content; margin-bottom: 5px;">PLANTING AREA</div> <div style="border: 1px solid gray; border-radius: 10px; padding: 5px; width: fit-content;">GREEN VERGE</div>	<ul style="list-style-type: none"> <li>• <b>Provision of Planting Areas</b> <ul style="list-style-type: none"> <li>• To provide development boundary lines</li> <li>• To provide existing and proposed road reserve lines</li> <li>• To provide road name(s) and category of existing and proposed roads</li> <li>• To provide planting areas (i.e. 3.0m/5.0m-wide green buffers, 2.0m-wide peripheral planting verges, open-air parking planting areas) in compliance with NParks' Guidelines (Chapter 3)</li> <li>• To ensure planting areas are free from any encroachment, except for allowable minor ancillary structures and landscaping structures as listed in NParks' Guidelines (Chapter 3). To show the allowable structures within planting areas</li> <li>• To locate fire engine accessways and non-allowable structures outside planting areas</li> <li>• To recess underground structures / services at least 2.0m below planting areas, except for:                             <ul style="list-style-type: none"> <li>○ Footings of retaining / boundary walls (may encroach up to 0.5m into planting areas)</li> <li>○ Services traversing perpendicularly across planting areas</li> </ul> </li> </ul> </li> <li>• Applicants should provide the above information (either in 2D, 3D or supporting documents) and should be concluded by Design Gateway (G1)</li> </ul> <ul style="list-style-type: none"> <li>• <b>New Parks/ Park Connectors/ Promenades</b> <ul style="list-style-type: none"> <li>• To ensure design is in accordance with NParks specifications (e.g., spatial provision, access points, specific features / elements imposed at planning stage based on NParks planning conditions)</li> </ul> </li> <li>• <b>Securing of Land for Parks / Park Connectors use and/or Impact on Neighbouring Parks (e.g., en bloc sites)</b> <ul style="list-style-type: none"> <li>• To ensure site boundary does not encroach into safeguarded / rezoned parks and park connectors</li> </ul> </li> <li>• <b>Green Verges</b> <ul style="list-style-type: none"> <li>• To provide green verges (consisting of tree planting and service verges) for street work proposals relating to development works and for new road services according to the road category</li> <li>• To locate fire engine accessways outside green verges</li> </ul> </li> <li>• <b>Road and Commuter Infrastructure</b> <ul style="list-style-type: none"> <li>• To comply with greenery provision for covered linkways, bus shelters, pedestrian overhead bridges, depressed road portals, road viaducts/flyovers and retaining walls etc. according to NParks' Guidelines (Chapter 4)</li> </ul> </li> <li>• <b>Entrance Culvert Position (at Vehicular Access Points)</b> <ul style="list-style-type: none"> <li>• To ensure splay corners do not affect green verge provision and roadside trees</li> </ul> </li> </ul>

➤ For NParks' External Works requirements, please refer to [Page 170](#).

# Section 3: Specific Requirements by Regulatory Agencies

## National Parks Board (NParks)

INTRODUCTION TO CX

GENERAL REQUIREMENTS

• **REGULATORY AGENCIES** •

• KEY GATEWAYS •

• OTHER BUILDING WORKS •

BIM DATA REPRESENTATION



## National Parks Board (NParks)

Legend:



Architecture



C&S



M&E

IFC COMPONENT

### G1.5 Piling Gateway (Optional)

Key Words	Requirement Category
Impact Studies only	<ul style="list-style-type: none"> <li>☑️ <b>Applicable to sites requiring Environmental Monitoring and Management Plan (EMMP) / Wildlife Management Plan prior to commencement of works:</b> <ul style="list-style-type: none"> <li>a) Detailed EMMP report (provided by Main Contractor)</li> <li>b) Acceptance letter from NParks prior to site clearance (if applicable)</li> </ul> </li> </ul>

### G2 Construction Gateway

Key Words	Requirement Category
Greenery LANDSCAPE PLANTS	<b>Conservation of Trees</b> <ul style="list-style-type: none"> <li>• To conserve trees identified:               <ul style="list-style-type: none"> <li>○ In Technical Conditions of Tender (TCOT)</li> <li>○ As Heritage Trees</li> <li>○ Through public engagement</li> <li>○ In Environmental Impact Assessments (EIA) / Environmental Management and Monitoring Plans (EMMP) etc.</li> </ul> </li> </ul> <ul style="list-style-type: none"> <li>☑️ <b>Supporting Document(s):</b> <ul style="list-style-type: none"> <li>a) Arborist report (Please refer to NParks' Guidelines [Chapter 2])</li> </ul> </li> </ul>
Impact Studies only	<i>Applicable to sites not requiring Piling Gateway (G1.5) approval</i>  <b>Applicable to sites requiring Environmental Monitoring and Management Plan (EMMP) / Wildlife Management Plan prior to commencement of works:</b> <ul style="list-style-type: none"> <li>☑️               <ul style="list-style-type: none"> <li>a) Detailed EMMP report (provided by Main Contractor)</li> <li>b) Acceptance letter from NParks prior to site clearance (if applicable)</li> </ul> </li> </ul>
Site Layout only PLANTING AREA GREEN VERGE	<b>Provision of Planting Areas / Green Verges</b> <ul style="list-style-type: none"> <li>• To ensure dimensions of planting areas are compliant with NParks Guidelines (Chapter 3) or as approved by NParks during Design Gateway (G1)</li> </ul>

### Independent Submissions

Key Words	Requirement Category
Greenery	<b>Planting Scheme (within Development Boundary)</b> <ul style="list-style-type: none"> <li>• To show location, number and species of existing and proposed trees / shrubs for planting areas</li> </ul>



# National Parks Board (NParks)

Legend:  Architecture  C&S  M&E IFC COMPONENT

G3 Completion Gateway	
Key Words	Requirement Category
TOP/CSC	<ul style="list-style-type: none"><li>As-built plan</li><li>Photo evidence to demonstrate compliance with NParks' requirements/approved submission(s) at preceding Gateway(s)</li><li>Site inspections (if applicable) – may involve soil check to ensure quality of planting mixture conforms to NParks' specifications for Approved Soil Mixture (ASM)</li></ul>

----- **End of Requirements for NParks** -----

**Click below for NParks RABW Requirements for :**

[External Works](#)

# Section 3: Specific Requirements by Regulatory Agencies

## Public Utilities Board (PUB)

INTRODUCTION TO CX

GENERAL REQUIREMENTS

• **REGULATORY AGENCIES** •

• KEY GATEWAYS •

• OTHER BUILDING WORKS •

BIM DATA REPRESENTATION



## Public Utilities Board (PUB)

Legend: ■ Architecture ■ C&S ■ M&E

- Pre-Submission, Planning and Other Consultations	
Key Words	Requirement Category
Platform Levels	<p><b>Minimum Platform Level</b></p> <ul style="list-style-type: none"> <li>SHD</li> </ul>
Public Drains (External) CULVERT	<p><b>Roadside Drain Capacity</b></p> <ul style="list-style-type: none"> <li>For projects where drains need to be rebuilt / entrance culvert. PUB to provide required size during pre-sub consultation</li> <li>Size of new culvert (will be advised by PUB)</li> <li>Public Drains - Drain Size and Location</li> </ul> <p><b>Pre-Consultation for Drainage</b></p> <ul style="list-style-type: none"> <li>Drainage Discharge Point</li> <li>Catchment Area</li> </ul>
Public Sewerage System (External)	<p><b>Pre-Consultation for Sewers</b></p> <ul style="list-style-type: none"> <li>Sewerage Discharge Point/location of sewer connection</li> </ul>
Sanitary (Internal)	<p><b>Pre-consultation for Sanitary</b></p> <ul style="list-style-type: none"> <li>Used water discharge volume</li> </ul>
G1 Design Gateway	
Key Words	Requirement Category
ABC Waters	<p><b>ABC Waters Design Features</b></p> <p>To show conceptual plan endorsed by ABCWP (landscape Architect) or ABCWP (Architect) which includes:</p> <ul style="list-style-type: none"> <li>Overall catchment plan (e.g., sub- catchment area, treatment area for proposed ABC Waters design features, land status and demarcation of site boundary, green buffer DR, RR etc.)</li> <li>Overall layout plan (e.g., location of proposed ABC Waters features (indicative location of overflow sump within the feature), how it links with the proposed and existing drainage infra i.e., location of inlet and discharge point)</li> <li>Detention volume to be provided by proposed ABC Waters design features to satisfy requirements as stipulated in 7.1.5 of the Code of Practice on Surface Water Drainage (if any)*</li> </ul>
Detention System SPACE	<p><b>Peak Run Off</b></p> <ul style="list-style-type: none"> <li>Key Objective: To demonstrate how this is catered for, area is set aside for detention tank provision, location, OR drain widening</li> <li>Calculation of peak run off factor (C value) max. 0.55 (based on code and chart) e.g. area of development of greenfield site</li> </ul>
Infra & Utilities (Internal) SPACE	<p><b>Drainage Network</b></p> <ul style="list-style-type: none"> <li>To show conceptual plan – location, proposed discharged point, connection to existing drainage network</li> </ul> <p><b>Basement pumped drainage system (stormwater tank)</b></p> <ul style="list-style-type: none"> <li>Location, volume</li> </ul> <p><b>Critical Infrastructure/Key Installation</b></p> <ul style="list-style-type: none"> <li>To show location of Distribution Sub-Station</li> </ul>

For PUB's External Works requirements, please refer to [Page 173](#).

# Section 3: Specific Requirements by Regulatory Agencies

## Public Utilities Board (PUB)

INTRODUCTION TO CX

GENERAL REQUIREMENTS

• **REGULATORY AGENCIES** •

• KEY GATEWAYS •

• OTHER BUILDING WORKS •

BIM DATA REPRESENTATION



# Public Utilities Board (PUB)

Legend: ■ Architecture ■ C&S ■ M&E

G1 Design Gateway <i>(continued from previous page)</i>	
Key Words	Requirement Category
Platform & Crest Level, Earthworks / Topography SPACE	<b><u>Minimum Platform Level and Crest Level</u></b> <ul style="list-style-type: none"> <li>SHD</li> <li>Adjacent Road Levels</li> </ul>
	<b><u>Earthworks</u></b> <ul style="list-style-type: none"> <li>Minimum Platform Level / Changes to Topography</li> </ul>
	<b><u>Flood Protection Measures</u></b> <ul style="list-style-type: none"> <li>If crest level is not provided – location and height of protection measure</li> </ul>
Public Drains (Internal) SYSTEM Civil Element	<b><u>Common Drain</u></b> (Drains receiving upstream run off / existing [note: more common for landed housing area]) <ul style="list-style-type: none"> <li>Location, width</li> </ul>
	<b><u>Internal Drain</u></b> <ul style="list-style-type: none"> <li>Location, width</li> <li>Discharge point</li> </ul>
Public Sewerage System (External) SYSTEM DISTRIBUTION CHAMBER	<b><u>Sewer Connection</u></b> <ul style="list-style-type: none"> <li>Connection Point – where the proposed location is</li> </ul>
	<b><u>Sewerage System</u></b> <ul style="list-style-type: none"> <li>Alignment, Dimensions, Gradient, Calculation of new public Sewers</li> <li>Alignment, size, setback, Invert Level, Top Level of existing public Sewers.</li> <li>Location, Top Level, Invert Level, Manhole ID of connecting Manhole</li> <li>Location of Hydraulic/Vortex Drop</li> </ul>
Sanitary (Internal) DISTRIBUTION CHAMBER SANITARY APPLIANCES SYSTEM	<b><u>Indicative Location(s) of Drain-line and Inspection Chamber</u></b> <ul style="list-style-type: none"> <li>Location, Top Level and Invert Level of last Inspection Chamber.</li> <li>Location and Top level of remaining Inspection Chambers.</li> <li>Details (e.g. alignment) and Invert Level of Drain-line to be provided by M&amp;E in Construction Gateway (G2)</li> </ul>
	<b><u>Used Water Flow Rate</u></b> <ul style="list-style-type: none"> <li>Key Objective: To check that sewer can contain this flow</li> <li>Quantity &amp; flow rate expected to be discharged from development, where it is to be discharged (based on no. of toilets, shower head, etc. - in relation to no. of DUs)</li> </ul>
Site Layout, Drainage Reserve	<b><u>Drainage Reserve</u></b> <ul style="list-style-type: none"> <li>Location (align to DIP), width</li> </ul> <p>Note: Coordinated by the Architect, with inputs from C&amp;S</p>

For PUB's External Works requirements, please refer to [Page 173](#).

# Section 3: Specific Requirements by Regulatory Agencies

## Public Utilities Board (PUB)

INTRODUCTION TO CX

GENERAL REQUIREMENTS

• **REGULATORY AGENCIES** •

• KEY GATEWAYS •

• OTHER BUILDING WORKS •

BIM DATA REPRESENTATION



## Public Utilities Board (PUB)

Legend: ■ Architecture ■ C&S ■ M&E

G2 Construction Gateway	
Key Words	Requirement Category
ABC Waters	<p><b>ABC Waters Design Features</b></p> <p>For systems that include ABC Waters design features for peak runoff management, the detailed design, including detention volume to be provided, as endorsed by the ABC Waters Professional (who is also a PE(Civil)) shall be submitted</p>
Earthworks	<ul style="list-style-type: none"> <li>Slope calculation report</li> </ul>
<p>Infra &amp; Utilities (Internal)</p> <div style="display: flex; flex-wrap: wrap; gap: 10px;"> <div style="border: 1px solid gray; border-radius: 10px; padding: 2px 5px; font-size: 8px;">DISTRIBUTION CHAMBER</div> <div style="border: 1px solid gray; border-radius: 10px; padding: 2px 5px; font-size: 8px;">WASTE TERMINAL</div> <div style="border: 1px solid gray; border-radius: 10px; padding: 2px 5px; font-size: 8px;">INTERCEPTOR</div> <div style="border: 1px solid gray; border-radius: 10px; padding: 2px 5px; font-size: 8px;">VALVE</div> <div style="border: 1px solid gray; border-radius: 10px; padding: 2px 5px; font-size: 8px;">SYSTEM</div> <div style="border: 1px solid gray; border-radius: 10px; padding: 2px 5px; font-size: 8px;">PUMP</div> <div style="border: 1px solid gray; border-radius: 10px; padding: 2px 5px; font-size: 8px;">TANK (STORAGE)</div> </div>	<p><b>Sanitary Network</b></p> <ul style="list-style-type: none"> <li>Drain-lines, Inspection Chamber, Discharge Lines, etc.</li> <li>Sanitary Stack System</li> </ul> <p><b>Basement Pumped System</b></p> <ul style="list-style-type: none"> <li>May model a box as a placement holder. Details is to be drawn by Specialised PE</li> <li>Retention Tank</li> <li>RC Trench</li> </ul> <p><b>Sewer Network</b></p> <ul style="list-style-type: none"> <li>Minor Sewer (when applicable)</li> </ul> <p><b>Drainage Network</b></p> <ul style="list-style-type: none"> <li>C&amp;S: Effective tank capacity and other hydraulic details associated with the tank</li> <li>M&amp;E: For pumped detention tank, M&amp;E to provide pump details</li> </ul> <p><b>Proposed Treatment of Common Drain</b></p> <ul style="list-style-type: none"> <li>Longitudinal / sectional profile</li> <li>Side gates</li> </ul>

- Independent Submissions	
Key Words	Requirement Category
Water Supply	<ul style="list-style-type: none"> <li>Site plans, water reticulation schematic / layout drawing of WSI design works and water requirements</li> <li>Specified activities within water pipe corridor</li> </ul>
Public Drains (External)	<ul style="list-style-type: none"> <li>Earth Control Measures (ECM) Plan</li> <li>Details of temporary works affecting drainage / within drainage reserve</li> </ul>
Public Sewerage System (External)	<ul style="list-style-type: none"> <li>Details and scope of works on manholes and sewers</li> <li>Specified activities within sewer corridor</li> </ul>

----- End of Requirements for PUB -----

Click below for PUB's RABW Requirements for :

[External Works](#)



# Singapore Civil Defence Force (SCDF)

Legend:  Architecture  C&S  M&E IFC COMPONENT

G1 Design Gateway	
Key Words	Requirement Category
<p>Fire Engine Accessway / Access Road</p> <div style="display: flex; justify-content: space-around; align-items: center;"> <div style="border: 1px solid gray; border-radius: 10px; padding: 2px 5px; background-color: #f2f2f2;">ROAD</div> <div style="border: 1px solid gray; border-radius: 10px; padding: 2px 5px; background-color: #f2f2f2;">SITE BOUNDARY</div> </div> <div style="display: flex; justify-content: space-around; align-items: center; margin-top: 5px;"> <div style="border: 1px solid gray; border-radius: 10px; padding: 2px 5px; background-color: #f2f2f2;">SPACE</div> </div> <div style="display: flex; justify-content: space-around; align-items: center; margin-top: 5px;"> <div style="border: 1px solid gray; border-radius: 10px; padding: 2px 5px; background-color: #f2f2f2;">WINDOW</div> </div>	<p><b>Fire Engine Accessways / Access Road</b></p> <ul style="list-style-type: none"> <li>To design upfront and not added as an afterthought</li> <li>Compliance of provision of fire engine accessway / access road does not affect the requisite planting areas and roadside green verges</li> <li>Indication of all the fire engine access road and accessway within project boundary</li> <li>Clearly indicate if public road is used as fire engine accessway / access road</li> <li>Compliance of width of fire engine accessway</li> <li>Compliance of distance between fire engine accessway and fire access opening</li> <li>Compliance of no obstruction between fire engine accessway and fire access opening</li> </ul>

Note: QP has to ensure the above requirements for fire engine access shall not have any conflict with NPark requirements. Detailed checks of fire engine access requirements will be done at Construction Gateway

G2 Construction Gateway	
Key Words	Requirement Category
<p>General</p>	<p>QP to indicate clearly the following in the model:</p> <ul style="list-style-type: none"> <li>The usage in accordance with SpaceName in IfcSpaceValues. Xlsx (column M) worksheet. The SpaceName shall be tagged to the correct OccupancyType. QP should choose the specified OccupancyType if available. If a specified OccupancyType is not available, modeler can then choose OccupancyType = "Any" and choose any OccupancyType from the table.</li> <li>Egress Indicator Box (EIB) which indicate the width of exit/ exit access doors shall be tagged to all exit &amp; exit access doors that are serving as means of escape. EIB shall be indicated at the correct side of exit &amp; exit access door and shall exclude door leaf that is bolted.</li> <li>The storey name of each storey, including basement (in accordance with Fire Code definition of a basement).</li> <li>The property name "DischargePoint" has to tag to IfcDoor/IfcOpeningElement/IfcBuildingElementProxy.USERDEFINED.EXITPOINT when they are designated as discharge point at discharge level</li> <li>FireExit for door/opening that opens directly into exit staircase/exit passageaway and door/opening that opens directly to external at discharge level.</li> <li>The fire rating/non-combustible property of material.</li> <li>The % of porosity of awning, trellis, screen, roof, etc</li> </ul> <p>QP to submit the following when submitting the model:</p> <ul style="list-style-type: none"> <li>Calculation to show the compliance of occupant load and exit capacity for every storey/level for PG 2 to 8 projects.</li> <li>Elevation plans to indicate the unprotected openings for calculation of setback distance.</li> <li>Calculation to show the compliance of perimeter required for fire engine accessway</li> <li>2-D plans to show the design tonnage and material of fire engine accessway</li> <li>2-D plans to show clearly the designs of ventilation openings and the calculated % of ventilation (e.g. staircase ventilation, smoke free lobby ventilation, cross-ventilation corridor 50% ventilation).</li> </ul> <p>QP shall submit 2D plan if the requirements cannot be shown in the 3D model.</p>
<p>Emergency Voice Communication System</p> <div style="border: 1px solid gray; border-radius: 10px; padding: 2px 5px; background-color: #f2f2f2; margin-top: 5px;">SPACE</div>	<p><b>Emergency Voice Communication System and Fire Command Centre</b></p> <ul style="list-style-type: none"> <li>Declaration of one-way / two-way emergency voice communication system for the functional space</li> </ul>

# Section 3: Specific Requirements by Regulatory Agencies

## Singapore Civil Defence Force (SCDF)

INTRODUCTION TO CX

GENERAL REQUIREMENTS

• **REGULATORY AGENCIES** •

• KEY GATEWAYS •

• OTHER BUILDING WORKS •

BIM DATA REPRESENTATION



# Singapore Civil Defence Force (SCDF)

Legend:



Architecture



C&S



M&E

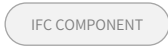

G2 Construction Gateway	
Key Words	Requirement Category
Exit STAIRCASE SPACE	<p><b>Means of Escape</b></p> <ul style="list-style-type: none"> <li>Compliance of adequate means of escape:                             <ul style="list-style-type: none"> <li>Adequate provision of exit staircase, exit door &amp; exit access door</li> <li>Capacity of exits and occupant load calculation</li> <li>Requirements of Internal &amp; external exit staircase</li> <li>Remoteness of exit</li> <li>Travel distance</li> <li>Smoke-free approach to exit staircase</li> <li>Discharge of exit staircase</li> <li>Ventilation of exits</li> <li>Staircase re-entry</li> </ul> </li> <li>Compliance of special requirements for Person With Disabilities (PWDs):                             <ul style="list-style-type: none"> <li>Provision of PWD holding point unless otherwise exempted</li> <li>Siting of PWD holding point</li> <li>Protection of PWD holding point</li> </ul> </li> </ul>
Exit sign and Emergency Lighting SECURITY LIGHTING SIGNAGE	<p><b>Exit Sign (incl. low level signs), Emergency Lighting, Photoluminescent Lighting</b></p> <p>Types of buildings / areas, and locations which require exit sign, photoluminescent lighting &amp; emergency lighting</p>
Fire Alarm System FIRE ALARM BREECHING INLET LANDING VALVE SYSTEM SPACE	<p><b>Automatic Fire Alarm (Heat / Smoke Detector)</b></p> <ul style="list-style-type: none"> <li>Types of buildings / usage which require provision of automatic fire alarm</li> <li>Types of buildings/ usage exempt from provision of automatic fire alarm</li> <li>QP to declare automatic fire alarm system is provided for the functional space</li> </ul> <p><u>Components to be indicated:</u></p> <ul style="list-style-type: none"> <li>Fire Alarm Panel</li> </ul> <p><b>Combined Sprinkler and Wet Riser System</b></p> <ul style="list-style-type: none"> <li>Types of buildings / areas which are allowed combined sprinkler and wet riser system</li> <li>QP to declare combined sprinkler and wet riser system is provided for the functional space</li> </ul> <p><u>Components to be modelled:</u></p> <ul style="list-style-type: none"> <li>Location of Sprinkler Control Valve</li> <li>Breeching Inlet (2-way or 4-way)</li> <li>Landing Valve</li> <li>Fire alarm panel</li> </ul> <p><b>Home Fire Alarm Device (HFAD)</b></p> <ul style="list-style-type: none"> <li>Types of buildings which require HFAD</li> <li>QP to declare Home Fire Alarm Device is provided for the functional space</li> <li>Compliance of location and number of HFAD points</li> </ul>





# Singapore Civil Defence Force (SCDF)



Legend:  Architecture  C&S  M&E IFC COMPONENT

G2 Construction Gateway	
Key Words	Requirement Category
<p>Fire Alarm System</p> <p><i>(continued from previous page)</i></p>	<p><b><u>Manual Alarm System</u></b></p> <ul style="list-style-type: none"> <li>Types of building / usage require manual call points</li> <li>QP to declare manual alarm system is provided for the functional space</li> </ul> <p><u>Components to be modelled:</u></p> <ul style="list-style-type: none"> <li>Manual alarm call points</li> <li>Fire alarm sounder</li> <li>Visual alarm device</li> <li>Fire alarm panel</li> </ul> <hr/> <p><b><u>Sprinkler System</u></b></p> <ul style="list-style-type: none"> <li>Types of buildings / usage require sprinkler system</li> <li>Types of buildings / usage exempt from provision of sprinkler system</li> <li>Provision of sprinklers for basement and aboveground buildings</li> <li>QP to declare sprinkler system is provided for the functional space</li> </ul> <p><u>Components to be modelled:</u></p> <ul style="list-style-type: none"> <li>Location of sprinkler control valve</li> <li>Breeching inlet (2-way or 4-way)</li> <li>Fire alarm panel</li> </ul> <hr/> <p><b><u>Video Image Fire Detection System (VIFDS)</u></b></p> <ul style="list-style-type: none"> <li>Types of buildings require VIFDS</li> <li>QP to declare video image fire detection system is provided for the functional space</li> </ul> <p><b><u>Automatic fire extinguishing system</u></b></p> <ul style="list-style-type: none"> <li>Rooms which allowed the use of automatic fire extinguishing system to replace automatic sprinkler</li> <li>QP to declare automatic fire extinguishing system is provided for the functional space</li> </ul> <hr/> <p><b><u>Water Mist System</u></b></p> <ul style="list-style-type: none"> <li>Compliance of requirements for water mist system as a substitute of sprinkler system</li> <li>QP to declare water mist system is provided for the functional space</li> </ul>
<p>Fire Lift</p>	<p><b><u>Fire Lift</u></b></p> <ul style="list-style-type: none"> <li>Compliance of buildings (other than PG 1 &amp; 2) provided with at least two fire lifts on every storey when habitable height exceeds 24m</li> <li>Basement exceeding 9m shall be provided with at least 2 fire lifts (other than PG 1)</li> <li>Compliance of one fire lift for PG 2 buildings exceeding 24m.</li> <li>Compliance of two fire lifts for PG 2 super hig-rise building exceeding 40 storeys.                             <ul style="list-style-type: none"> <li>Compliance of fire resistance rating for lift shaft</li> <li>Fire lift to serve continuous throughout the building, including basements</li> <li>Distance between fire lift landing door and exit staircase not exceeding 5m &amp; 10m (applicable to PG 2 discharge floor only)</li> <li>Fire lift to be accessible to any part of the storey</li> <li>60m coverage for fire lift (except PG 1 &amp; 2)</li> </ul> </li> </ul>



# Singapore Civil Defence Force (SCDF)

Legend:  Architecture  C&S  M&E IFC COMPONENT

G2	Construction Gateway	
Key Words	Requirement Category	
<p>Firefighting System</p> <div style="margin-top: 5px;"> <div style="border: 1px solid #ccc; border-radius: 10px; padding: 2px 10px; display: inline-block; margin-bottom: 5px;">LIFT</div> <div style="border: 1px solid #ccc; border-radius: 10px; padding: 2px 10px; display: inline-block; margin-bottom: 5px; margin-left: 10px;">FIRE HYDRANT</div> <div style="border: 1px solid #ccc; border-radius: 10px; padding: 2px 10px; display: inline-block; margin-bottom: 5px; margin-left: 10px;">HOSEREEL</div> <div style="border: 1px solid #ccc; border-radius: 10px; padding: 2px 10px; display: inline-block; margin-bottom: 5px; margin-left: 10px;">BREECHING INLET</div> <div style="border: 1px solid #ccc; border-radius: 10px; padding: 2px 10px; display: inline-block; margin-bottom: 5px; margin-left: 10px;">LANDING VALVE</div> <div style="border: 1px solid #ccc; border-radius: 10px; padding: 2px 10px; display: inline-block; margin-bottom: 5px; margin-left: 10px;">FIRE EXTINGUISHER</div> <div style="border: 1px solid #ccc; border-radius: 10px; padding: 2px 10px; display: inline-block; margin-bottom: 5px; margin-left: 10px;">SYSTEM</div> <div style="border: 1px solid #ccc; border-radius: 10px; padding: 2px 10px; display: inline-block; margin-left: 10px;">SPACE</div> </div>	<p><b>Evacuation Lift</b></p> <ul style="list-style-type: none"> <li>• Evacuation lift for evacuation of occupants to be modelled for building with habitable height exceeding 24m (except PG I &amp; II):                             <ul style="list-style-type: none"> <li>○ Can double-up as PWD evacuation lift</li> <li>○ One of fire lifts can be used as evacuation lift</li> <li>○ Provision of means of communications &amp; CCTVs</li> <li>○ Provision of evacuation switch</li> </ul> </li> </ul>	<ul style="list-style-type: none"> <li>• Evacuation lift for evacuation of PWD to be modelled for buildings more than 4 storey:                             <ul style="list-style-type: none"> <li>○ At least one evacuation lift required, passenger lift can be used as evacuation lift</li> <li>○ Provision of protected lobby</li> </ul> </li> </ul>
	<p><b>Fire Lift</b></p> <p>Compliance of buildings (other than PG I &amp; II) provided with at least two fire lifts on every storey</p> <ul style="list-style-type: none"> <li>○ When habitable height exceeds 24m</li> <li>○ When depth of basement exceeds 9m</li> <li>• Compliance of two fire lifts for super high-rise (above 40 storeys) residential building</li> <li>• Compliance of fire resistance rating of lift shaft</li> <li>• Fire lift to serve continuously throughout the building, including basements</li> <li>• Distance between fire lift landing door and exit staircase shall not exceeding 5m &amp; 10m (10m is applicable to PG 2 discharge floor only)</li> <li>• Fire lift to be accessible to every part of the storey</li> <li>• Compliance of 60m coverage for fire lift (except PG I &amp; II)</li> </ul>	
	<p><b>Fire Hydrant</b></p> <ul style="list-style-type: none"> <li>• Indication of private and public hydrant serving the project</li> <li>• Hydrant coverage not more than 50m from the fire engine accessway / access road</li> </ul> <p><u>Components to be modelled</u></p> <ul style="list-style-type: none"> <li>○ Full design of private/public hydrant, excluding underground piping.</li> </ul>	
	<p><b>Hose Reel</b></p> <ul style="list-style-type: none"> <li>• Compliance of provision of hose reel</li> <li>• Number of hose reel</li> <li>• Coverage of hose reel (30m+6m)</li> <li>• Types of buildings / areas require provision of hose reel</li> <li>• Types of buildings / areas exempt from provision of hose reel</li> <li>• Siting of hose reel</li> </ul> <p><u>Components to be modelled</u></p> <ul style="list-style-type: none"> <li>• Hose reel cabinet/enclosure.</li> <li>• Hose reel drum with hose can be represented by object</li> <li>• Need not model the piping for hose reel</li> </ul>	<div style="display: flex; justify-content: space-around; align-items: center;"> <div style="text-align: center;">  <p>Private hydrant</p> </div> <div style="text-align: center;">  <p>Public hydrant</p> </div> </div>
	<p><b>Portable Fire Extinguisher</b></p> <ul style="list-style-type: none"> <li>• Types of buildings / areas require portable extinguisher</li> <li>• Types of buildings / areas exempt from provision of portable extinguisher</li> <li>• Siting of portable extinguisher</li> </ul>	



# Singapore Civil Defence Force (SCDF)

Legend:



Architecture



C&S



M&E

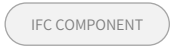

G2 Construction Gateway	
Key Words	Requirement Category
Firefighting System  <i>(continued from previous page)</i>	<p><b><u>Rising Mains and System</u></b></p> <ul style="list-style-type: none"> <li>Type of rising main provided (Dry or Wet)</li> <li>Number of rising main</li> <li>Siting and coverage of landing valve</li> </ul> <p><u>Components to be modelled for Dry and Wet Riser:</u></p> <ul style="list-style-type: none"> <li>Breeching inlet (to show 2-way or 4-way)</li> <li>Landing valve</li> <li>Wet riser tank (for wet riser only)</li> <li>Wet riser pump (for wet riser only)</li> </ul> <p><u>Provision of Standby Fire Hose:</u></p> <ul style="list-style-type: none"> <li>Types of buildings requiring standby fire hose</li> <li>Number of standby hose</li> <li>Located not more than 2m from landing valve</li> </ul> <p>Standby hose need not be modelled in full, the cabinet/enclosure for standby hose if provided shall be modelled in full.</p> <p><u>Provision of Breeching Inlet:</u></p> <ul style="list-style-type: none"> <li>Location</li> <li>Number</li> </ul>
Performance-Based project	<p><b>For projects with Performance-Based approach</b></p> <p> QP to submit 2-D plans clearly indicating the rooms/spaces to be approved in Performance-Based submission.</p> <p><b>Performance-Based (PB) Plan Approval Process</b></p> <ul style="list-style-type: none"> <li>For approval process, refer to <a href="https://www.scdf.gov.sg/home/fire-safety/plans-and-consultations/performance-based-approach-to-fire-safety-design/performance-based-plan-approval-process">https://www.scdf.gov.sg/home/fire-safety/plans-and-consultations/performance-based-approach-to-fire-safety-design/performance-based-plan-approval-process</a>.</li> <li>In general, FEDB IPA should be obtained before CG submission and FER should be submitted together with Building Plan during CG submission. This approach strives to minimise any major reworks in the later stages of development.</li> </ul> <p>For complex cases in which the FEDB IPA could not be obtained before CG submission, the CG submission may still proceed with the following conditions:</p> <ul style="list-style-type: none"> <li>While the CG submission may proceed concurrently with the FEDB review, the FEDB IPA will need to be obtained before issuance of CG clearance.</li> <li>If the project team is not ready with the FER during CG submission, the QP will need to exclude the affected PB fire safety works from the application and declare that no affected PB fire safety works would be carried out until FER approval is obtained. The FER should subsequently be submitted as an amendment to CG to obtain approval for the relevant PB fire safety works.</li> </ul>
Site Planning & External Firefighting Provisions  WINDOW  ROAD  SPACE  SIGNAGE	<p><b><u>Fire Access Opening</u></b></p> <ul style="list-style-type: none"> <li>Compliance of provision of fire access opening</li> <li>Location, signage &amp; size</li> <li>Number and position of access opening</li> <li>Exemption of fire access opening</li> </ul>



# Singapore Civil Defence Force (SCDF)

Legend:  Architecture  C&S  M&E IFC COMPONENT

G2 Construction Gateway	
Key Words	Requirement Category
<p>Site Planning &amp; External Firefighting Provisions</p> <p><i>(continued from previous page)</i></p> <p style="text-align: center;"> <span style="border: 1px solid gray; border-radius: 10px; padding: 2px 5px; margin: 2px;">WINDOW</span>  <span style="border: 1px solid gray; border-radius: 10px; padding: 2px 5px; margin: 2px;">ROAD</span>  <span style="border: 1px solid gray; border-radius: 10px; padding: 2px 5px; margin: 2px;">SPACE</span>  <span style="border: 1px solid gray; border-radius: 10px; padding: 2px 5px; margin: 2px;">SIGNAGE</span> </p>	<p><b><u>Fire Command Centre (FCC)</u></b></p> <ul style="list-style-type: none"> <li>• FCC shall be provided if building requires:                             <ul style="list-style-type: none"> <li>○ Fire lift</li> <li>○ Emergency voice communication system</li> <li>○ Engineered smoke control system</li> </ul> </li> <li>• Size and Location of FCC</li> <li>• Ventilation system for FCC</li> <li>• Supporting equipment allow in FCC</li> </ul> <hr/> <p><b><u>Fire Engine Accessway / Access Road</u></b></p> <ul style="list-style-type: none"> <li>• Compliance of fire engine access road requirements of PG I to VIII and mixed-use buildings:                             <ul style="list-style-type: none"> <li>○ Indicate road serving as fire engine access road within the project boundary. To indicate on plan if public road is used as fire engine access road.</li> <li>○ Compliance of width, turning radii/ facilities, design load capacity, gradient, overhead clearance.</li> <li>○ Marking and signpost along fire engine access road.</li> <li>○ Compliance of no obstruction along fire engine access road</li> <li>○ Basement: Compliance of fire engine access road within a travel distance of 18m to the entrance of all exit staircases where landing valves (dry or wet riser) are provided.</li> </ul> </li> <li>• Compliance of fire engine accessway requirements for PG II to VIII and mixed-use buildings:                             <ul style="list-style-type: none"> <li>○ Indicate road serving as fire engine accessway within the project boundary. To indicate on plan if public road is used as fire engine accessway.</li> <li>○ Compliance of width and length of fire engine accessway. To submit separate calculations for the required length of fire engine accessway</li> <li>○ Compliance of turning radii/ facilities, design load capacity, gradient, overhead clearance</li> <li>○ Marking and signpost along fire engine accessway</li> <li>○ Compliance of no obstruction along and above fire engine accessway</li> <li>○ Basement: Compliance of fire engine accessway within a travel distance of 18m to the entrance of all exit staircases where landing valves (dry or wet riser) are provided.</li> </ul> </li> </ul>
<p>Structural Fire Precautions</p> <p style="text-align: center;"> <span style="border: 1px solid gray; border-radius: 10px; padding: 2px 5px; margin: 2px;">DOOR</span>  <span style="border: 1px solid gray; border-radius: 10px; padding: 2px 5px; margin: 2px;">SLAB</span>  <span style="border: 1px solid gray; border-radius: 10px; padding: 2px 5px; margin: 2px;">WALL</span>  <span style="border: 1px solid gray; border-radius: 10px; padding: 2px 5px; margin: 2px;">LIFT</span>  <span style="border: 1px solid gray; border-radius: 10px; padding: 2px 5px; margin: 2px;">STAIRCASE</span>  <span style="border: 1px solid gray; border-radius: 10px; padding: 2px 5px; margin: 2px;">SPACE</span>  <span style="border: 1px solid gray; border-radius: 10px; padding: 2px 5px; margin: 2px;">DAMPER</span> </p>	<p><b><u>Compartmentation</u></b></p> <ul style="list-style-type: none"> <li>• Compliance of compartmentation requirements:                             <ul style="list-style-type: none"> <li>○ Area and cubical extent to comply with Table 3.2A (for buildings not protected with sprinkler system)</li> <li>○ Maximum of 3 storeys per compartment when habitable height is not exceeding 24m</li> <li>○ Maximum of 1 storey per compartment when habitable height exceeds 24m</li> </ul> </li> <li>• Compliance of compartmentation requirements for Atrium space</li> <li>• Compliance of compartmentation requirements for High hazard occupancy</li> <li>• Compliance of compartmentation requirements for basement</li> <li>• Exemption of size limitation of compartment for car park</li> <li>• Exemption of size limitation for buildings protected with sprinkler system</li> <li>• Compliance of area / room / usage requires compartmentation</li> </ul> <hr/> <p><b><u>Compartmentation Walls and Compartmentation Floors</u></b></p> <ul style="list-style-type: none"> <li>• Compliance of requirements for compartment walls or compartment floors:                             <ul style="list-style-type: none"> <li>○ Fire resistance rating</li> <li>○ Non-combustible</li> </ul> </li> <li>• Use of fire shutter as compartment wall</li> <li>• Room / space allows the use of fire rated roller shutter</li> </ul>



# Singapore Civil Defence Force (SCDF)

Legend:  Architecture  C&S  M&E IFC COMPONENT

G2 Construction Gateway	
Key Words	Requirement Category
<p>Structural Fire Precautions</p> <p><i>(continued from previous page)</i></p> <div style="display: flex; flex-direction: column; gap: 5px;"> <div style="border: 1px solid gray; border-radius: 10px; padding: 2px 10px; background-color: #eee;">DOOR</div> <div style="border: 1px solid gray; border-radius: 10px; padding: 2px 10px; background-color: #eee;">SLAB</div> <div style="border: 1px solid gray; border-radius: 10px; padding: 2px 10px; background-color: #eee;">WALL</div> <div style="border: 1px solid gray; border-radius: 10px; padding: 2px 10px; background-color: #eee;">LIFT</div> <div style="border: 1px solid gray; border-radius: 10px; padding: 2px 10px; background-color: #eee;">STAIRCASE</div> <div style="border: 1px solid gray; border-radius: 10px; padding: 2px 10px; background-color: #eee;">SPACE</div> <div style="border: 1px solid gray; border-radius: 10px; padding: 2px 10px; background-color: #eee;">DAMPER</div> </div>	<p><b><u>External Wall</u></b></p> <ul style="list-style-type: none"> <li>• Compliance of requirements for external walls                             <ul style="list-style-type: none"> <li>○ Fire resistance rating</li> <li>○ Non-combustible</li> </ul> </li> <li>• Compliance of setback distance for unprotected opening</li> <li>• Compliance of external wall finishes</li> <li>• Compliance of vertical fire spread requirements</li> <li>• Exemption of fire resistance rating for non-load-bearing external wall</li> </ul> <hr/> <p><b><u>Element of Structure</u></b></p> <ul style="list-style-type: none"> <li>• Compliance of element of structure requirements</li> <li>• Minimum periods of fire resistance in accordance with Table 3.3A</li> <li>• Exemption of fire resistance rating for single storey buildings</li> <li>• Compliance of requirements for the use of fire-rated board for protection to structural steel beams, columns</li> </ul> <hr/> <p><b><u>Protected Shafts</u></b></p> <ul style="list-style-type: none"> <li>• Compliance of services running inside and/or passing through fire lift lobby and smoke-free lobby</li> <li>• Compliance of gas pipe running inside an internal corridor / lobby</li> <li>• Prohibition of other services passing through FCC, fire pump room, emergency generator room &amp; smoke control fan room.</li> <li>• Compliance of requirements for protected shaft:                             <ul style="list-style-type: none"> <li>○ Fire resistance rating</li> <li>○ Non-combustible</li> <li>○ Material of construction</li> <li>○ Opening in protected shaft</li> <li>○ Ventilation</li> <li>○ Fire resistance rating of doors in protected shaft</li> </ul> </li> <li>• Compliance of protected shaft containing exit staircase:                             <ul style="list-style-type: none"> <li>○ Compartmentation of exit staircase with masonry or drywall construction</li> <li>○ Fire resistance of door opening into exit staircase</li> <li>○ Finishes within exit staircase shall be non-combustible</li> <li>○ Types of services allowed in exit staircase</li> </ul> </li> <li>• Compliance of requirements for lift shaft:                             <ul style="list-style-type: none"> <li>○ Material of construction</li> <li>○ Exemption of enclosure in protected shaft located at edge of atrium</li> <li>○ Provision of protected lobby when lift is at basement</li> <li>○ Compliance of requirements for private lift for exclusive use of occupants in residential under PG II</li> </ul> </li> <li>• Compliance of protected shaft containing other services installations:                             <ul style="list-style-type: none"> <li>○ Electrical conduits / cable tray</li> </ul> </li> </ul> <hr/> <p><b><u>Separating Walls</u></b></p> <ul style="list-style-type: none"> <li>• Exemption of separating wall requirements for PG I &amp; II buildings</li> <li>• Compliance of Openings in separating wall requirements</li> <li>• Compliance of requirements for separating walls                             <ul style="list-style-type: none"> <li>○ Fire resistance rating</li> <li>○ Non-combustible</li> </ul> </li> </ul>



# Singapore Civil Defence Force (SCDF)

Legend:  Architecture  C&S  M&E IFC COMPONENT

G2 Construction Gateway	
Key Words	Requirement Category
Structural Fire Precautions  <i>(continued from previous page)</i>	<p><b><u>Use of other fire rated material</u></b></p> <ul style="list-style-type: none"> <li>• Compliance of requirements on use of Fire rated board</li> <li>• Compliance of requirement on use of intumescent paint</li> <li>• Compliance of requirement on use of flame retardant chemicals</li> </ul>
Declarations	<p><b><u>Fire alarm &amp; protection system declaration</u></b></p> <p>QP to declare at those functional space which are provided with the following fire alarm &amp; protection System(s):</p> <ul style="list-style-type: none"> <li>• Manual alarm system</li> <li>• Automatic alarm system (heat or smoke)<sup>@</sup></li> <li>• Sprinkler system<sup>@</sup></li> <li>• Water mist system<sup>@</sup></li> <li>• Foam-water sprinkler<sup>@</sup></li> <li>• Home Fire Alarm Device</li> </ul> <p><i>@: Details to be provided and submitted by M&amp;E QP in Fire Protection (FP) Plan under Independent Submissions</i></p> <hr/> <p><b><u>Mechanical Ventilation System declaration</u></b></p> <p>QP to declare at those functional space which are provided with the following Ventilation System(s):</p> <ul style="list-style-type: none"> <li>• Natural ventilation (NV)</li> <li>• Mechanical ventilation (MV)*</li> <li>• Pressurisation*</li> <li>• Cross-ventilation</li> <li>• Cross-ventilation with intermediate - ventilation opening</li> <li>• Vapour extraction system (spray painting booth)</li> </ul> <p><i>*: Details to be provided and submitted by M&amp;E QP in Mechanical Ventilation (MV) plan under independent submissions.</i></p> <hr/> <p><b><u>Smoke Control System declaration</u></b></p> <p>QP to declare at those functional space which are provided with the following smoke control System(s):</p> <ul style="list-style-type: none"> <li>• Ductless Jet Fan System ^</li> <li>• Engineered Smoke Control System^</li> <li>• Smoke Purging System^</li> <li>• Smoke vent</li> </ul> <p><i>^: Details to be provided and submitted by M&amp;E QP in Mechanical Ventilation (MV) Plan under Independent Submissions.</i></p>
Others	<ul style="list-style-type: none"> <li>• QP shall refer to Chapter 9 for additional fire safety requirements for specific purpose groups and Chapter 10 for fire safety requirements for special installations.</li> </ul>



## Singapore Civil Defence Force (SCDF)

- Independent Submissions	
Key Words	Requirement Category
Mechanical Ventilation & Smoke Control System	<p><b>Air-Conditioning, Mechanical Ventilation and Fire Protection Plan (MV &amp; FP)</b></p> <ul style="list-style-type: none"> <li>Detailed layout and floor plan showing Fire Protection and Mechanical Ventilation system of development</li> <li>Key features of the building in which the system is to be installed</li> <li>Schematic diagram of the overall system showing clearly the key features and their functions, relative locations in the building, lots, sizes, capacities and other essential information incl. the air distribution design arrangement in the case of air-conditioning and mechanical ventilation systems</li> <li>Layout of the system on every floor plan showing clearly the various parts and their functions, locations, arrangements, sizes, capacities and other essential information</li> <li>Necessary cross-sectional views as superimposed on the building or part thereof to fully describe the details and configurations of the system</li> <li>A colour scheme to clearly distinguish the various distinct parts of the system and the different systems from one another</li> <li>Volumetric rate of flow of air at each point of inlet and outlet of each system including those serving protected staircases, exit passageways, lobbies, areas of refuge, the Fire Command Centre, fire pump rooms, generator rooms, rooms used for the storage of flammable liquids or gas or other areas of special risk;</li> <li>Location of:                             <ul style="list-style-type: none"> <li>Fire compartment walls, floors, air shafts, fire dampers, smoke detectors and other fire precautionary features</li> <li>Automatic Fire Alarm System</li> <li>Automatic Fire Extinguishing System</li> <li>Emergency Voice Communication System</li> <li>Smoke Control System</li> <li>Calculations and reports (where applicable)</li> </ul> </li> </ul>

G3 Completion Gateway	
Item for TOP / CSC	Requirement Category
-	<p><b>QP(s) shall certify that the fire safety works have been completed in accordance with the Code of Practice for Fire Precautions in Buildings, Fire Safety Act and its Regulations and relevant Codes of Practice and submit the following documents.</b></p> <ul style="list-style-type: none"> <li>Certification of Fire Safety Works</li> <li>RI Engagement Form</li> <li>Registered Inspector's Inspection Certificate (RI Form 1 or 2)</li> <li>RI Inspection Report</li> <li>RI Cessation form, where applicable</li> <li>Declaration of Regulated Fire Safety Products, where applicable</li> <li>CoC for Regulated Fire Safety Products, where applicable</li> <li>Delivery Orders for Regulated Fire Safety Products, where applicable</li> <li>FSC02 - Certification for Regulated Fire Safety Products, where applicable</li> <li>FSC03 - Certification for Lift Installation &amp; Operation, where applicable</li> <li>FSC04 - Certification for Fire Engine Access Road And Accessway, where applicable</li> </ul>

----- **End of Requirements for SCDF** -----



# Urban Redevelopment Authority (URA)

Legend:  Architecture  C&S  M&E IFC COMPONENT

- Pre-Submission, Planning and Other Consultations	
Key Words	Requirement Category
Conservation	<a href="#">Refer to URA Conservation Requirements here</a>
Impact Studies only	<div style="display: flex; align-items: flex-start;"> <div style="margin-right: 10px;"> </div> <div> <p><b>Environmental Impact Assessment (where required)</b></p> <ul style="list-style-type: none"> <li>If development projects are near to sensitive areas (such as Nature Reserves, Nature Areas, marine and coastal areas, other areas of significant biodiversity) or might have potential trans-boundary impacts, relevant technical agencies (such as the National Parks Board, National Environment Agency, Maritime and Port Authority of Singapore, and Singapore Food Agency) will need to be consulted more extensively to determine if a more thorough environmental study is required.</li> <li>For affected proposals, URA will provide project teams with further instructions on how to proceed with such consultations</li> </ul> </div> </div>
	<div style="display: flex; align-items: flex-start;"> <div style="margin-right: 10px;"> </div> <div> <p><b>Outline Application / Rezoning</b></p> <p>Where there are deviations to Master Plan parameters (e.g. land use, GPR, height, etc), the project team should submit an outline application prior to making the Design Gateway submission, with the following details/information:</p> <ul style="list-style-type: none"> <li>Planning proposal data (e.g. site area, GFA and use breakdown, numbers of units/rooms, etc.)</li> <li>Site layout plan and form/massing schemes, where necessary</li> <li>Any other studies or reports to illustrate the feasibility of the proposal, where necessary</li> </ul> </div> </div>
Site Layout only	<div style="display: flex; align-items: flex-start;"> <div style="margin-right: 10px;"> </div> <div> <p><b>Pre-Application Consultation Service</b></p> <ul style="list-style-type: none"> <li>Details of proposals to clarify or seek deviation from specific guidelines</li> </ul> <p>[Note: This is a chargeable service which will allow QPs to discuss proposals that may depart from the usual guidelines and address certain planning issues upfront. To access this service, please make an application through URA’s website - <a href="https://www.ura.gov.sg/pacsWeb/">https://www.ura.gov.sg/pacsWeb/</a>]</p> </div> </div>
	<p>Please note that the PCP process will differ for submissions made through CORENET X</p> <p><b>Non-Government Land Sale (GLS) Sites</b></p> <ul style="list-style-type: none"> <li>If a Public Communications Plan is required, it will be made known at Design Gateway submission, where URA will provide guidance on the follow up distribution of flyers to the local community and submission of relevant forms.</li> </ul> <p><b>GLS Sites</b></p> <ul style="list-style-type: none"> <li>Public Communications Plan requirements, if any, will be clearly set out in the tender conditions. For projects that are submitted to CORENET X, the Developer/QPs can reach out to the relevant Sales Agent</li> </ul>
Public Communications Plan (PCP)	
Others	<div style="display: flex; align-items: flex-start;"> <div style="margin-right: 10px;"> </div> <div> <p><b>Built Environment Transformation Bonus GFA Incentive</b></p> <ul style="list-style-type: none"> <li>Submission of incentive scheme application and supporting documents</li> </ul> </div> </div>





# Urban Redevelopment Authority (URA)

Legend:



Architecture



C&S



M&E

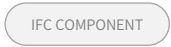

- Pre-Submission, Planning and Other Consultations	
Key Words	Requirement Category
Others	<p><b><u>Pre-DG Submission: Stage 1 Design Advisory Panel – for selected projects</u></b></p> <ul style="list-style-type: none"> <li>The DAP materials submitted are to consist of:                             <ul style="list-style-type: none"> <li>Technical drawings (including a full set of plans, elevations and sections)</li> <li>Digital and hardcopy DAP booklets (including 2 hardcopies in A3), which should not exceed 50 pages, including appendices, attached drawings and plans, with a minimum font size of 12.</li> <li>Presentation slides. The number of presentation slides should be comfortable for a 20-minute presentation without lengthy text, highlighting the key points with further elaboration provided in the DAP booklet.</li> <li>Digital models</li> <li>Where necessary, a physical model of the proposed development will be required, at scale of 1:400 or smaller (to be advised by the officer in charge), showing context of site] will have to be submitted.</li> <li>Additional reports, such as Conservation Reports, are to be included as Appendices to the A3 booklets.</li> </ul> </li> <li>The following aspects of the proposal will be assessed at this stage of the DAP:                             <ul style="list-style-type: none"> <li><u>Stage 1 (Pre-DG DAP)</u> <ul style="list-style-type: none"> <li>Design Philosophy / Concept</li> <li>Form and Massing</li> <li>General architectural treatment (roofscape, façade in relation to context)</li> <li>Pedestrian Network and Vehicular Access</li> <li>Public Spaces and Landscape Replacement Areas / landscaping concepts</li> </ul> </li> </ul> </li> </ul>

G1 Design Gateway	
Key Words	Requirement Category
Access to Site ROAD SLAB	<p><b><u>Site Layout</u></b></p> <ul style="list-style-type: none"> <li>Indicative locations of Pedestrian, Cycling, Vehicular and Service Access</li> </ul>
Building Massing BUILDING STOREY SPACE	<p><b><u>Building Form and Massing</u></b></p> <ul style="list-style-type: none"> <li>Development Statement of Intent (DSI) – Response to site context</li> <li>Façade articulation and urban veranda (Orchard Road only)</li> </ul>
	<p><b><u>Building Height</u></b></p> <ul style="list-style-type: none"> <li>Floor-to-Floor Height &amp; Aggregate Building Height                             <ul style="list-style-type: none"> <li>Number of Storeys</li> <li>Additional Height for Predominant Sky Terrace Storey</li> </ul> </li> <li>Overall Building Height Control (incl. building crown and M&amp;E floor, if any)</li> </ul>
	<p><b><u>Building Edge</u></b></p> <ul style="list-style-type: none"> <li>Alignment of building edge and percentage of building form articulation</li> <li>Height of building edge</li> <li>Depth of building edge</li> </ul>

# Section 3: Specific Requirements by Regulatory Agencies

## Urban Redevelopment Authority (URA)

INTRODUCTION TO CX

GENERAL REQUIREMENTS

• **REGULATORY AGENCIES** •

• KEY GATEWAYS •

• OTHER BUILDING WORKS •

BIM DATA REPRESENTATION



# Urban Redevelopment Authority (URA)

Legend:



Architecture



C&S



M&E

IFC COMPONENT

G1 Design Gateway	
Key Words	Requirement Category
<p>Connectivity</p> <p>SPACE RAMP</p> <p>PARKING LOT SITE BOUNDARY</p>	<p><b><u>Pedestrian Network</u></b></p> <p>Through Block Link (TBL), Underground Pedestrian Link(UPL), Elevated Pedestrian Link (EPL), Covered Walkways (CW), Open Walkways (OW), Covered Linkways (CL), High Covered Linkways (HCL)</p> <ul style="list-style-type: none"> <li>Layout and connections to existing / future developments</li> <li>Alignment to adjacent pedestrian connections</li> <li>Proposed levels and mitigation of level differences (if any)</li> <li>Soffit height, overall width and clear width</li> <li>Vehicular ramps to start after these Pedestrian Networks</li> </ul> <p>Additional requirements for the following:</p> <ul style="list-style-type: none"> <li>(UPL, EPL) Detailed layout of vertical circulation point – location within development, and dimensions</li> <li>(UPL, EPL) Knock Out Panels (KOP) details (e.g. alignment, size) where relevant</li> </ul> <p><b><u>Walking and Cycling Plan</u></b></p> <ul style="list-style-type: none"> <li>Connectivity to transport node</li> <li>Provision of measures to prevent conflict between pedestrian, cyclists and motor vehicles</li> <li>Provision of bicycle parking and supporting amenities (i.e. shower facilities and lockers)</li> </ul>
<p>Common Services Tunnel (CST)</p>	<p><b><u>CST Integration</u></b></p> <ul style="list-style-type: none"> <li>Integration of CST ancillary structures such as ventilation shaft, entrance, exit &amp; any space dedicated to CST functions – Assessment of proposed layout and alignment.</li> <li>Link Chamber to CST junction box – Assessment of proposed layout of link chamber with the type of services shown.</li> <li>CST manholes or installation mouths –Assessment of proposed layout and alignment</li> </ul>
<p>Conservation</p>	<p><a href="#">Refer to URA Conservation Requirements here</a></p>
<p>Earthworks / Topography</p> <p>WALL EARTHWORKS</p>	<p><b><u>Earthworks, Retaining Walls and Boundary Walls</u></b></p> <ul style="list-style-type: none"> <li>Height of retaining wall(s), extent of earth-fill and impact on surroundings where relevant</li> </ul> <p><b><u>Earthworks, Platform Level</u></b></p> <ul style="list-style-type: none"> <li>Minimum Platform Level / Changes to site topography</li> </ul>
<p>External Works</p> <p>SPACE</p>	<p><b><u>Linkway Connection to Commuter Facilities</u></b></p> <ul style="list-style-type: none"> <li>Indicative alignment</li> <li>Connection through existing / future development</li> <li>Soffit height, overall width and clear width</li> <li>Proposed levels and mitigation of level differences (if any)</li> </ul> <p><b><u>Cycling Path</u></b></p> <ul style="list-style-type: none"> <li>Provision according to safeguarded cycling plan</li> <li>Indicative location of bicycle parking and supporting amenities (i.e. shower facilities and lockers) and declared GFA</li> </ul> <p><b><u>Promenade Guidelines (UD requirements for Singapore River)</u></b></p> <ul style="list-style-type: none"> <li>Location of walkways and landscaping</li> </ul>



# Urban Redevelopment Authority (URA)

Legend:  Architecture  C&S  M&E IFC COMPONENT

G1 Design Gateway <i>(continued from previous page)</i>	
Key Words	Requirement Category
Greenery <div style="display: flex; justify-content: space-around; margin-top: 5px;"> <div style="border: 1px solid gray; border-radius: 10px; padding: 2px 5px; background-color: #eee;">PLANTING AREA</div> <div style="border: 1px solid gray; border-radius: 10px; padding: 2px 5px; background-color: #eee;">PLANTER BOX</div> </div> <div style="margin-top: 5px;"> <div style="border: 1px solid gray; border-radius: 10px; padding: 2px 5px; background-color: #eee; width: 50px; margin: 0 auto;">SPACE</div> </div>	<p><b><u>Landscape Provision</u></b></p> <ul style="list-style-type: none"> <li>Landscape Replacement Area (LRA) requirements : There is no need to provide details of LRA computation in the Design Gateway plans/models. QPs should factor in the LRA requirements as part of their design at the onset and provide the details that will be checked at Construction Gateway</li> <li>Landscape Provision: Indicative Extent</li> <li>Indicative location of Sky Terrace / Planter Boxes / Covered Communal Ground Garden / Communal Pavilions</li> </ul>
Infra & Utilities (Internal) only	<p><b><u>Urban Design Requirements</u></b></p> <ul style="list-style-type: none"> <li>Integration of Utilities (e.g. MRT pop-up, substation, water bulk meter) into building envelope</li> </ul>
Loading / Development Loading <div style="margin-top: 5px;"> <div style="border: 1px solid gray; border-radius: 10px; padding: 2px 5px; background-color: #eee; width: 50px; margin: 0 auto;">SPACE</div> </div>	<p><b><u>Loading Provisions</u></b></p> <ul style="list-style-type: none"> <li>Alignment and locations of loading columns</li> <li>Structural system and integration with future structures (e.g. location / orientation / size of vents)</li> <li>Loading calculations</li> <li>(EPL) Loading provision to receive future linkways / walkways (if any)</li> </ul> <p><b><u>Supporting Documents:</u></b></p> <div style="margin-left: 20px;"> <ul style="list-style-type: none"> <li><input checked="" type="checkbox"/> a) Draft Development Interface Report for future developer</li> <li><input checked="" type="checkbox"/> b) Clearance from technical agencies</li> </ul> </div>
Night Lighting	<p><b><u>Night Lighting Report</u></b></p> <div style="margin-left: 20px;"> <ul style="list-style-type: none"> <li><input checked="" type="checkbox"/> UD Areas with night lighting requirement</li> <li><input checked="" type="checkbox"/> Concept and renders, Location and Extent</li> </ul> </div>
ORA / ODA / Kiosks	<ul style="list-style-type: none"> <li>Location and extent, key parameters (e.g. structure, height, transparency)</li> </ul>
Public Space <div style="margin-top: 5px;"> <div style="border: 1px solid gray; border-radius: 10px; padding: 2px 5px; background-color: #eee; width: 50px; margin: 0 auto;">SPACE</div> </div>	<p><b><u>Privately-Owned Public Spaces (POPS)</u></b></p> <ul style="list-style-type: none"> <li>Indicate location, design and dimensions:                             <ul style="list-style-type: none"> <li>o Location</li> <li>o Size / height</li> <li>o Layout / configuration</li> <li>o Shadow Studies</li> <li>o Seating provision</li> </ul> </li> <li>Activity Generating Uses:                             <ul style="list-style-type: none"> <li>o Indicate location on plan and provide details on specific nature of use</li> </ul> </li> </ul>

# Section 3: Specific Requirements by Regulatory Agencies

## Urban Redevelopment Authority (URA)

INTRODUCTION TO CX

GENERAL REQUIREMENTS

• **REGULATORY AGENCIES** •

• KEY GATEWAYS •

• OTHER BUILDING WORKS •

BIM DATA REPRESENTATION



# Urban Redevelopment Authority (URA)

Legend:



Architecture



C&S



M&E

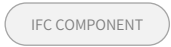

### G1 Design Gateway *(continued from previous page)*

Key Words	Requirement Category
<p>Rapid Transit System (RTS) Station</p> <p>ACCESSIBLE ROUTE    SITE BOUNDARY</p> <p>SPACE    SITE</p>	<p><b>Urban Design Requirements</b></p> <ul style="list-style-type: none"> <li>• Lines of Road Reserve / Site boundary of adjacent land parcels</li> <li>• Location of station box and its associated tunnels &amp; structures</li> <li>• Land take required (footprint to be optimised to minimise the land-take)</li> <li>• Details of Loading Provision (e.g. Loading grid plan)</li> <li>• Design of pop-up &amp; ancillary structures (within approved railway, setback, mitigation of platform levels, interfacing with neighbouring developments, CW provision)</li> <li>• Annotation for at-grade servicing areas (e.g. bin centre, loading / unloading bays, required to serve the retail uses within the station)</li> <li>• Integration approach with existing / future structures (e.g. location / orientation / size of vents)</li> <li>• Connectivity with other transport infra structure facilities and key pedestrian routes</li> <li>• Taxi stand / Vehicular drop-off</li> <li>• KOP details (e.g. exact alignment, size)</li> <li>• Retail quantum (capped at 2000 sqm), where relevant</li> </ul> <p> <b>Supporting Documents:</b></p> <ol style="list-style-type: none"> <li>a) Submission of RTS Checklist</li> <li>b) Method of construction (cut and cover , tunnel boring)</li> <li>c) Copy of the relevant approvals for the proposed retail quantum</li> </ol> <p><i>Note: Coordinated by the Architect, with inputs from respective engineers</i></p>
Roofscape	<ul style="list-style-type: none"> <li>• Location and extent of M&amp;E equipment</li> <li>• Location and extent of Outdoor Refreshment Area (ORA)</li> </ul>
<p>Service and Vehicular Access to Site</p> <p>ROAD    SPACE</p>	<p><b>Vehicular Access</b></p> <ul style="list-style-type: none"> <li>• Location of vehicular, pedestrian and cyclist access points, and layout of internal driveways</li> <li>• Integration with Building Envelope</li> </ul> <p><b>Service Areas</b></p> <ul style="list-style-type: none"> <li>• Location and integration with building envelope</li> <li>• Visual screening, where required</li> </ul>
<p>Site Layout only</p> <p>SPACE    ROAD</p> <p>SITE BOUNDARY    SITE</p>	<p><b>Building Setback from Boundary</b></p> <ul style="list-style-type: none"> <li>• Road Buffer</li> <li>• Common Boundary Setback / Party wall</li> <li>• Building Setback for Multi-Storey Car Parks (MSCP)</li> <li>• Boundary Setback for Ancillary Structures</li> <li>• Setback requirement for Urban Design areas</li> </ul> <p><b>Site Layout</b></p> <ul style="list-style-type: none"> <li>• Location of Buildings</li> <li>• Location and scale / size of Communal Facilities (e.g. bin centre, pavilions, BBQ areas)</li> </ul> <p><b>Site Coverage</b></p> <ul style="list-style-type: none"> <li>• Site coverage computation</li> </ul>

# Section 3: Specific Requirements by Regulatory Agencies

## Urban Redevelopment Authority (URA)

INTRODUCTION TO CX

GENERAL REQUIREMENTS

REGULATORY AGENCIES

KEY GATEWAYS

OTHER BUILDING WORKS

BIM DATA REPRESENTATION



# Urban Redevelopment Authority (URA)

Legend: ■ Architecture ■ C&S ■ M&E IFC COMPONENT

G1 Design Gateway <i>(continued from previous page)</i>	
Key Words	Requirement Category
<p>Site Layout, Landscape Deck</p> <div style="display: flex; justify-content: space-around; margin-bottom: 5px;"> <div style="border: 1px solid #ccc; border-radius: 10px; padding: 2px 5px; font-size: 8px;">PLANTING AREA</div> <div style="border: 1px solid #ccc; border-radius: 10px; padding: 2px 5px; font-size: 8px;">PLANTER BOX</div> </div> <div style="border: 1px solid #ccc; border-radius: 10px; padding: 2px 5px; font-size: 8px; margin-left: 20px;">SPACE</div>	<p><b><u>Landscape Deck</u></b></p> <ul style="list-style-type: none"> <li>Height of Deck in Relation to Existing Ground Levels</li> <li>Location and General Layout of Deck</li> </ul>
<p>Use &amp; Intensity</p> <div style="display: flex; justify-content: space-around; margin-bottom: 5px;"> <div style="border: 1px solid #ccc; border-radius: 10px; padding: 2px 5px; font-size: 8px;">SPACE</div> <div style="border: 1px solid #ccc; border-radius: 10px; padding: 2px 5px; font-size: 8px;">SITE BOUNDARY</div> </div> <div style="border: 1px solid #ccc; border-radius: 10px; padding: 2px 5px; font-size: 8px; margin-left: 20px;">SITE</div>	<ul style="list-style-type: none"> <li>Land Use / Building Uses - Provide breakdown by use quantum</li> <li>Gross Plot Ratio / Gross Floor Area computation</li> </ul> <p><b><u>Bonus GFA Incentive Schemes:</u></b></p> <ul style="list-style-type: none"> <li>Balcony / Recreational / Built Environment Transformation / Others – GFA quantum and %</li> <li>Documentation to support proposed scheme (if required)</li> </ul> <p><b><u>Site Boundary</u></b></p> <ul style="list-style-type: none"> <li>Site Area</li> <li>Land to be Vested for Public Schemes (Drain, Road, Open Space, Park, Cycling Paths)</li> <li>Land to be Amalgamated / Alienated</li> </ul> <p><b><u>Dwelling Units</u></b></p> <ul style="list-style-type: none"> <li>Maximum Number</li> <li>Pre-Application Feasibility Study (together with LTA)</li> </ul>
<p>Vehicular Parking</p> <div style="display: flex; justify-content: space-around; margin-bottom: 5px;"> <div style="border: 1px solid #ccc; border-radius: 10px; padding: 2px 5px; font-size: 8px;">PARKING LOT</div> <div style="border: 1px solid #ccc; border-radius: 10px; padding: 2px 5px; font-size: 8px;">SPACE</div> </div>	<p><b><u>Parking</u></b></p> <ul style="list-style-type: none"> <li>Show location within site</li> <li>Declare total number and breakdown of types</li> </ul>
<p>Others</p>	<div style="margin-bottom: 10px;"> <p><b><u>Urban Design Requirements</u></b></p> <ul style="list-style-type: none"> <li>Submission of DA Checklist</li> </ul> </div> <div style="margin-bottom: 10px;"> <p><b><u>Supplementary Documents</u></b></p> <ul style="list-style-type: none"> <li>Topo Survey Plan</li> <li>Previous approved plans (where requested by URA)</li> </ul> </div> <div style="margin-bottom: 10px;"> <p><b><u>Public Communications Plan (if applicable)</u></b></p> <p>Non-Government Land Sales (GLS) Sites</p> <ul style="list-style-type: none"> <li>If Public Communications Plan is required, URA will inform at Design Gateway submission, for project team's follow up distribution of flyers to the local community and submission of relevant forms</li> </ul> <p>GLS sites</p> <ul style="list-style-type: none"> <li>Public Communications Plan requirements, if any, will be clearly set out in the tender conditions. Flyers should have been distributed to the local community, and relevant forms already submitted.</li> </ul> </div> <div style="margin-bottom: 10px;"> <p><b><u>Development Statement of Intent</u></b></p> <ul style="list-style-type: none"> <li>Description of proposal (for relevant development types)</li> </ul> </div> <div> <p><b><u>RTS Checklist</u></b></p> <ul style="list-style-type: none"> <li>Submission of checklist for evaluation</li> </ul> </div>





# Urban Redevelopment Authority (URA)

Legend:



Architecture



C&S











M&E

IFC COMPONENT

## G1 Design Gateway *(continued from previous page)*

Key Words	Requirement Category
Others <i>(continued from previous page)</i>	 <b>Environmental Impact Assessment (where required)</b> <ul style="list-style-type: none"> <li>If development projects are near to sensitive areas (such as Nature Reserves, Nature Areas, marine and coastal areas, other areas of significant biodiversity) or might have potential trans-boundary impacts, relevant technical agencies (such as the National Parks Board, National Environment Agency, Maritime and Port Authority of Singapore, and Singapore Food Agency) will need to be consulted more extensively to determine if a more thorough environmental study is required.</li> <li>For affected proposals, URA will provide project teams with further instructions on how to proceed with such consultations.</li> </ul>

## G2 Construction Gateway - All Design Gateway requirements will apply, in addition to the following :-

Key Words	Requirement Category
Access to Site  	<b>Site Layout</b> <ul style="list-style-type: none"> <li>Detailed location of Pedestrian, Cycling, Vehicular and Service Access</li> </ul>
Access within Building only 	<ul style="list-style-type: none"> <li>Corridor width</li> </ul>
Attic 	<ul style="list-style-type: none"> <li>Design of attic</li> <li>Location of attic in relation to strata unit</li> </ul>
Balcony 	<b>Balconies, Private Enclosed Spaces, Private Roof Terraces and Indoor Recreation Spaces</b> <ul style="list-style-type: none"> <li>Balcony screening design illustrating openness and porosity for natural ventilation</li> </ul>
	 <b>Bonus Balcony GFA</b> <ul style="list-style-type: none"> <li>Letter of Declaration from Developer on Balcony Screen Design and Provision</li> </ul>
Building / Unit Layout 	<b>Unit / Floor Layout (All)</b> <ul style="list-style-type: none"> <li>Floor layout and unit size</li> <li>Strata areas and boundaries / voids</li> </ul>
	<b>Dwelling Units (Residential)</b> <ul style="list-style-type: none"> <li>Breakdown of units by type / size</li> <li>Unit layouts with breakdown of respective internal areas including balconies and air-con ledges</li> </ul>
Building Facade	 <b>Design Treatment for Building Facade</b> <ul style="list-style-type: none"> <li>Illustrate design using perspectives</li> <li>Screening details of M&amp;E equipment / multi-storey carpark, where required</li> </ul>
Common Services Tunnel	<ul style="list-style-type: none"> <li>Detailed Work sequence of CST vent shaft/entrance integration</li> <li>Link chamber services connection layout and structural details including supporting structures</li> <li>Ventilation shaft/entrance details including louvres/screening details and supporting structures</li> <li>Waterproofing details</li> </ul>

# Section 3: Specific Requirements by Regulatory Agencies

## Urban Redevelopment Authority (URA)

INTRODUCTION TO CX

GENERAL REQUIREMENTS

• **REGULATORY AGENCIES** •

• KEY GATEWAYS •

• OTHER BUILDING WORKS •

BIM DATA REPRESENTATION



# Urban Redevelopment Authority (URA)

Legend:



Architecture



C&S



M&E

IFC COMPONENT

G2 Construction Gateway - All Design Gateway requirements will apply, in addition to the following :-	
Key Words	Requirement Category
Connectivity   	<b><u>Pedestrian Network</u></b> Through Block Link (TBL), Underground Pedestrian Link(UPL), Elevated Pedestrian Link (EPL), Covered Walkways (CW), Open Walkways (OW), Covered Linkways (CL), High Covered Linkways (HCL) <ul style="list-style-type: none"> <li>• Loading provision to receive future walkways / linkways (if any)</li> <li>• Notional scheme for future link to justify the loading (recipient)</li> </ul>
Connectivity <i>(continued from previous page)</i>	Additional requirements for the following: <ul style="list-style-type: none"> <li>• (CW) Soffit height, overall width and clear width</li> <li>• (OW/CW) Paving material (where required in UD guidelines)</li> <li>• (OW/CW) Level of bulk water meter chamber / inspection chamber</li> <li>• (TBL) Location and Size of Signage</li> <li>• (HCL) Flashing to prevent wind driven rain</li> </ul>
	<b><u>Walking and Cycling Plan</u></b> <ul style="list-style-type: none"> <li>• Connectivity between buildings – show layout on plans, indicate width and levels</li> <li>• Segregation between vehicular and pedestrian / cyclist traffic</li> <li>• Provision of biking lots and end-of-trip facilities – show location and GFA exemption</li> </ul>
Conservation	<a href="#">Refer to URA Conservation Requirements here</a>
Earthworks / Topography 	<b><u>Earthworks, Retaining Walls, and Boundary Walls</u></b> <ul style="list-style-type: none"> <li>• Proposed site and platform levels</li> <li>• Earthworks</li> <li>• Boundary wall</li> <li>• Retaining wall</li> </ul>
External Works 	<ul style="list-style-type: none"> <li>• Design treatment for public street lighting, bollards, tactile tiles (UD requirement for CBD / Marina Bay)</li> <li>• Promenade Guidelines (UD requirements for Singapore River)</li> <li>• Paving Guideline for Orchard, Downtown Core and the Civic District (OW) Paving material</li> </ul>
Greenery  	<ul style="list-style-type: none"> <li>• Landscape Replacement Area – Provide Green Plot Ratio and total % of landscape replacement, with breakdown of hardscape and softscape</li> <li>• Declare Location of Sky Terrace / Planter Boxes / Covered Communal Ground Garden / Communal Pavilions</li> </ul> <b><u>Supplementary Documents</u></b> <ul style="list-style-type: none"> <li> a) Landscape plan / species and perspectives</li> <li> b) Plant details of sky terrace / planter boxes / covered communal ground garden / communal pavilions</li> </ul>
Night Lighting	<b><u>Night Lighting Report</u></b> <ul style="list-style-type: none"> <li> • Detailed concept and renders</li> <li> • Specifications</li> <li> • Fixture installation</li> </ul>
ORA / ODA / Kiosks	<ul style="list-style-type: none"> <li>• Location and extent, detailed design</li> </ul>

# Section 3: Specific Requirements by Regulatory Agencies

## Urban Redevelopment Authority (URA)

INTRODUCTION TO CX

GENERAL REQUIREMENTS

REGULATORY AGENCIES

KEY GATEWAYS

OTHER BUILDING WORKS

BIM DATA REPRESENTATION



# Urban Redevelopment Authority (URA)

Legend:



Architecture



C&S



M&E

IFC COMPONENT

G2 Construction Gateway - All Design Gateway requirements will apply, in addition to the following :-	
Key Words	Requirement Category
Public Space 	<b>Privately-Owned Public Spaces (POPS):</b> <ul style="list-style-type: none"> <li>Area verging of POPS</li> <li>Seating (design, no., location)</li> <li>Amenities (type, location)</li> <li>Signage (design, location)</li> <li>Outdoor Refreshment Areas (ORA) (if provided, location / extent)</li> </ul>
Roofscape	<ul style="list-style-type: none"> <li>Screening details of M&amp;E equipment, where required</li> <li>Use of RC Flat Roofs – Indicate whether roof is accessible, and if so, for what purpose</li> <li>Structures (If any)</li> </ul>
Rapid Transit System (RTS) Station 	<b>Urban Design Requirements</b> <ul style="list-style-type: none"> <li>Design and location of at-grade bicycle parking</li> </ul> <b>Draft Development Interface Report</b> <ol style="list-style-type: none"> <li>For works interfacing with existing / future connection</li> <li>Architectural information for future developer (e.g. fire safety requirements; Knock Out Panels (KOP))</li> <li>Structural information for future developer (e.g. Loading requirements)</li> <li>Mechanical and Electrical (M&amp;E) information for future developer (e.g. ventilation shaft location and throw)</li> <li>Details of Loading Provision</li> </ol> <p>Note: Coordinated by the Architect, with inputs from respective engineers</p>
Signage	<b>Privately-Owned Public Spaces (POPS), Through Block Link (TBL) Signage</b> <ul style="list-style-type: none"> <li>Location and size of signages</li> </ul>
Site Layout only 	<b>Building Setback from Boundary</b> <ul style="list-style-type: none"> <li>Setback for Building Appendages – Location and width</li> <li>Treatment for non-compliant Multi-Storey Car Parks and Ancillary Structures</li> </ul>
Site Layout, Basement 	<b>Basements</b> <ul style="list-style-type: none"> <li>Basement protrusion (if any) and location within site</li> <li>Screening of basement opening</li> </ul>
Site Layout, Landscape Deck 	<b>Landscape Deck</b> <ul style="list-style-type: none"> <li>Exposure of Basement Wall &amp; Proposed Treatment (Berm / Vertical Greenery)</li> <li>Site Coverage on Landscape Deck – declare %</li> <li>Provision of Greenery on Deck – Location and %</li> <li>Boundary Wall Porosity – declare % and show design</li> </ul>
Site Layout, Security Screening	<b>Security Screening (where required)</b> <ul style="list-style-type: none"> <li>If the site falls within a special control area, it will need to comply with security screening requirements, if any</li> </ul>
Strata Area	<ul style="list-style-type: none"> <li>To demarcate the strata areas on the floor plans</li> </ul>
Structures in Building Setback, Green Buffer	<ul style="list-style-type: none"> <li>Location (e.g. integrated with building envelope)</li> <li>Finish material of manhole to match paving if located within covered / open walkway)</li> </ul>





# Urban Redevelopment Authority (URA)

Legend:  Architecture  C&S  M&E IFC COMPONENT

G2 Construction Gateway - All Design Gateway requirements will apply, in addition to the following :-	
Key Words	Requirement Category
Use & Intensity	<ul style="list-style-type: none"> <li>Gross Plot Ratio / Gross Floor Area</li> <li>Land Use / Building Uses – detailed breakdown by use and GFA quantum</li> </ul> <p>{Note: For time-being, submission of the native BIM models is required to facilitate GFA verification. The native models can be provided at the resubmission to CG i.e. where QPs expect to obtain Written Permission as part of CG Clearance}</p> <p><b>Bonus GFA Incentive Schemes:</b></p> <ul style="list-style-type: none"> <li>Balcony / Recreational / Transformation / Others – GFA quantum and %</li> </ul>
Vehicular Parking <div style="display: flex; justify-content: space-around; margin-top: 5px;"> <div style="border: 1px solid gray; border-radius: 15px; padding: 2px 5px; font-size: 8px;">PARKING LOT</div> <div style="border: 1px solid gray; border-radius: 15px; padding: 2px 5px; font-size: 8px;">SPACE</div> </div>	<ul style="list-style-type: none"> <li>Total number of parking lots (including motorcycle parking)</li> <li>Residual area within car park floors to be demarcated</li> <li>Screening details for vehicular parking and service areas</li> </ul>
Others	<div style="margin-bottom: 5px;"> <b>Environmental Impact Assessment (where required)</b> <ul style="list-style-type: none"> <li>Submission of any other documents required</li> </ul> </div> <div style="margin-bottom: 5px;"> <b>Supplementary Documents</b> <ul style="list-style-type: none"> <li>Previous approved plans (where requested by URA)</li> </ul> </div> <div style="margin-bottom: 5px;"> <b>Public Communications Plans (if applicable)</b> <ul style="list-style-type: none"> <li>Distribution of flyers prior to CG submission and submission of relevant forms, where required</li> </ul> </div> <div style="margin-bottom: 5px;"> <b>Form on Unit Information</b> <ul style="list-style-type: none"> <li>To provide a tabulation on unit-level information for each submission/resubmission at CG and TOP/CSC stage. More information will be available on the URA website under DC Supplementary Forms.</li> </ul> </div> <div style="margin-bottom: 5px;"> <b>Design Advisory Panel (DAP) Report</b> <ul style="list-style-type: none"> <li>Urban design and architectural information for DAP to assess (e.g. renders; diagrams showing sheltered pedestrian route)</li> </ul> </div> <div> <b>Pre-CG Submission: Stage 2 Design Advisory Panel – for selected projects</b> <ul style="list-style-type: none"> <li>The DAP materials submitted are to consist of :               <ul style="list-style-type: none"> <li>Technical drawings (including a full set of plans, elevations and sections)</li> <li>Digital and hardcopy DAP booklets (including 2 hardcopies in A3), which should not exceed 50 pages, including appendices, attached drawings and plans, with a minimum font size of 12.</li> <li>Presentation slides. The number of presentation slides should be comfortable for a 20-minute presentation without lengthy text, highlighting the key points with further elaboration provided in the DAP booklet.</li> <li>Digital models</li> <li>Where necessary, a physical model of the proposed development will be required, at scale of 1:400 or smaller (to be advised by the officer in charge), showing context of site] will have to be submitted.</li> <li>Additional reports, such as Conservation Reports, are to be included as Appendices to the A3 booklets</li> </ul> </li> </ul> </div>



# Urban Redevelopment Authority (URA)

Legend:



Architecture



C&S



M&E

IFC COMPONENT

## G2 Construction Gateway - All Design Gateway requirements will apply, in addition to the following :-

Key Words	Requirement Category
Others <i>(Continued from previous page)</i>	<p><b>Pre-CG Submission: Stage 2 Design Advisory Panel – for selected projects</b></p> <ul style="list-style-type: none"> <li>The following aspects of the proposal will be assessed at this stage of the DAP:                             <ul style="list-style-type: none"> <li>Detailed building layout</li> <li>Detailed architectural treatment including appropriate use of building materials and finishes</li> <li>Night lighting design concept, including method statement and detailed drawings on how the night lighting intention would be achieved</li> <li>Detailed landscaping design including planting palette</li> <li>Detailed Design of Public Spaces</li> <li>Scaled elevations and sections of the relevant details (preferably 1:50 in hardcopy), digital architectural model of part(s) of the building (if necessary), as well as material samples of the façade and roof materials are required to be submitted to show the architectural design of the development</li> </ul> </li> </ul>

## - Independent Submission

Key Words	Requirement Category
Conservation	<a href="#">Refer to URA Conservation Requirements here</a>
Land / Strata Subdivision and Amalgamation	<p><b>Land / Strata Subdivision and Amalgamation</b></p> <ul style="list-style-type: none"> <li>Proposed Subdivision and/or Amalgamation plan(s) / model by Registered Surveyor</li> </ul>
Demolition Works (For noting)	<p>If developers intend to proceed with demolition works ahead of obtaining DSP or DG Clearance, a demolition application for the demolition works will be required, accompanied by the payment of requisite fees to both URA and BCA.</p> <p>URA will not require a separate demolition application if the works to be demolished are :</p> <ul style="list-style-type: none"> <li>Shown within the proposal granted planning permission, or</li> <li>A lodgment application has been made and URA's authorisation letter has been granted for a new erection or a reconstruction proposal that necessitates the demolition of any existing building structures.</li> </ul>

## G3 Completion Gateway

Item for TOP / CSC	Requirement Category
Development Interface Report (DIR) (Final)	<ul style="list-style-type: none"> <li>Information for future developer (e.g. loading requirements, knock out panels alignment / width)</li> <li>As-built plan</li> </ul>
TOP / CSC	<ul style="list-style-type: none"> <li>Declaration that completed works have been supervised and built in accordance to approved plans (via EDASForm)</li> <li>Photographs of completed works or rectifications (where requested)</li> <li>Phasing Plan (for Partial TOP)</li> <li>Inspections (where necessary)</li> </ul>
Record Plan (for non-conserved buildings and monuments)	<ul style="list-style-type: none"> <li>As-built plan incorporating approved amendments and as-built works that QPs declared to not have material impact to planning controls</li> </ul>



----- **End of Requirements for URA** -----

# SECTION 3

## Specific Requirements by: *Key Gateways*



## 3 Specific Requirements by

	<b>Page</b>
	
<b>Regulatory Agencies</b>	
• BCA	29
• LTA	40
• NEA	46
• NParks	56
• PUB	60
• SCDF	63
• URA	72
	
<b>Key Gateways</b>	
Overview	85
Glossary of Common Key Words	86
- Pre-Submission, Planning and Other Consultations	89
• <b>G1</b> Design Gateway	96
• <b>G1.5</b> Piling Gateway (Optional)	113
• <b>G2</b> Construction Gateway	116
- Independent Submissions	143
• <b>G3</b> Completion Gateway (TOP/CSC)	151
	
<b>Other Building Works</b>	
• Overview of External Works	159
○ LTA	161
○ NParks	171
○ PUB	174
• Direct Submission Process (DSP)	178
• Conservation	179
• Part ST Submission	181
• Infrastructure Works	186

# Section 3: Specific Requirements by Key Gateways

## Overview

INTRODUCTION TO CX

GENERAL REQUIREMENTS

REGULATORY AGENCIES

**KEY GATEWAYS**

OTHER BUILDING WORKS

BIM DATA REPRESENTATION

## About the Gateways



G	Gateways	Objectives	Key Approvals
-	Pre-Submission, Planning and Other Consultations	To seek one or more agencies' guidance and/or waivers on a project's submission requirements before making a formal submission	-
G1	<b>Design Gateway (DG)</b> For Design Parameters	To resolve multi-agency key parameters which have impact on design parameters and client's brief, before proceeding to detailed design.	<ul style="list-style-type: none"> <li>URA PP</li> <li>LTA, NEA and PUB DC Clearances</li> <li>NParks DC Approval</li> </ul>
G1.5	<b>Piling Gateway (PG)</b> *optional	To resolve requirements pertaining to piling and foundation works (e.g. pile caps, raft foundation, earth retaining and stabilising structures), excluding superstructural works.	<ul style="list-style-type: none"> <li>BCA ST Approvals for Permanent Piling Works</li> <li>LTA RPZ AIP for Pile Design and Pile Layout Plan</li> <li>NParks Acceptance of Environmental Management and Monitoring Plan (EMMP)/wildlife management plan, if applicable</li> </ul>
G2	<b>Construction Gateway (CG)</b>	To resolve multi-agency requirements concerning design details that need to be coordinated before commencement of main structural works and launch of Sales.	<ul style="list-style-type: none"> <li>URA WP</li> <li>BCA BP and ST Approvals</li> <li>LTA Street Plan Clearance, BP (Parking), BP (Rails)</li> <li>NEA and PUB BP Clearance Certificate</li> <li>SCDF BP Approval</li> <li>NParks CG Approval</li> <li>NParks Acceptance of Environmental Management and Monitoring Plan (EMMP)/wildlife management plan, if applicable</li> </ul>
-	Independent Submissions (IDP) *if applicable	To clear agency-specific requirements with no cross-agency dependencies (i.e. typically affecting only one relevant agency). E.g. structural submission of ancillary structures such as barriers/claddings to BCA	<ul style="list-style-type: none"> <li>PUB Earth Control Measures Approval</li> <li>NParks Acceptance of Environmental Management and Monitoring Plan (EMMP)/wildlife management plan, if applicable</li> </ul>
G3	<b>Completion Gateway (TOP)</b> Application for TOP/CSC	To document "As-Built" plans and obtain Occupancy Permit/ Statutory Completion	-

For simpler projects, please refer to the Direct Submission Process (DSP) [here](#).

Example of a project making regulatory submissions across CORENET X Gateways

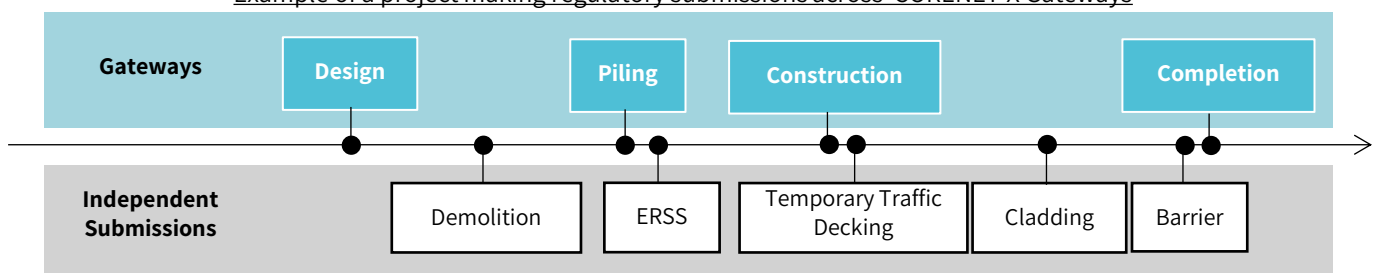

## Common Gateway Key Words

Key Words in alphabetical order		-	G1	G1.5	G2	-
		Pre-Submission & Planning Consultation	Design Gateway	Piling Gateway	Construction Gateway	Independent Submissions
<b>A</b>	ABC Waters		PUB		PUB	
	Access to Site		URA		BCA, URA	
	Access within Building only				BCA, URA	
	Attic				URA	
<b>B</b>	Balcony				URA	
	Barrier				BCA	BCA
	Buildability				BCA	BCA
	Building / Unit Layout				URA	
	Building Envelope				BCA	
	Building Facade				URA	
	Building Massing		URA		URA	
<b>C</b>	Common Service Tunnel (CST)		URA		URA	
	Connectivity		URA		URA	BCA
	*Conservation	URA	URA		URA	URA
	Constructability					BCA
<b>D</b>	Demolition Works (For noting)					URA
	Detention System (External)		PUB			
	Dwelling Unit				BCA	
<b>E</b>	Earthworks / Topography		PUB, URA		PUB, URA	
	Emergency Voice Communication System				SCDF	
	Environmental Sustainability				BCA	BCA
	Environmental Health (COPEH)		NEA		NEA	
	Exit				SCDF	
	Exit Sign and Emergency Lighting				SCDF	
	External Works		URA		URA	
<b>F</b>	Façade					BCA
	Fire Alarm System				SCDF	
	Firefighting System				SCDF	
	Fire Engine Accessway / Access Road		SCDF			
	Fire Lift				SCDF	
<b>G</b>	Greenery	NParks	NParks, URA		NParks, URA	NParks
<b>H</b>	Headroom and Ceiling height				BCA	
	Household / Storey Shelter (HS/SS)	BCA			BCA	

\* Conservation Requirements are in a separate chapter [here](#).

\* External Works Requirements are in a separate chapter [here](#).

## Section 3: Specific Requirements by Key Gateways Overview

### Common Gateway Key Words

Key Words in alphabetical order <i>continued from previous page</i>		-	G1	G1.5	G2	-
		Pre-Submission & Planning Consultation	Design Gateway	Piling Gateway	Construction Gateway	Independent Submissions
<b>I</b>	Impact Studies only	LTA, NEA, NParks, URA	NEA, NParks	NParks	LTA, NParks	NEA
	Impact Studies, Site Layout, Rail Protection, Road Structure Protection		LTA	LTA	LTA	LTA
	<a href="#">*Infra &amp; Utilities (External)</a>	External Works Requirements are in a separate chapter <a href="#">here</a> .				
	Infra & Utilities (Internal)		PUB, URA		PUB	
<b>L</b>	Land/Strata Subdivision & Amalgamation					URA
	Lifts and Escalators				BCA	
	Lightning Protection			BCA	BCA	BCA
	Loading / Development Loading		URA			
<b>M</b>	Materials				BCA	
	Mechanical Ventilation & Smoke Control System				SCDF	SCDF
<b>N</b>	Night Lighting		URA		URA	
<b>O</b>	ORA / ODA / Kiosks		URA		URA	
<b>P</b>	Performance Based project				SCDF	
	Platform & Crest Level only	PUB	PUB			
	Pollution Control (COPPC)				NEA	
	Public Communications Plan (PCP)	URA				
	Public Drains (Internal)		PUB			
	<a href="#">*Public Drains (External)</a>	PUB				PUB
	<a href="#">*Public Sewerage System (External)</a>	PUB		PUB		PUB
	Public Space		URA		URA	
	Public Transit Shelter (PS/TS)	BCA			BCA	BCA
<b>R</b>	Rapid Transit System (RTS) Station		URA		URA	
	Roofscape		URA		URA	
<b>S</b>	Sanitary (Internal)	PUB	PUB			
	Service & Vehicular Access to Site		URA			
	Signage				URA	BCA
	Site Layout only	NEA, URA	NEA, NParks, URA		URA	
	Site Layout, Basement				URA	
	Site Layout, Drainage Reserve		PUB			
	Site Layout, Landscape Deck		URA		URA	

\* Conservation Requirements are in a separate chapter [here](#).

\* External Works Requirements are in a separate chapter [here](#).

## Common Gateway Key Words

Key Words in alphabetical order <i>continued from previous page</i>		-	G1	G1.5	G2	-
		Pre-Submission & Planning Consultation	Design Gateway	Piling Gateway	Construction Gateway	Independent Submissions
<b>S</b>	Site Layout, Security Screening				URA	
	Site Layout, Street Works		LTA		LTA	
	Site Layout, Vehicular Parking	LTA			LTA	
	Site Planning & External Firefighting Provisions				SCDF	
	Smoke Control System Declaration				SCDF	
	Staircase				BCA	
	Strata Area				URA	
	Statistical Gross Floor Area (SGFA)				SCDF	
	Structural Design			BCA	BCA	BCA
	Structural Fire Precautions				SCDF	
	Structures in Building Setback, Green Buffer				URA	
<b>U</b>	Use & Intensity		URA		URA	
<b>V</b>	Vehicular Parking		LTA, URA		BCA, URA	
	Ventilation				BCA	
<b>W</b>	Washroom				BCA	
	Water Supply					PUB
-	<i>Others</i>	BCA, URA	BCA, URA		URA, SCDF	

\* Conservation Requirements are in a separate chapter [here](#).

\* External Works Requirements are in a separate chapter [here](#).





# Pre-Submission, Planning and Other Consultations

Legend:  Architecture  C&S  M&E IFC COMPONENT

Household / Storey Shelter	
Agency	Requirement Category
BCA	<ul style="list-style-type: none"> <li>Pre-consultation on HS/SS shelter on architectural, structural or commissioning issues</li> <li>Can occur at any stage prior to TOP, for landed and non-landed residential projects</li> </ul>

Greenery	
Agency	Requirement Category
NParks	<div style="display: flex; align-items: flex-start;"> <div style="margin-right: 10px;"> </div> <div> <p><b><u>Greenery Provision and Conservation of Trees / Plants</u></b></p> <ul style="list-style-type: none"> <li>Pre-Submission consultation of requirements for greenery provision and tree conservation for developments</li> </ul> </div> </div>

Impact Studies only	
Agency	Requirement Category
LTA	<div style="display: flex; align-items: flex-start;"> <div style="margin-right: 10px;"> </div> <div> <p><b><u>Transport Impact Assessment (TIA)</u></b></p> <ul style="list-style-type: none"> <li>Generally, a TIA submission is required if the type and size of the proposed development meets one or more of the criteria stipulated in LTA's guidelines.</li> <li>The traffic consultant shall arrange scoping meeting with LTA to discuss the scope of study, TIA classifications and confirm if Walking and Cycling Plan (WCP) is required.</li> <li>The TIA report is to be set out logically with clear analyses, conclusions and recommendations. All assumptions and sources of information are to be clearly documented. Executive Summary shall be included to provide concise and clear information on the study purpose, major findings, conclusions and recommendations. Improvements recommended in the TIA are to be illustrated using appropriate plan(s) with sufficient detail to substantiate their feasibility. All the analysis files and data related to the study are to be submitted as appendices to the Report for LTA's records.</li> <li>All recommended improvement works to be carried out by the developer shall be incorporated in the development plan submissions at Design Gateway (G1) and Construction Gateway (G2) to LTA for clearance.</li> </ul> </div> </div>
	<div style="display: flex; align-items: flex-start;"> <div style="margin-right: 10px;"> </div> <div> <p><b><u>Pre-Application Feasibility Study &amp; Recommendations</u></b></p> <ul style="list-style-type: none"> <li>LTA should be consulted to confirm whether a PAFS is needed for the proposed residential site if they are undergoing redevelopment arising from a collective or en-bloc sales.</li> <li>The traffic consultant shall arrange scoping meeting with LTA to discuss the scope of study</li> <li>PAFS should assess the traffic impact on the area and propose car-lite measures/initiatives, traffic demand management measures and/or feasible transport improvement plans to support the redevelopment proposal.</li> <li>All recommended improvement works to be carried out by the developer shall be incorporated in the development plan submissions at Design Gateway (G1) and Construction Gateway (G2) to LTA for clearance.</li> </ul> </div> </div>
	<div style="display: flex; align-items: flex-start;"> <div style="margin-right: 10px;"> </div> <div> <p><b><u>Walking and Cycling Plan (WCP)</u></b></p> <ul style="list-style-type: none"> <li>The rigorous process of the WCP shall be demonstrated and presented in a written report that explains the rationale for the following 5 sets of plans:                             <ol style="list-style-type: none"> <li>1. Location and Connectivity Plan</li> <li>2. Circulation Plan</li> <li>3. Conflict Mitigating Plan</li> <li>4. Bicycle Parking and End of Trip Facility Plan</li> <li>5. Wayfinding Plan</li> </ol> </li> </ul> </div> </div>
NEA	<div style="display: flex; align-items: flex-start;"> <div style="margin-right: 10px;"> </div> <div> <p><b><u>Environmental Information (EI)</u></b></p> <ul style="list-style-type: none"> <li>Applicants are required to apply EI from NEA directly at Pre-Submission</li> </ul> </div> </div>



# Pre-Submission, Planning and Other Consultations

Legend:



Architecture









C&S



M&E

IFC COMPONENT

## Impact Studies only (continued from previous page)

Agency	Requirement Category
NEA <i>(continued from previous page)</i>	 <b>Environmental Impact Study (EIS-Pre)</b> <ul style="list-style-type: none"> <li>Applicants are required to submit EIS (Pre) to NEA directly at Pre-Submission</li> <li>If Pre-Submission is not possible, the EIS (Pre) process should be concluded by Design Gateway (G1)</li> </ul>
	 <b>Energy Efficiency Opportunities Assessment (EEOA) for New Ventures</b> <ul style="list-style-type: none"> <li>Applicants are required to submit EEOA reports to NEA directly via email to <a href="mailto:DCLD_consultation@nea.gov.sg">DCLD_consultation@nea.gov.sg</a>.</li> </ul> Note: NEA is currently reviewing the submission requirements for EEOA
	 <b>Environmental Site Assessment (ESA)</b> <ul style="list-style-type: none"> <li>Applicants should submit ESA to NEA directly and should be concluded at Pre-Submission</li> </ul>
	 <b>Noise Impact Assessment (NIA-Pre) for Traffic</b> <ul style="list-style-type: none"> <li>Applicants are required to submit NIA (Pre) report to NEA directly via email to <a href="mailto:DCLD_consultation@nea.gov.sg">DCLD_consultation@nea.gov.sg</a> at Pre-Submission</li> <li>If Pre-Submission is not possible, the NIA (Pre) process should be concluded by Design Gateway (G1)</li> <li>However, applicant may submit NIA (Pre) report to NEA directly at Construction Gateway (G2) if there is no Design Gateway (G1) submission for the development</li> </ul>
	 <b>Pollution Control Study (PCS)</b> <ul style="list-style-type: none"> <li>Applicants are required to submit PCS report to NEA directly via email to <a href="mailto:DCLD_consultation@nea.gov.sg">DCLD_consultation@nea.gov.sg</a> at Pre-Submission</li> <li>If Pre-Submission is not possible, the PCS process should be concluded by Design Gateway (G1)</li> </ul> Note: NEA is currently reviewing the submission requirements for PCS
	 <b>Quantitative Risk Assessment (QRA)</b> <ul style="list-style-type: none"> <li>If QRA is required, applicants are required to submit QRA report to MOM-MHD for dissemination to respective agencies (including NEA).</li> <li>The QRA report should be accepted by agencies before Design Gateway (G1)</li> </ul> Note: NEA is currently reviewing the submission requirements for QRA
NParks	 <b>Biodiversity Impact Assessment (under URA's EIA Framework)</b> <ul style="list-style-type: none"> <li>Applicable to sites not identified as Planning Stage (Pre-DG) to fall within the Environmental Impact Assessment Framework:                             <ul style="list-style-type: none"> <li><u>Environmental Consultation</u> <ul style="list-style-type: none"> <li>QP (Arch / PEs) or Consultant to submit the environmental consultation form (Form A) to URA and Technical Agencies (e.g. NEA, NParks, MPA, SFA) – via URA's EPACS.</li> <li>Details of project entities (Developer, Qualified Person and Main Contractor) as stated in Form A are provided</li> </ul> </li> <li><u>Environmental Impact Assessment</u> <ul style="list-style-type: none"> <li>QP (Arch / PEs) or Consultant can consult on environmental baseline study and scoping of EIA</li> <li>QP (Arch / PEs) or Consultant to ensure that EIA report (for projects that have cleared environmental assessment at planning stage) are submitted for acceptance</li> </ul> </li> </ul> </li> <li>If Pre-Submission is not possible, the environmental consultation process should be concluded by Piling Gateway (G1.5) or Construction Gateway (G2)</li> <li>There might be requirement for detailed EMMP / wildlife management prior to site clearance</li> </ul>



# Pre-Submission, Planning and Other Consultations

Legend:



Architecture



C&S



M&E

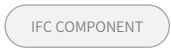

IFC COMPONENT

## Impact Studies only *(continued from previous page)*

Agency	Requirement Category
NParks  <i>(continued from previous page)</i>	<ul style="list-style-type: none"> <li>☑ <b>Assessment and Reduction of Biodiversity Impact (under URA's Environmental Impact Assessment [EIA] framework)</b> <ul style="list-style-type: none"> <li>• Should be surfaced ahead of the submission</li> <li>• If pre-submission is not possible, the environmental consultation process should be concluded by Design Gateway (G1) or Piling Gateway (G1.5)</li> <li>• There might be requirement for EMMP / wildlife management prior to site clearance</li> </ul> </li> </ul>
URA	<ul style="list-style-type: none"> <li>☑ <b>Environmental Impact Assessment (where required)</b> <ul style="list-style-type: none"> <li>• If development projects are near to sensitive areas (such as Nature Reserves, Nature Areas, marine and coastal areas, other areas of significant biodiversity) or might have potential trans-boundary impacts, relevant technical agencies (such as the National Parks Board, National Environment Agency, Maritime and Port Authority of Singapore, and Singapore Food Agency) will need to be consulted more extensively to determine if a more thorough environmental study is required.</li> <li>• For affected proposals, URA will provide project teams with further instructions on how to proceed with such consultations</li> </ul> </li> </ul>

## Platform Levels

Agency	Requirement Category
PUB	<b>Minimum Platform Level</b> <ul style="list-style-type: none"> <li>• SHD</li> </ul>

## Public Communications Plan (PCP)

Agency	Requirement Category
URA	<p>Please note that the PCP process will differ for submissions made through CORENET X</p> <p><b>Non-Government Land Sale (GLS) Sites</b></p> <ul style="list-style-type: none"> <li>• If a Public Communications Plan is required, it will be made known at Design Gateway submission, where URA will provide guidance on the follow up distribution of flyers to the local community and submission of relevant forms.</li> </ul> <p><b>GLS Sites</b></p> <ul style="list-style-type: none"> <li>• Public Communications Plan requirements, if any, will be clearly set out in the tender conditions. For projects that are submitted to CORENET X, the Developer/QPs can reach out to the relevant Sales Agent</li> </ul>

## Public Drains (External)

Agency	Requirement Category
PUB  CULVERT	<p><b>Roadside Drain Capacity</b></p> <ul style="list-style-type: none"> <li>• For projects where drains need to be rebuilt / entrance culvert. PUB to provide required size during pre-submission consultation</li> <li>• Size of new culvert (will be advised by PUB)</li> <li>• Public Drains - Drain Size and Location</li> </ul> <p><b>Pre-Consultation for Sewers</b></p> <ul style="list-style-type: none"> <li>• Sewerage Discharge Point</li> <li>• Used water discharge volume</li> </ul> <p><b>Pre-Consultation for Drainage (via email)</b></p> <ul style="list-style-type: none"> <li>• Drainage Discharge Point</li> <li>• Catchment Area</li> </ul>



## Pre-Submission, Planning and Other Consultations

Legend:  Architecture  C&S  M&E IFC COMPONENT

Public Transit Shelter (PS/TS)		
	Agency	Requirement Category
	BCA	<ul style="list-style-type: none"> <li>Pre-consultation on Public/Transit Shelter (PS/TS) on architectural, structural, M&amp;E or commissioning issues</li> <li>Can occur at any stage prior to TOP</li> </ul>

Public Sewerage System (External)		
	Agency	Requirement Category
	PUB	<p><b><u>Pre-Consultation for Sewers</u></b></p> <ul style="list-style-type: none"> <li>Sewerage Discharge Point</li> </ul>

Sanitary (Internal)		
	Agency	Requirement Category
	PUB	<p><b><u>Pre-consultation for Sanitary</u></b></p> <ul style="list-style-type: none"> <li>Used water discharge volume</li> </ul>

Site Layout only		
	Agency	Requirement Category
	NEA	<p><b><u>Environmental Health (COPEH)</u></b></p> <ul style="list-style-type: none"> <li>Refuse Truck Access Road (For Refuse Collection) – Swept Path Analysis</li> <li>Location and Size of the Bin Centre / Refuse Room / Bin Point, refuse chute and recycling chute, refuse chute chamber and recyclables storage &amp; its collection system</li> <li>Provide total daily refuse outputs (liters/day) for the development</li> <li>Pneumatic waste conveyance system (PWCS) schematic plan</li> <li>Location of cooling tower and its setback distance (at least 5m)</li> </ul> <p><b>When to apply:</b></p> <ul style="list-style-type: none"> <li>Applicants should provide the above information (either in 2D, 3D or supporting documents) and should be concluded by Design Gateway (G1)</li> <li>However, applicant may submit the above information at Pre-submission if the development does not require any Design Gateway (G1)</li> </ul> <p><b>Who to submit:</b></p> <ul style="list-style-type: none"> <li>QP appointed should submit the above information and keep other relevant QPs in the loop.</li> <li>The same QP should follow through the submissions for all gateways</li> </ul> <p><b><u>Pollution Control (COPPC)</u></b></p> <ul style="list-style-type: none"> <li>Confirm the proposed development is aligned with the prevailing URA MP land use zoning (e.g. residential to residential)</li> <li>Building location and its surrounding development/amenities (such as expressway/major road, MRT/MRT station, place of worship, hospital, petrol station, industry premises etc.)</li> <li>Orientation and location of nuisance sources (e.g. cooling towers, chiller plants, air handling units, air conditioning condensers, fresh air intake, exhaust outlets (ventilation shaft), etc.)</li> <li>50m nuisance buffer from place of worship, petrol station, Light industry premises to the nearest residential development.</li> </ul>



# Pre-Submission, Planning and Other Consultations

Legend: ■ Architecture ■ C&S ■ M&E IFC COMPONENT

Site Layout only (continued from previous page)					
Agency	Requirement Category				
NEA	<p><b>Pollution Control (COPPC) (continued from previous page)</b></p> <ul style="list-style-type: none"> <li>100m nuisance buffer from General industry premises to nearest residential development.</li> <li>500m nuisance buffer from Special Industry premises to nearest residential development.</li> <li>Orientation of building: Minimum building setback (m)</li> </ul> <table border="1" style="margin-left: 20px;"> <tr> <td>Fronting track</td> <td>35</td> </tr> <tr> <td>End-wall facing track</td> <td>25</td> </tr> </table> <ul style="list-style-type: none"> <li>Setback distance within 70m from transport-related infrastructure (i.e. LTA road reserve line for expressway/major road) to the nearest residential development Lot boundary line.</li> <li>Location of the chimney and BHC and MCH requirements e.g. within 30m / 100m radius of existing chimney stack height</li> <li>Location changes for the storage inventory product / materials such as chemical, oil, fuel, etc</li> <li>Changes in the industrial processes or production activities location</li> <li>Changes of existing activity, expansion of existing activities or proposed new activity carried out on the proposed development or premises</li> </ul> <p><b>When to apply:</b></p> <ul style="list-style-type: none"> <li>Applicants should provide the above information (either in 2D, 3D or supporting documents) and should be concluded by Design Gateway (G1)</li> <li>However, applicant may submit the above information at Pre-submission if the development does not require any Design Gateway (G1)</li> </ul> <p><b>Who to submit:</b></p> <ul style="list-style-type: none"> <li>QP appointed should submit the above information and keep other relevant QPs in the loop.</li> <li>The same QP should follow through the submissions for all gateways.</li> </ul>	Fronting track	35	End-wall facing track	25
	Fronting track	35			
End-wall facing track	25				
URA	<p> <b>Outline Application / Rezoning</b></p> <p>Where there are deviations to Master Plan parameters (e.g. land use, GPR, height, etc), the project team should consider submitting an outline application with the following details:</p> <ul style="list-style-type: none"> <li>Planning proposal data (e.g. site area, GFA and use breakdown, numbers of units/rooms)</li> <li>Site layout plan and form/massing schemes, where necessary</li> </ul> <p> <b>Pre-Application Consultation Service</b></p> <ul style="list-style-type: none"> <li>Details of proposals to clarify or seek deviation from specific guidelines</li> </ul> <p>[Note: This is a chargeable service which will allow QPs to discuss proposals that may depart from the usual guidelines and address certain planning issues upfront. To access this service, please make an application through URA's website - <a href="https://www.ura.gov.sg/pacsWeb/">https://www.ura.gov.sg/pacsWeb/</a>]</p>				

Site Layout, Vehicular Parking	
Agency	Requirement Category
LTA	<p> <b>Pre-Consultation on Mechanised Parking System Proposals</b></p> <ul style="list-style-type: none"> <li>QPs and developers are required to submit their mechanised parking system and car lifts proposals to LTA for a pre-submission consultation before a development application is submitted to the Urban Redevelopment Authority (URA) for planning permission. This will allow architects, engineers and developers to incorporate the necessary requirements into the design of the development upfront to minimise abortive work and major revisions to development proposals later.</li> <li>Refer to LTA's COP for Vehicle Parking Provision in Development Proposals for the design of a proper mechanised parking system and car lifts.</li> </ul>



# Pre-Submission, Planning and Other Consultations

Legend:  Architecture  C&S  M&E IFC COMPONENT

## Site Layout, Vehicular Parking *(continued from previous page)*

	Agency	Requirement Category
	LTA <i>(continued from the previous page)</i>	<div style="border: 1px solid gray; padding: 5px;"> <p><b>Pre-Consultation on Mechanised Parking System Proposals <i>(continued from previous page)</i></b></p> <ul style="list-style-type: none"> <li>As there is a variety of mechanised parking systems in the market, it is possible that some of these systems do not fully comply with LTA's guidelines. For such cases, the systems will be evaluated based on its own merits during the pre-submission consultation with LTA.</li> </ul> </div>
		<div style="border: 1px solid gray; padding: 5px;"> <p><b><u>Mechanised Parking System</u></b></p> <ul style="list-style-type: none"> <li>To submit the detailed drawings and description for the type of mechanised parking system used in the proposal. Information on how the system operates, how cars are parked and retrieved from the system, average time taken for parking and retrieval, safety features, etc. shall be clearly illustrated.</li> <li>The type of mechanised parking system and all relevant requirements/ dimensions of the parking system such as platform size, maximum load, headroom clearance, allowable car dimensions, safety features, etc. shall be clearly indicated and endorsed on plan. Ensure that the dimensions and information endorsed on plan correspond with the mechanised parking system specification.</li> <li>The cross-sectional details of the parking platform showing the inner clear width of the platform, clear platform length and clear movement space between the structural supports. To ensure that the dimension for headroom clearance of minimum 2.2m and platform size of minimum 2.4m x 5.4m are cleared of obstructions e.g. structural supports, structural cage, wire rope/hoisting cable, motorised equipment, sliding gears, etc.</li> </ul> </div>
		<div style="border: 1px solid gray; padding: 5px;"> <p><b><u>Car Lifts</u></b></p> <ul style="list-style-type: none"> <li>To submit the type of car lift system and all relevant requirements/ dimensions of the car lift system such as internal cage size, width of the entrance and exit door, maximum load, headroom clearance, allowable car dimensions, minimum speed, minimum discharge capacity, queuing spaces, safety features, etc. shall be clearly indicated and endorsed on plan. Information on how to operate the car lifts (e.g. call-button or loop detector), sequence on how cars enter/exit the car lift, provision of safety devices, etc. should be clearly illustrated.</li> <li>The proposed car lift system shall comply with the guidelines for provision of car lifts in car parking places.</li> </ul> </div>

## Others

	Agency	Requirement Category
	BCA	<div style="border: 1px solid gray; padding: 5px;"> <p><b><u>Complex Building Requirements</u></b></p> <ul style="list-style-type: none"> <li>Pre-submission consultation of structural concept on structural works involving complex building to be carried out during / after Design Gateway (G1) but prior to Piling Gateway (G1.5) or Construction Gateway (G2)</li> </ul> </div>
	URA	<div style="border: 1px solid gray; padding: 5px;"> <div style="border: 1px solid gray; padding: 5px; margin-bottom: 10px;"> <p><b><u>Built Environment Transformation Bonus GFA Incentive</u></b></p> <ul style="list-style-type: none"> <li>Submission of incentive scheme application and supporting documents</li> </ul> </div> <p><b><u>Pre-DG Submission: Stage 1 Design Advisory Panel – for selected projects</u></b></p> <ul style="list-style-type: none"> <li>The DAP materials submitted are to consist of:                             <ul style="list-style-type: none"> <li>Technical drawings (including a full set of plans, elevations and sections)</li> <li>Digital and hardcopy DAP booklets (including 2 hardcopies in A3), which should not exceed 50 pages, including appendices, attached drawings and plans, with a minimum font size of 12.</li> <li>Presentation slides. The number of presentation slides should be comfortable for a 20-minute presentation without lengthy text, highlighting the key points with further elaboration provided in the DAP booklet.</li> <li>Digital models</li> <li>Where necessary, a physical model of the proposed development will be required, at scale of 1:400 or smaller (to be advised by the officer in charge), showing context of site] will have to be submitted.</li> <li>Additional reports, such as Conservation Reports, are to be included as Appendices to the A3 booklets.</li> </ul> </li> </ul> </div>



## Pre-Submission, Planning and Other Consultations

Legend:



Architecture



C&S



M&E

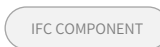

IFC COMPONENT

### Others (continued from previous page)

Agency	Requirement Category
URA	<p><b>Pre-DG Submission: Stage 1 Design Advisory Panel – for selected projects (continued from previous page)</b></p> <ul style="list-style-type: none"> <li>The following aspects of the proposal will be assessed at this stage of the DAP:                             <ul style="list-style-type: none"> <li>Stage 1 (Pre-DG DAP)                                     <ul style="list-style-type: none"> <li>Design Philosophy / Concept</li> <li>Form and Massing</li> <li>General architectural treatment (roofscape, façade in relation to context)</li> <li>Pedestrian Network and Vehicular Access</li> <li>Public Spaces and Landscape Replacement Areas / landscaping concepts</li> </ul> </li> </ul> </li> </ul>

### Submission to be done outside of CORENET X

Agency	Requirement Category
MHA/SPF	<p><b>Special Requirements</b></p> <ul style="list-style-type: none"> <li>Compliance with Security By Design (SBD) requirements, if applicable. Applicants may refer to the SBD criteria and requirements at the following website: <a href="https://www.corenet.gov.sg/media/2268551/implementation-of-ipa-to-enhance-building-security_corenetv6march.pdf">https://www.corenet.gov.sg/media/2268551/implementation-of-ipa-to-enhance-building-security_corenetv6march.pdf</a></li> </ul>
CAAS/DSTA	<p><b>Height Control Requirements</b></p> <p>Project teams should take into consideration the technical height controls administered by CAAS and DSTA, as part of their upstream design study, before proceeding to make their formal submissions in CORENET X. This will help to avoid abortive work and design changes downstream. For details, please refer to the Circular to Professional Institutes titled JOINT IACC-CAAS-RSAF ADVISORY (Ref: APPBCA-2023-10) released on 01 Jun 2023.</p> <p>Prior to submission at Construction Gateway, Applicants may engage CAAS and/or DSTA directly for clearance with the detailed design.</p>

----- **End of Requirements for Pre-Submission, Planning and Other Consultations** -----



## Design Gateway

Agency	Summary of Design Gateway Requirements	Common Gateway Key Words
<b>BCA</b>	<p>NIL</p> <p>Note: If building design involves complex buildings, consultation with BCA to be held before Piling Gateway (G1.5).</p>	-
<b>LTA</b>	<p>Compliance to traffic operations and safety requirements.</p> <p><b>Key Evaluation Areas include:</b></p> <ul style="list-style-type: none"> <li>• Location and provision of access points, pick-up/drop-off and loading/unloading area</li> <li>• Parking provision and layout</li> <li>• Extent of frontage improvement</li> <li>• Improvement needed to existing traffic scheme</li> <li>• Adequacy of connection to commuter facilities</li> <li>• Vesting of road reserve plot, if any</li> </ul> <p>For proposed new street, horizontal and vertical alignment, road typology and connection to existing road shall be established to determine the Road Reserve Line required.</p> <p>For proposed/relocation of commuter facilities, architectural layout to be evaluated to establish alignment, headroom and column positions, along with declaration to non-compliance with LTA’s standards and requirements (if any).</p> <p>Railway protection details should be provided to facilitate the review of the QP’s assessment of the overall impact of the development with respect to the RTS, including:</p> <ul style="list-style-type: none"> <li>• Plan for development works</li> <li>• Engineering evaluation report</li> <li>• Certified survey plans etc.</li> </ul>	<ul style="list-style-type: none"> <li>• External Works</li> <li>• Impact Studies</li> <li>• Infra &amp; Utilities (External)</li> <li>• Rail Protection</li> <li>• Site Layout</li> <li>• Street Works</li> <li>• Vehicular Parking</li> </ul>
<b>NEA</b>	<p><b>Compliance with pollution control and environmental health requirements, including:</b></p> <ul style="list-style-type: none"> <li>• Refuse and recyclables collection, storage and removal</li> <li>• Analysis of how surrounding developments/amenities affect subject site</li> <li>• Proposed orientation and location of emission (noise, air and odour) sources and ventilation/discharge systems within and around subject site</li> <li>• Location for storage for materials such as chemical, oil, fuel, etc.</li> <li>• Industrial processes or production activities or changes to existing activities</li> <li>• Building Height Constraint (BHC) and Minimum Chimney Height (MCH) requirements as stated in SS593</li> <li>• Energy Efficiency Opportunities Assessment (EEOA) declaration for industrial development</li> </ul> <p>Reports for Pollution Control Study/Air Dispersion Model Study, Quantitative Risk Assessment, Noise Impact Assessment, Environmental Site Assessment etc. may be submitted separately</p>	<ul style="list-style-type: none"> <li>• Building Massing</li> <li>• Impact Studies</li> <li>• Noise Control</li> <li>• Pollution Control</li> <li>• Public Health</li> <li>• Servicing (Internal Accesses)</li> <li>• Site Layout</li> <li>• Use &amp; Intensity</li> </ul>

See also:  
[Latest CORENET X Circulars](#)





## Design Gateway

Agency	Summary of Design Gateway Requirements <i>(continued from previous page)</i>	Common Gateway Key Words
<b>NParks</b>	<p>Greenery provision and tree conservation for developments, and the impact to existing, or provision of new, park / park connector.</p> <p><b>Provision of:</b></p> <ul style="list-style-type: none"> <li>• Details indicating spatial provision for greenery (i.e. width and depth of planting areas and green verges)</li> <li>• Information of trees/plants to be conserved (i.e. species, girth, height along roadside and/or within development boundary)</li> <li>• Entrance position(s), fire engine accessways, open air parking areas at street level and other structures (such as covered linkways and pedestrian overhead bridges) etc.</li> </ul> <p>For provision of new park/park connector/promenade, conceptual design to be reviewed early</p>	<ul style="list-style-type: none"> <li>• Greenery</li> <li>• Impact Studies only</li> <li>• Site Layout only</li> </ul>
<b>PUB</b>	<p>Broad planning parameters of drainage, sewerage and sanitary works (e.g. Minimum Platform Level, maximum allowable peak runoff, sewer setback, connection to public sewer etc.)</p> <p><b>Key Evaluation Areas include:</b></p> <ul style="list-style-type: none"> <li>• Storm water drainage works, erection or placement of any structures or objects in, above or across any drain or drainage reserve</li> <li>• Temporary structure/works/services over, across or adjacent to any drain or storm water drainage system</li> <li>• Proposed realignment of Drainage Reserve or Drainage Reserve to be set aside and vested to State</li> <li>• Works which could affect any public sewers/sewerage system or public drains including common drains directly or indirectly;</li> <li>• Buildings or structures to be erected over, across or adjacent to any public sewerage system;</li> <li>• Proposed connection of the development/premises to the public sewers/sewerage system</li> </ul>	<ul style="list-style-type: none"> <li>• ABC Waters</li> <li>• Detention System</li> <li>• Drainage Reserve</li> <li>• Earthworks / Topography</li> <li>• Infra &amp; Utilities (External)</li> <li>• Infra &amp; Utilities (Internal)</li> <li>• Platform &amp; Crest Level</li> <li>• Public Drains (External)</li> <li>• Public Drains (Internal)</li> <li>• Public Sewerage System</li> <li>• Sanitary</li> <li>• Site Layout only</li> </ul>
<b>SCDF</b>	<p>Note: Location of fire engine accessway and hard standing area to be included</p>	<ul style="list-style-type: none"> <li>• Fire Engine Accessway / Access Road</li> </ul>
<b>URA</b>	<p>Schematic details of key planning parameters (e.g. Masterplan (MP) land use/height/intensity) pertaining to the overall building form, site layout, how development relates to surroundings e.g. connectivity provisions</p> <p>Note: Where there are deviations to MP zoning controls, applicants should submit an Outline ahead of Design Gateway, where rezoning (if supported) can be carried out prior.</p>	<ul style="list-style-type: none"> <li>• Access to Site</li> <li>• Building Massing</li> <li>• Common Services Tunnel</li> <li>• Connectivity</li> <li>• Conservation</li> <li>• Earthworks / Topography</li> <li>• External Works</li> <li>• Greenery</li> <li>• Infra &amp; Utilities (Internal) only</li> <li>• Landscape Deck</li> <li>• Platform &amp; Crest Level</li> <li>• Public Space</li> <li>• Rapid Transit System (RTS) Station</li> <li>• Service and Vehicular Access to Site</li> <li>• Site Layout</li> <li>• Use &amp; Intensity</li> <li>• Vehicular Parking</li> <li>• Others</li> </ul>

# G1 Design Gateway

Legend:  Architecture  C&S  M&E IFC COMPONENT

ABC Waters	
Agency	Requirement Category
PUB	<p><b>ABC Waters Design Features</b></p> <p>To show conceptual plan endorsed by ABCWP (landscape Architect) or ABCWP (Architect) which includes:</p> <ul style="list-style-type: none"> <li>• Overall catchment plan (e.g., sub- catchment area, treatment area for proposed ABC Waters design features, land status and demarcation of site boundary, green buffer DR, RR etc.)</li> <li>• Overall layout plan (e.g., location of proposed ABC Waters features (indicative location of overflow sump within the feature), how it links with the proposed and existing drainage infra i.e., location of inlet and discharge point)</li> <li>• Detention volume to be provided by proposed ABC Waters design features to satisfy requirements as stipulated in 7.1.5 of the Code of Practice on Surface Water Drainage (if any)*</li> </ul>
Access to Site	
Agency	Requirement Category
URA <div style="border: 1px solid gray; border-radius: 10px; padding: 2px; width: fit-content; margin: 5px;">ROAD</div> <div style="border: 1px solid gray; border-radius: 10px; padding: 2px; width: fit-content; margin: 5px;">SLAB</div>	<p><b>Site Layout</b></p> <ul style="list-style-type: none"> <li>• Indicative locations of Pedestrian, Cycling, Vehicular and Service Access</li> </ul>
Allowable Structures within Planting Areas	
Agency	Requirement Category
NParks	<ul style="list-style-type: none"> <li>• Planting areas are free from any encroachment, except for allowable minor ancillary structures and landscaping structures as listed in NParks' Guidelines (Chapter 3). To show the allowable structures within planting areas.</li> </ul>
Building Massing	
Agency	Requirement Category
URA <div style="border: 1px solid gray; border-radius: 10px; padding: 2px; width: fit-content; margin: 5px;">BUILDING STOREY</div> <div style="border: 1px solid gray; border-radius: 10px; padding: 2px; width: fit-content; margin: 5px;">SPACE</div>	<p><b>Building Form and Massing</b></p> <ul style="list-style-type: none"> <li>• Development Statement of Intent (DSI) – Response to site context</li> <li>• Façade articulation and urban veranda (Orchard Road only)</li> </ul> <p><b>Building Height</b></p> <ul style="list-style-type: none"> <li>• Floor-to-Floor Height &amp; Aggregate Building Height               <ul style="list-style-type: none"> <li>○ Number of Storeys</li> <li>○ Additional Height for Predominant Sky Terrace Storey</li> </ul> </li> <li>• Overall Building Height Control (incl. building crown and M&amp;E floor, if any)</li> </ul> <p><b>Building Edge</b></p> <ul style="list-style-type: none"> <li>• Alignment of building edge and percentage of building form articulation</li> <li>• Height of building edge</li> <li>• Depth of building edge</li> </ul>

# G1 Design Gateway

Legend:  Architecture  C&S  M&E IFC COMPONENT

Common Services Tunnel (CST)	
Agency	Requirement Category
URA	<p><b>CST Integration</b></p> <ul style="list-style-type: none"> <li>Integration of CST ancillary structures such as ventilation shaft, entrance, exit &amp; any space dedicated to CST functions – Layout, alignment, notional work sequence, airflow calculations</li> <li>Link Chamber to CST junction box – Layout, services connection details</li> <li>Alteration of CST manholes or installation mouths - Layout and Alignment</li> </ul>

Connectivity	
Agency	Requirement Category
<p>URA</p> <div style="border: 1px solid gray; border-radius: 10px; padding: 5px; margin-bottom: 5px; text-align: center;">SITE BOUNDARY</div> <div style="border: 1px solid gray; border-radius: 10px; padding: 5px; margin-bottom: 5px; text-align: center;">SPACE</div> <div style="border: 1px solid gray; border-radius: 10px; padding: 5px; margin-bottom: 5px; text-align: center;">RAMP</div> <div style="border: 1px solid gray; border-radius: 10px; padding: 5px; margin-bottom: 5px; text-align: center;">PARKING LOT</div>	<p><b>Pedestrian Network</b></p> <p>Through Block Link (TBL), Underground Pedestrian Link (UPL), Elevated Pedestrian Link (EPL), Covered Walkways (CW), Open Walkways (OW), Covered Linkways (CL), High Covered Linkways (HCL)</p> <ul style="list-style-type: none"> <li>Layout and connections to existing / future developments</li> <li>Alignment to adjacent pedestrian connections</li> <li>Proposed levels and mitigation of level differences (if any)</li> <li>Soffit height, overall width and clear width</li> <li>Vehicular ramps to start after these Pedestrian Networks</li> </ul> <p>Additional requirements for the following:</p> <ul style="list-style-type: none"> <li>(UPL, EPL) Detailed layout of vertical circulation point – location within development, and dimensions</li> <li>(UPL, EPL) Knock Out Panels (KOP) details (e.g. alignment, size) where relevant</li> </ul> <p><b>Walking and Cycling Plan</b></p> <ul style="list-style-type: none"> <li>Connectivity to transport node</li> <li>Provision of measures to prevent conflict between pedestrian, cyclists and motor vehicles</li> <li>Provision of bike parking and supporting amenities (i.e. shower facilities and lockers)</li> </ul>

Conservation	
Agency	Requirement Category
URA	<a href="#">Refer to URA Conservation Requirements here</a>

Detention System	
Agency	Requirement Category
<p>PUB</p> <div style="border: 1px solid gray; border-radius: 10px; padding: 5px; margin-top: 10px; text-align: center;">SPACE</div>	<p><b>Peak Run Off</b></p> <ul style="list-style-type: none"> <li>Key Objective: To demonstrate how this is catered for, area is set aside for detention tank provision, location, OR drain widening</li> <li>Calculation of peak run off factor (C value) max. 0.55 (based on code and chart) e.g. area of development of greenfield site</li> </ul>

**G1 Design Gateway**

Legend:  Architecture  C&S  M&E IFC COMPONENT

Earthworks / Topography	
Agency	Requirement Category
PUB <span style="border: 1px solid gray; border-radius: 10px; padding: 2px 5px; display: inline-block;">SPACE</span>	<b><u>Earthworks</u></b> <ul style="list-style-type: none"> <li>Minimum Platform Level / Changes to Topography</li> </ul>
URA <span style="border: 1px solid gray; border-radius: 10px; padding: 2px 5px; display: inline-block;">WALL</span>  <span style="border: 1px solid gray; border-radius: 10px; padding: 2px 5px; display: inline-block;">EARTHWORKS</span>	<b><u>Earthworks, Retaining Walls and Boundary Walls</u></b> <ul style="list-style-type: none"> <li>Height of retaining wall(s), extent of earth-fill and impact on surroundings where relevant</li> </ul>
	<b><u>Earthworks, Platform Level</u></b> <ul style="list-style-type: none"> <li>Minimum Platform Level / Changes to site topography</li> </ul>
NParks	<b><u>Earthworks, Platform Level</u></b> <ul style="list-style-type: none"> <li>Changes to platform level and site topography</li> <li>Extent of earth-fill/earth-cut and impact to surroundings where relevant</li> </ul> <b><u>Conservation of Trees</u></b> <ul style="list-style-type: none"> <li>To conserve trees identified:                             <ul style="list-style-type: none"> <li>In Technical Conditions of Tender (TCOT)</li> <li>As Heritage Trees</li> <li>Through nature group / public / residents engagement</li> <li>In Environmental Impact Assessments (EIA) / Environmental Management and Monitoring Plans (EMMP) etc.</li> </ul> </li> </ul> <b><u>Supporting Document(s):</u></b> <ul style="list-style-type: none"> <li>a) Arborist report (Please refer to NParks' Guidelines [Chapter 2])</li> </ul>

External Works	
Agency	Requirement Category
URA <span style="border: 1px solid gray; border-radius: 10px; padding: 2px 5px; display: inline-block;">SPACE</span>	<b><u>Linkway Connection to Commuter Facilities</u></b> <ul style="list-style-type: none"> <li>Indicative alignment</li> <li>Connection through existing / future development</li> <li>Soffit height, overall width and clear width</li> <li>Proposed levels and mitigation of level differences (if any)</li> </ul>
URA <span style="border: 1px solid gray; border-radius: 10px; padding: 2px 5px; display: inline-block;">SPACE</span>	<b><u>Cycling Path</u></b> <ul style="list-style-type: none"> <li>Provision according to safeguarded cycling plan</li> <li>Indicative location of bicycle parking and supporting amenities (i.e. shower facilities and lockers) and declared GFA</li> </ul>
	<b><u>Promenade Guidelines (UD requirements for Singapore River)</u></b> <ul style="list-style-type: none"> <li>Location of walkways and landscaping</li> </ul>

# G1 Design Gateway

Legend:  Architecture  C&S  M&E IFC COMPONENT

## Fire Engine Accessway / Access Road

Agency	Requirement Category
<p>SCDF</p> <div style="display: flex; justify-content: space-around; align-items: flex-start;"> <div style="border: 1px solid gray; border-radius: 10px; padding: 2px 5px; margin-bottom: 5px;">ROAD</div> <div style="border: 1px solid gray; border-radius: 10px; padding: 2px 5px;">SITE BOUNDARY</div> </div> <div style="display: flex; justify-content: space-around; align-items: flex-start; margin-top: 5px;"> <div style="border: 1px solid gray; border-radius: 10px; padding: 2px 5px; margin-bottom: 5px;">SPACE</div> </div> <div style="display: flex; justify-content: space-around; align-items: flex-start;"> <div style="border: 1px solid gray; border-radius: 10px; padding: 2px 5px; margin-bottom: 5px;">WINDOW</div> </div>	<p><b>Fire Engine Accessways / Access Road</b></p> <ul style="list-style-type: none"> <li>To design upfront and not added as an afterthought</li> <li>Compliance of provision of fire engine accessway / access road does not affect the requisite planting areas and roadside green verges</li> <li>Indication of all the fire engine access road and accessway within project boundary</li> <li>Clearly indicate if public road is used as fire engine accessway / access road</li> <li>Compliance of width of fire engine accessway</li> <li>Compliance of distance between fire engine accessway and fire access opening</li> <li>Compliance of no obstruction between fire engine accessway and fire access opening</li> </ul>

## Greenery

Agency	Requirement Category
<p>NParks</p> <div style="border: 1px solid gray; border-radius: 10px; padding: 2px 5px; margin: 10px auto; width: 80%;">LANDSCAPE PLANTS</div>	<p><b>Conservation of Trees</b></p> <ul style="list-style-type: none"> <li>To conserve trees identified:                             <ul style="list-style-type: none"> <li>In Technical Conditions of Tender (TCOT)</li> <li>As Heritage Trees</li> <li>Through nature group / public / residents engagement</li> <li>In Environmental Impact Assessments (EIA) / Environmental Management and Monitoring Plans (EMMP) etc.</li> </ul> </li> </ul> <p> <b>Supporting Document(s):</b></p> <p>a) Arborist report (Please refer to NParks' Guidelines [Chapter 2])</p>
<p>URA</p> <div style="display: flex; justify-content: space-around; align-items: flex-start;"> <div style="border: 1px solid gray; border-radius: 10px; padding: 2px 5px; margin-bottom: 5px;">PLANTING AREA</div> <div style="border: 1px solid gray; border-radius: 10px; padding: 2px 5px;">PLANTER BOX</div> </div> <div style="border: 1px solid gray; border-radius: 10px; padding: 2px 5px; margin-top: 5px; width: 80%;">SPACE</div>	<p><b>Landscape Provision</b></p> <ul style="list-style-type: none"> <li>Landscape Replacement Area (LRA) requirements : There is no need to provide details of LRA computation in the Design Gateway plans/models. QPs should factor in the LRA requirements as part of their design at the onset and provide the details that will be checked at Construction Gateway</li> <li>Landscape Provision: Indicative Extent</li> <li>Indicative location of Sky Terrace / Planter Boxes / Covered Communal Ground Garden / Communal Pavilions</li> </ul>

## Impact Studies only

Agency	Requirement Category
<p>NEA</p>	<p> <b>Environmental Impact Study (EIS-Pre)</b></p> <p>EIS (Pre) report will be required for developments or infrastructure that would have environmental impact (air, water, land or noise) or affected by environmental impact. For example, new residential / sensitive developments located within 50m from new / existing petrol stations and/or new petrol stations located within 50m from existing residential/sensitive sites</p> <div style="display: flex; justify-content: space-between;"> <div style="width: 45%;"> <p><b>When to apply:</b></p> <ul style="list-style-type: none"> <li>Applicants are required to submit EIS (Pre) to NEA directly at Pre-Submission</li> <li>If Pre-Submission is not possible, the EIS (Pre) process should be concluded by Design Gateway (G1)</li> </ul> </div> <div style="width: 45%;"> <p><b>Who to submit:</b></p> <ul style="list-style-type: none"> <li>QP appointed should submit the above information and keep other relevant QPs in the loop.</li> <li>The same QP should follow through the submissions for all gateways.</li> </ul> </div> </div>

**G1**

# Design Gateway

Legend:



Architecture





C&S

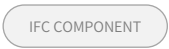

M&E



IFC COMPONENT



Impact Studies only	
Agency	Requirement Category
	<p> <b>Noise Impact Assessment (NIA-Pre) for Land Traffic Noise</b></p> <p>NIA (Pre) report will be required for (1) <u>New</u> residential and noise sensitive developments located within 70m of <u>existing</u> land traffic noise sources/hotspots (e.g. expressways / major arterial roads / MRT tracks) on existing residential and (2) <u>Existing</u> noise sensitive developments located within 70m of <u>new</u> transport-related developments (e.g. expressway/major arterial roads / MRT tracks / bus interchanges / bus depots), inclusive of the expansion of existing transport-related infrastructures</p> <p><b>When to apply:</b></p> <ul style="list-style-type: none"> <li>Applicants are required to submit NIA (Pre) report to NEA directly via email to <a href="mailto:DCLD_consultation@nea.gov.sg">DCLD_consultation@nea.gov.sg</a> at Pre-Submission and should be concluded by Design Gateway (G1)</li> <li>However, applicant may submit NIA (Pre) report to NEA directly at Construction Gateway (G2) if the development does not require any Design Gateway (G1) submission</li> <li>Sufficient time shall be catered for NEA to process the NIA (Pre)</li> <li>The processing of NIA (Pre) will take 1-2 months</li> </ul> <p><b>Who to submit:</b></p> <ul style="list-style-type: none"> <li>QP appointed should submit the above information and keep other relevant QPs in the loop.</li> <li>The same QP should follow through the submissions for all gateways.</li> </ul>
	<p> <b>Energy Efficiency Opportunities Assessment (EEOA) for New Ventures</b></p> <p>EEOA will be required for new industrial facilities and major expansions of existing facilities with an estimated annual energy consumption (AEC) <math>\geq 54TJ</math> must review the facility design and develop economically feasible for energy efficiency opportunities</p> <ul style="list-style-type: none"> <li>Applicants are required to submit EEOA report to NEA directly via email to <a href="mailto:DCLD_consultation@nea.gov.sg">DCLD_consultation@nea.gov.sg</a>. <ul style="list-style-type: none"> <li>EEOA-lite report before Design Gateway (G1) - Identification of energy efficiency recommendations at concept stage</li> <li>The full EEOA reports which include details such as the Front-End Engineering Design (FEED) can be submitted later at Construction Gateway</li> </ul> </li> </ul> <p><b>When to apply:</b></p> <ul style="list-style-type: none"> <li>Applicants are required to submit EEOA to NEA directly at Pre-Submission</li> <li>If Pre-Submission is not possible, the EEOA process should be concluded by Design Gateway (G1)</li> </ul> <p><b>Who to submit:</b></p> <ul style="list-style-type: none"> <li>QP appointed should submit the above information and keep other relevant QPs in the loop.</li> <li>The same QP should follow through the submissions for all gateways.</li> </ul>
	<p> <b>Environmental Site Assessment (ESA)</b></p> <p>ESA should be conducted when a site that is used for polluting activities is to be redeveloped, rezoned or reused for a non-polluting activity</p> <p><b>When to apply:</b></p> <ul style="list-style-type: none"> <li>Applicants should conclude the ESA at Pre-Submission</li> </ul> <p><b>Who to submit:</b></p> <ul style="list-style-type: none"> <li>QP appointed should submit the above information and keep other relevant QPs in the loop.</li> <li>The same QP should follow through the submissions for all gateways.</li> </ul>

**G1**

# Design Gateway

Legend:  Architecture  C&S  M&E IFC COMPONENT

**Impact Studies only** *(continued from previous page)*

	Agency	Requirement Category
	NEA <i>(continued from previous page)</i>	<p> <b>Pollution Control Study (PCS)</b></p> <p>Any proposed industrial development that could cause serious or substantial pollution of the environment, if mismanagement, is required to conduct a Pollution Control Study (PCS)</p> <ul style="list-style-type: none"> <li>Applicants are required to submit PCS-lite report to NEA directly via email to <a href="mailto:DCLD_consultation@nea.gov.sg">DCLD_consultation@nea.gov.sg</a> at Pre-Submission</li> <li>If Pre-Submission is not possible, the PCS-lite process should be concluded by Design Gateway (G1)</li> <li>PCS-lite submitted shall include:                             <ol style="list-style-type: none"> <li>Air pollution (affecting Chimney and Building height)</li> <li>Noise pollution from outdoor noisy equipment for factory premises</li> </ol> </li> </ul> <p><b>When to apply:</b></p> <ul style="list-style-type: none"> <li>Applicants are required to submit PCS report to NEA directly at Pre-Submission</li> <li>If Pre-Submission is not possible, the PCS process should be concluded by Design Gateway (G1)</li> </ul> <p><b>Who to submit:</b></p> <ul style="list-style-type: none"> <li>QP appointed should submit the above information and keep other relevant QPs in the loop.</li> <li>The same QP should follow through the submissions for all gateways.</li> </ul>
		<p> <b>Quantitative Risk Assessment (QRA)</b></p> <ul style="list-style-type: none"> <li>Anyone intending to store or use hazardous substances will have to pre-consult MOM-MHD whether a QRA assessment is required.</li> </ul> <p><b>When to apply:</b></p> <ul style="list-style-type: none"> <li>If QRA is required, applicants are required to submit QRA report to MOM-MHD for dissemination to respective agencies (including NEA).</li> <li>The QRA report should be accepted by agencies before Design Gateway (G1)</li> </ul> <p><b>Who to submit:</b></p> <ul style="list-style-type: none"> <li>QP appointed should submit the above information and keep other relevant QPs in the loop.</li> <li>The same QP should follow through the submissions for all gateways.</li> </ul>
	NParks	<p> <b>Biodiversity Impact Assessment (under URA's Environmental Impact Assessment [EIA] framework)</b></p> <ul style="list-style-type: none"> <li>Applicable to sites that fall within the EIA Framework but were not identified at Planning Stage (Pre-DG)                             <ul style="list-style-type: none"> <li><u>Environmental Consultation</u> <ul style="list-style-type: none"> <li>QP (Arch / PEs) or Consultant to submit the environmental consultation form (Form A) to URA and Technical Agencies (e.g. NEA, NParks, MPA, SFA)</li> <li>Details of project entities (Developer, Qualified Person and Main Contractor) as stated in Form A are provided</li> </ul> </li> <li><u>Environmental Impact Assessment (EIA)</u> <ul style="list-style-type: none"> <li>If determined during environmental consultation that an environmental study is needed, QP (Arch / PEs) or Consultant can consult on environmental baseline study and scoping of EIA</li> <li>QP (Arch / PEs) or Consultant to ensure that EIA report (for projects that have cleared environmental assessment at planning stage) are submitted for acceptance</li> </ul> </li> </ul> </li> </ul>

**Impact Studies, Site Layout, Rail Protection**

	Agency	Requirement Category
	LTA	<p> <b>Development Proposal within Railway Protection Zone / Railway Corridor</b></p> <ul style="list-style-type: none"> <li>To show the proposed plan for development works</li> <li>To provide an engineering evaluation report accompanied by a plan for engineering works</li> <li>To furnish the relevant Certified Survey Plans (for critical development within first reserve of underground RTS)</li> </ul>

# G1 Design Gateway

Legend:  Architecture  C&S  M&E IFC COMPONENT

## Impact Studies, Site Layout, Rail Protection *(continued from previous page)*

	Agency	Requirement Category
	LTA	<p><b><u>Development Proposal within Railway Protection Zone / Railway Corridor <i>(continued from previous page)</i></u></b></p> <p> *If the QP deems the impact from the development to be negligible, an engineering assessment outlining the method of analysis, assumptions and projected impact to the RTS will suffice at this stage. This is subject to LTA's acceptance.</p> <p>Note: Refer to LTA's Code of Practice for Railway Protection / Guidebook for Carrying Out Modification Work to Rapid Transit System (RTS) Stations or Railway by Private Developer for more requirements / detailed description</p>

## Infra & Utilities (Internal) only

	Agency	Requirement Category
	PUB	<p><b><u>Drainage Network</u></b></p> <ul style="list-style-type: none"> <li>To show conceptual plan – location, proposed discharged point, connection to existing drainage network</li> </ul>
	URA	<p><b><u>Urban Design Requirements</u></b></p> <ul style="list-style-type: none"> <li>Integration of Utilities (e.g. MRT pop-up, substation, water bulk meter) into building envelope</li> </ul> <p><b><u>Basement pumped drainage system (stormwater tank)</u></b></p> <ul style="list-style-type: none"> <li>Location, volume</li> </ul> <p><b><u>Critical Infrastructure/Key Installation</u></b></p> <ul style="list-style-type: none"> <li>To show location of Distribution Sub-Station</li> </ul>

## Loading / Development Loading

	Agency	Requirement Category
	URA	<p><b><u>Loading Provisions</u></b></p> <ul style="list-style-type: none"> <li>Alignment and locations of loading columns</li> <li>Structural system and integration with future structures (e.g. location / orientation / size of vents)</li> <li>Loading calculations</li> <li>(EPL) Loading provision to receive future linkways / walkways (if any)</li> </ul> <p> <b><u>Supporting Documents:</u></b></p> <ol style="list-style-type: none"> <li>Draft Development Interface Report for future developer</li> <li>Clearance from technical agencies</li> </ol>

## Night Lighting

	Agency	Requirement Category
	URA	<p> <b><u>Night Lighting Report</u></b></p> <ol style="list-style-type: none"> <li>UD Areas with night lighting requirement</li> <li>Concept and Renders, Location and Extent</li> </ol>



# G1 Design Gateway

Legend:  Architecture  C&S  M&E IFC COMPONENT

ORA / ODA / Kiosks	
Agency	Requirement Category
URA	<ul style="list-style-type: none"> <li>Location and extent, key parameters (e.g. structure, height, transparency)</li> </ul>

Platform & Crest Level only	
Agency	Requirement Category
PUB <span style="border: 1px solid gray; border-radius: 10px; padding: 2px 5px; display: inline-block;">SPACE</span>	<p><b><u>Minimum Platform Level, Crest Level</u></b></p> <ul style="list-style-type: none"> <li>SHD</li> <li>Adjacent Road Levels</li> </ul> <p><b><u>Flood Protection Measures</u></b></p> <ul style="list-style-type: none"> <li>If crest level is not provided - location and height of protection measure</li> </ul>

Public Drains (Internal)	
Agency	Requirement Category
PUB <span style="border: 1px solid gray; border-radius: 10px; padding: 2px 5px; display: inline-block;">SYSTEM</span> <span style="border: 1px solid gray; border-radius: 10px; padding: 2px 5px; display: inline-block;">Civil Element</span>	<p><b><u>Common Drain</u></b></p> <p>(Drains receiving upstream run off / existing [note: more common for landed housing area])</p> <ul style="list-style-type: none"> <li>Location, width</li> </ul> <p><b><u>Internal Drain</u></b></p> <ul style="list-style-type: none"> <li>Location, width</li> <li>Discharge point</li> </ul>

Public Space	
Agency	Requirement Category
URA	<p><b><u>Privately-Owned Public Spaces (POPS)</u></b></p> <ul style="list-style-type: none"> <li>Indicate location, design and dimensions:                             <ul style="list-style-type: none"> <li>Location</li> <li>Size / height</li> <li>Layout / configuration</li> <li>Shadow Studies</li> <li>Seating provision</li> </ul> </li> <li>Activity Generating Uses:                             <ul style="list-style-type: none"> <li>Indicate location on plan and provide details on specific nature of use</li> </ul> </li> </ul>

Public Sewerage System (External)	
Agency	Requirement Category
PUB <span style="border: 1px solid gray; border-radius: 10px; padding: 2px 5px; display: inline-block;">SYSTEM</span>	<p><b><u>Sewer Connection</u></b></p> <ul style="list-style-type: none"> <li>Connection Point – where the proposed location is</li> </ul> <p><b><u>Sewerage System</u></b></p> <ul style="list-style-type: none"> <li>Alignment, size, setback, Invert Level, Top Level of existing public Sewers.</li> <li>Location, Top Level, Invert Level, Manhole ID of connecting Manhole</li> <li>Location of Hydraulic/Vortex Drop</li> </ul>

# G1 Design Gateway

Legend: ■ Architecture ■ C&S ■ M&E IFC COMPONENT

Rapid Transit System (RTS) Station	
Agency	Requirement Category
URA SPACE SITE SITE BOUNDARY ACCESSIBLE ROUTE	<p><b>Urban Design Requirements</b></p> <ul style="list-style-type: none"> <li>Lines of Road Reserve / Site boundary of adjacent land parcels</li> <li>Location of station box and its associated tunnels &amp; structures</li> <li>Land take required (footprint to be optimized to minimize the land-take)</li> <li>Details of Loading Provision (e.g. Loading grid plan)</li> <li>Design of pop-up &amp; ancillary structures (within approved railway, setback, mitigation of platform levels, interfacing with neighbouring developments, CW provision)</li> </ul> <p><b>Supporting Documents:</b></p> <ol style="list-style-type: none"> <li>Submission of RTS Checklist</li> <li>Method of construction (cut and cover , tunnel boring)</li> <li>Copy of the relevant approvals for the proposed retail quantum</li> </ol> <p><i>Note: Coordinated by the Architect, with inputs from respective engineers</i></p>

Roofscape	
Agency	Requirement Category
URA	<ul style="list-style-type: none"> <li>Location and extent of M&amp;E</li> <li>Location and extent of Outdoor Refreshment Area (ORA)</li> </ul>

Sanitary (Internal)	
Agency	Requirement Category
PUB DISTRIBUTION CHAMBER SANITARY APPLIANCES SYSTEM	<p><b>Indicative Location(s) of Drain-line and Inspection Chamber</b></p> <ul style="list-style-type: none"> <li>Location, Top Level and Invert Level of last Inspection Chamber.</li> <li>Location and Top level of remaining Inspection Chambers.</li> <li>Details (e.g. alignment) and Invert Level of Drain-line to be provided by M&amp;E in Construction Gateway (G2)</li> </ul> <p><b>Used Water Flow Rate</b></p> <ul style="list-style-type: none"> <li>Key Objective: To check that sewer can contain this flow</li> <li>Quantity &amp; flow rate expected to be discharged from development, where it is to be discharged (based on no. of toilets, shower head and floor traps - in relation to no. of DUs)</li> </ul>

Service and Vehicular Access to Site	
Agency	Requirement Category
URA ROAD SPACE	<p><b>Vehicular Access</b></p> <ul style="list-style-type: none"> <li>Location of vehicular, pedestrian and cyclist access points, and layout of internal driveways</li> <li>Integration with Building Envelope</li> </ul> <p><b>Service Areas</b></p> <ul style="list-style-type: none"> <li>Location and integration with building envelope</li> <li>Visual Screening</li> </ul>

**G1**

**Design Gateway**

Legend:  Architecture  C&S  M&E IFC COMPONENT

Site Layout only							
Agency	Requirement Category						
<p>NEA</p> <div style="margin-top: 5px;"> <span style="border: 1px solid gray; border-radius: 10px; padding: 2px 10px; display: inline-block; margin-bottom: 5px;">SITE</span> </div> <div style="margin-top: 5px;"> <span style="border: 1px solid gray; border-radius: 10px; padding: 2px 10px; display: inline-block; margin-bottom: 5px;">SPACE</span> </div> <div style="margin-top: 5px;"> <span style="border: 1px solid gray; border-radius: 10px; padding: 2px 10px; display: inline-block; margin-bottom: 5px;">REFUSE CHUTE</span> </div> <div style="margin-top: 5px;"> <span style="border: 1px solid gray; border-radius: 10px; padding: 2px 10px; display: inline-block; margin-bottom: 5px;">DOOR</span> </div> <div style="margin-top: 5px;"> <span style="border: 1px solid gray; border-radius: 10px; padding: 2px 10px; display: inline-block;">ROAD</span> </div>	<p><b><u>Environmental Information (EI)</u></b></p> <ul style="list-style-type: none"> <li>EI information such as building height constraint, health and safety buffer, etc. shall be incorporated in the building plan design to ensure that the development is able to meet the requirement.</li> </ul> <p><b>When to apply:</b></p> <ul style="list-style-type: none"> <li>Applicants are required to apply EI from NEA directly at Pre-Submission and incorporate the information in building plan submission in Design Gateway (G1)</li> <li>However, applicant may submit the above information at Pre-Submission if the development does not require any Design Gateway (G1)</li> </ul> <hr/> <p><b><u>Environmental Health (COPEH)</u></b></p> <ul style="list-style-type: none"> <li>Refuse Truck Access road (for refuse collection) – Swept Path Analysis</li> <li>Location and Size of the Bin Centre/Refuse Room/Bin Point, refuse chute and recycling chute, refuse chute chamber and recyclables storage &amp; its collection system</li> <li>Provide total daily refuse outputs (liters/day) for the development</li> <li>Location and dimensions of spatial provisions of Pneumatic waste conveyance system (PWCS) to meet the minimum requirements specified in Singapore Standard - Code of Practice for Pneumatic Waste Conveyance System (SS 642: 2019)</li> <li>Location of cooling tower and its setback distance (at least 5m)</li> </ul> <table style="width: 100%; border: none;"> <tr> <td style="vertical-align: top; width: 50%;"> <p><b>When to apply:</b></p> <ul style="list-style-type: none"> <li>Applicants should provide the above information (either in 2D, 3D or supporting documents) and should be concluded by Design Gateway (G1)</li> <li>However, applicant may submit the above information at Pre-Submission if the development does not require any Design Gateway (G1)</li> </ul> </td> <td style="vertical-align: top; width: 50%;"> <p><b>Who to submit:</b></p> <ul style="list-style-type: none"> <li>QP appointed should submit the above information and keep other relevant QPs in the loop.</li> <li>The same QP should follow through the submissions for all gateways.</li> </ul> </td> </tr> </table> <hr/> <p><b><u>Pollution Control (COPPC)</u></b></p> <ul style="list-style-type: none"> <li>Confirm the proposed development is aligned with the prevailing URA MP land use zoning (e.g. residential to residential)</li> <li>Building location and its surrounding development/amenities (such as expressway/major road, MRT/MRT station, place of worship, hospital, petrol station, industry premises etc.)</li> <li>Orientation and location of nuisance sources (e.g. cooling towers, chiller plants, air handling units, air conditioning condensers, fresh air intake, exhaust outlets (ventilation shaft), etc)</li> <li>50m nuisance buffer from place of worship, petrol station, Light industry premises to the nearest residential development.</li> <li>100m nuisance buffer from General industry premises to nearest residential development.</li> <li>500m nuisance buffer from Special Industry premises to nearest residential development.</li> <li>Orientation of building: Minimum building setback (m)</li> </ul> <table border="1" style="width: 100%; border-collapse: collapse; margin-bottom: 10px;"> <tr> <td style="padding: 2px 10px;">Fronting track</td> <td style="padding: 2px 10px; text-align: center;">35</td> </tr> <tr> <td style="padding: 2px 10px;">End-wall facing track</td> <td style="padding: 2px 10px; text-align: center;">25</td> </tr> </table> <ul style="list-style-type: none"> <li>Setback distance within 70m from transport-related infrastructure (i.e. LTA road reserve line for expressway/major road) to the nearest residential development Lot boundary line.</li> <li>Location of the chimney and BHC and MCH requirements e.g. within 30m / 100m radius of existing chimney stack height</li> <li>Location changes for the storage inventory product / materials such as chemical, oil, fuel, etc</li> </ul>	<p><b>When to apply:</b></p> <ul style="list-style-type: none"> <li>Applicants should provide the above information (either in 2D, 3D or supporting documents) and should be concluded by Design Gateway (G1)</li> <li>However, applicant may submit the above information at Pre-Submission if the development does not require any Design Gateway (G1)</li> </ul>	<p><b>Who to submit:</b></p> <ul style="list-style-type: none"> <li>QP appointed should submit the above information and keep other relevant QPs in the loop.</li> <li>The same QP should follow through the submissions for all gateways.</li> </ul>	Fronting track	35	End-wall facing track	25
<p><b>When to apply:</b></p> <ul style="list-style-type: none"> <li>Applicants should provide the above information (either in 2D, 3D or supporting documents) and should be concluded by Design Gateway (G1)</li> <li>However, applicant may submit the above information at Pre-Submission if the development does not require any Design Gateway (G1)</li> </ul>	<p><b>Who to submit:</b></p> <ul style="list-style-type: none"> <li>QP appointed should submit the above information and keep other relevant QPs in the loop.</li> <li>The same QP should follow through the submissions for all gateways.</li> </ul>						
Fronting track	35						
End-wall facing track	25						

**G1**

**Design Gateway**

Legend:



Architecture



C&S



M&E

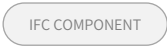

IFC COMPONENT

**Site Layout only** (continued from the previous page)

Agency	Requirement Category
<p>NEA</p> <p><i>(continued from the previous page)</i></p>	<p><b>Pollution Control (COPPC)</b> (continued from the previous page)</p> <ul style="list-style-type: none"> <li>Location changes for the storage inventory product / materials such as chemical, oil, fuel, etc</li> <li>Changes in the industrial processes or production activities location</li> <li>Changes of existing activity, expansion of existing activities or proposed new activity carried out on the proposed development or premises</li> </ul> <p><b>When to apply:</b></p> <ul style="list-style-type: none"> <li>Applicants should provide the above information (either in 2D, 3D or supporting documents) and should be concluded by Design Gateway (G1)</li> <li>However, applicant may submit the above information at Pre-submission if the development does not require any Design Gateway (G1)</li> </ul> <p><b>Who to submit:</b></p> <ul style="list-style-type: none"> <li>QP appointed should submit the above information and keep other relevant QPs in the loop.</li> <li>The same QP should follow through the submissions for all gateways.</li> </ul>
<p>NParks</p> <p>PLANTING AREA</p> <p>SITE BOUNDARY</p> <p>GREEN VERGE</p>	<p><b>Provision of Planting Areas</b></p> <ul style="list-style-type: none"> <li>To provide development boundary lines</li> <li>To provide existing and proposed road reserve lines</li> <li>To provide road name(s) and category of existing and proposed roads</li> <li>To provide planting areas (i.e. 3.0m/5.0m-wide green buffers, 2.0m-wide peripheral planting verges, open-air parking planting areas) in compliance with NParks' Guidelines (Chapter 3)</li> <li>To ensure planting areas are free from any encroachment, except for allowable minor ancillary structures and landscaping structures as listed in NParks' Guidelines (Chapter 3)</li> <li>To show the allowable structures within planting areas</li> <li>To locate fire engine accessways and non-allowable structures outside planting areas</li> <li>To recess underground structures / services at least 2.0m below planting areas, except for:                             <ul style="list-style-type: none"> <li>Footings of retaining / boundary walls (may encroach up to 0.5m into planting areas)</li> <li>Services traversing perpendicularly across planting areas</li> </ul> </li> <li>Applicants should provide the above information (either in 2D, 3D or supporting documents) and should be concluded by Design Gateway (G1)</li> </ul> <p><b>New Parks/ Park Connectors/ Promenades</b></p> <ul style="list-style-type: none"> <li>To ensure design is in accordance with NParks specifications (e.g., spatial provision, access points, specific features / elements imposed at planning stage based on NParks planning conditions)</li> </ul> <p><b>Securing of Land for Parks / Park Connectors use and/or Impact on Neighbouring Parks (e.g., en bloc sites)</b></p> <ul style="list-style-type: none"> <li>To ensure site boundary does not encroach into safeguarded / rezoned parks and park connectors</li> </ul> <p><b>Green Verges</b></p> <ul style="list-style-type: none"> <li>To provide green verges (consisting of tree planting and service verges) for street work proposals relating to development works and for new road services according to the road category</li> <li>To locate fire engine accessways outside green verges</li> <li><b>Road and Commuter Infrastructure</b> <ul style="list-style-type: none"> <li>To comply with greenery provision for covered linkways, bus shelters, pedestrian overhead bridges, depressed road portals, road viaducts/flyovers and retaining walls etc. according to NParks' Guidelines (Chapter 4)</li> </ul> </li> <li><b>Entrance Culvert Position (at Vehicular Access Points)</b> <ul style="list-style-type: none"> <li>To ensure splay corners do not affect green verge provision and roadside trees</li> </ul> </li> </ul>

# G1 Design Gateway

Legend: ■ Architecture ■ C&S ■ M&E IFC COMPONENT

Site Layout only <i>(continued from previous page)</i>	
Agency	Requirement Category
URA ROAD SITE SPACE SITE BOUNDARY	<p><b>Building Setback from Boundary</b></p> <ul style="list-style-type: none"> <li>Road Buffer</li> <li>Common Boundary Setback / Party wall &amp; Planting Strip</li> <li>Building Setback for Multi-Storey Car Parks (MSCP)</li> <li>Boundary Setback for Ancillary Structures</li> <li>Setback requirement for Urban Design areas</li> </ul> <p><b>Site Layout</b></p> <ul style="list-style-type: none"> <li>Location of Buildings</li> <li>Location and scale / size of Communal Facilities (e.g. bin centre, pavilions, BBQ areas)</li> </ul> <p><b>Site Coverage</b></p> <ul style="list-style-type: none"> <li>Site coverage computation</li> </ul>

Site Layout, Drainage Reserve	
Agency	Requirement Category
PUB	<p><b>Drainage Reserve</b></p> <ul style="list-style-type: none"> <li>Location (align to DIP), width</li> </ul> <p><i>Note: Coordinated by the Architect, with inputs from C&amp;S</i></p>

Site Layout, Landscape Deck	
Agency	Requirement Category
URA PLANTING AREA PLANTER BOX SPACE	<p><b>Landscape Deck</b></p> <ul style="list-style-type: none"> <li>Height of Deck in relation to Existing Ground levels</li> <li>Location and General Layout of Deck</li> </ul>

Site Layout, Street Works	
Agency	Requirement Category
LTA ROAD SPACE CULVERT RAMP	<p> <b>Development Proposal</b></p> <ul style="list-style-type: none"> <li>To check if project falls within LTA's exemption list and is not required to obtain a clearance from LTA DBC, i.e. LTA in-house project.</li> <li>To confirm if the development falls within a road structure safety zone (RSSZ).</li> </ul>

**G1 Design Gateway**

Legend:  Architecture  C&S  M&E IFC COMPONENT

**Site Layout, Street Works** (continued from the previous page)

Agency	Requirement Category
LTA  <i>(continued from the previous page)</i>  <div style="display: flex; flex-direction: column; gap: 5px;"> <div style="border: 1px solid gray; border-radius: 10px; padding: 2px 10px; text-align: center;">ROAD</div> <div style="border: 1px solid gray; border-radius: 10px; padding: 2px 10px; text-align: center;">SPACE</div> <div style="border: 1px solid gray; border-radius: 10px; padding: 2px 10px; text-align: center;">CULVERT</div> <div style="border: 1px solid gray; border-radius: 10px; padding: 2px 10px; text-align: center;">RAMP</div> </div>	<p><b><u>Connections and Interfaces at development boundary</u></b></p> <ul style="list-style-type: none"> <li>To indicate the road level, entrance culvert level, and the proposed development platform level.</li> <li>For new roads proposed in conjunction with development(s), to develop the development platform level and proposed levels of the development access points based on the vertical alignment of the proposed carriageway (before QP confirms on the development platform level for the design of the foundation / structural works).</li> <li>To show the gradient of entrance approach.</li> <li>To indicate the configuration of the proposed access.</li> <li>To indicate the width and turning radius of the proposed access.</li> <li>To indicate the provision of tactile tiles.</li> <li>To indicate any proposed relocation of existing road elements, such as trees, lamp post, signs etc, which may be affected by proposed access.</li> </ul> <hr/> <p><b><u>Vehicular Access Points</u></b></p> <ul style="list-style-type: none"> <li>To indicate the levels of entrance culvert and gradient of entrance approach</li> <li>To indicate the radius of turning road kerb</li> <li>To show the provision of tactile tiles and shifting of existing road elements (incl. trees, lamp post, signs, etc.) affected by proposed access</li> </ul> <hr/> <p><b><u>Proposed Pick-Up / Drop-Off Points (Within Development): PUDO Layout</u></b></p> <ul style="list-style-type: none"> <li>To show the location of the PUDO facility within the development site</li> <li>To mark out the number of PUDO bays and indicate the queue length</li> <li>Indicate width and kerb alignment of PUDO points</li> </ul> <hr/> <p><b><u>Proposed Loading / Unloading (Within Development): U/UL Layout</u></b></p> <ul style="list-style-type: none"> <li>To show the location of the U/UL facility</li> <li>To mark out the number of U/UL bays</li> </ul>



**Use & Intensity**

Agency	Requirement Category
URA  <div style="display: flex; flex-direction: column; gap: 5px;"> <div style="border: 1px solid gray; border-radius: 10px; padding: 2px 10px; text-align: center;">SPACE</div> <div style="border: 1px solid gray; border-radius: 10px; padding: 2px 10px; text-align: center;">SITE</div> <div style="border: 1px solid gray; border-radius: 10px; padding: 2px 10px; text-align: center;">SITE BOUNDARY</div> </div>	<ul style="list-style-type: none"> <li>Land Use / Building Uses - Provide breakdown by use quantum</li> <li>Gross Plot Ratio / Gross Floor Area computation</li> </ul> <hr/> <p><b><u>Bonus GFA Incentive Schemes:</u></b></p> <ul style="list-style-type: none"> <li>Balcony / Recreational / Built Environment Transformation / Others – GFA quantum and %</li> <li>Documentation to support proposed scheme (if required)</li> </ul> <hr/> <p><b><u>Site Boundary</u></b></p> <ul style="list-style-type: none"> <li>Site Area</li> <li>Land to be Vested for Public Schemes (Drain, Road, Open Space, Park, Cycling Paths)</li> <li>Land to be Amalgamated / Alienated</li> </ul> <hr/> <p><b><u>Dwelling Units</u></b></p> <ul style="list-style-type: none"> <li>Maximum Number</li> <li>Pre-Application Feasibility Study (together with LTA)</li> </ul>

**G1 Design Gateway**

Legend: ■ Architecture ■ C&S ■ M&E IFC COMPONENT

Vehicular Parking	
Agency	Requirement Category
LTA PARKING LOT SPACE RAMP DRIVEWAY	<p><b><u>Vehicular Parking Provision</u></b></p> <ul style="list-style-type: none"> <li>To comply fully with the prevailing Parking Places (Provision of Parking Places and Parking Lots) Rules and other relevant guidelines of the Authority</li> <li>To ensure that the number of parking lots provided is within the specified range defined by the lower and upper bound requirement. (The Range-based parking provision standard for the various development uses can be found in Annex A of the COP for Vehicle Parking Provision in Development Proposals)</li> <li>To ensure that the geometric dimensions of the parking layout complies with the standard minimum dimensions as stipulated in the COP</li> <li>To provide the details and critical dimensions of the parking layout as stipulated in the COP such as:                             <ul style="list-style-type: none"> <li>Type and size of parking lots</li> <li>Width of ramps and accessways</li> <li>Inner turning radius and width of turning paths</li> <li>Width of parking aisles</li> <li>Gradient of vehicular ramps</li> <li>Headroom clearance</li> <li>Road and traffic arrow markings</li> <li>Bicycle rack details</li> <li>Location of EV chargers</li> </ul> </li> </ul>
URA PARKING LOT SPACE	<p><b><u>Parking</u></b></p> <ul style="list-style-type: none"> <li>Show location within site</li> <li>Declare total number and breakdown of types</li> </ul>

Others	
Agency	Requirement Category
BCA	<p><b><u>Complex Building Requirements</u></b></p> <ul style="list-style-type: none"> <li>Pre-submission consultation of structural concept on structural works involving complex building to be carried out during/after Design Gateway (G1) but prior to Piling Gateway (G1.5) or Construction Gateway (G2)</li> </ul>
URA	<p> <b><u>Urban Design Requirements</u></b></p> <ul style="list-style-type: none"> <li>Submission of DA Checklist</li> </ul> <p> <b><u>Supplementary Documents</u></b></p> <ul style="list-style-type: none"> <li>Topo Survey Plan</li> <li>Previous approved plans (where requested by URA)</li> </ul> <p> <b><u>Public Communications Plan (if applicable)</u></b></p> <p>Non-Government Land Sales (GLS) Sites</p> <ul style="list-style-type: none"> <li>If Public Communications Plan is required, URA will inform at Design Gateway submission, for project team's follow up distribution of flyers to the local community and submission of relevant forms</li> </ul> <p>GLS sites</p> <ul style="list-style-type: none"> <li>Public Communications Plan requirements, if any, will be clearly set out in the tender conditions. Flyers should have been distributed to the local community, and relevant forms already submitted.</li> </ul>

**G1**

# Design Gateway

Legend:  Architecture  C&S  M&E IFC COMPONENT

Others	
Agency	Requirement Category
URA	<div style="display: flex; align-items: flex-start;"> <div style="border: 1px solid gray; padding: 2px; margin-right: 5px;">             ✓ ✓ ✓           </div> <div> <p><b>Development Statement of Intent</b></p> <ul style="list-style-type: none"> <li>Description of proposal (for relevant development types)</li> </ul> </div> </div>
	<div style="display: flex; align-items: flex-start;"> <div style="border: 1px solid gray; padding: 2px; margin-right: 5px;">             ✓ ✓ ✓           </div> <div> <p><b>RTS Checklist</b></p> <ul style="list-style-type: none"> <li>Submission of checklist for evaluation</li> </ul> </div> </div>
	<div style="display: flex; align-items: flex-start;"> <div style="border: 1px solid gray; padding: 2px; margin-right: 5px;">             ✓ ✓ ✓           </div> <div> <p><b>Environmental Impact Assessment (where required)</b></p> <ul style="list-style-type: none"> <li>If development projects are near to sensitive areas (such as Nature Reserves, Nature Areas, marine and coastal areas, other areas of significant biodiversity) or might have potential trans-boundary impacts, relevant technical agencies (such as the National Parks Board, National Environment Agency, Maritime and Port Authority of Singapore, and Singapore Food Agency) will need to be consulted more extensively to determine if a more thorough environmental study is required.</li> <li>For affected proposals, URA will provide project teams with further instructions on how to proceed with such consultations.</li> </ul> </div> </div>

**End of Requirements for Design Gateway (G1)** -----



**G1.5 Piling Gateway**

Agency	Summary of Piling Gateway Requirements	Common Gateway Key Words
	<b>* Piling Gateway is optional</b>	
<b>BCA</b>	<ul style="list-style-type: none"> <li>Piling &amp; Foundation Works IFC-SG model</li> <li><b>2D drawings limited to the categories below:</b> <ul style="list-style-type: none"> <li>General notes</li> </ul> </li> <li>Design calculation reports from QP, AC, [QP(Geo) &amp; AC (Geo), if needed]</li> <li><b>Additional supporting documents:</b> <ul style="list-style-type: none"> <li>Site investigation report in pdf &amp; AGS format</li> <li>Impact assessment report</li> <li>Topography</li> </ul> </li> <li>Complete set of structural framing plan for reference</li> <li>Complete set of building plan for reference</li> <li>Completion letter of pre-consultation [for complex structure only]</li> </ul>	<ul style="list-style-type: none"> <li>Structural Design</li> </ul>
<b>LTA</b>	<p><b>Railway Protection Details (if applicable):</b></p> <ul style="list-style-type: none"> <li>Plan for engineering works</li> <li>Engineering evaluation report</li> <li>Instrumentation proposal</li> <li>Method statement of work</li> <li>Emergency procedure</li> <li>Pre-condition survey report</li> <li>Certified survey plan, relevant forms etc.</li> </ul>	<ul style="list-style-type: none"> <li>Impact Studies</li> <li>Rail Protection</li> <li>Site Layout</li> </ul>
<b>NEA</b>	NIL	NIL
<b>NParks</b>	<p>Applicable to sites requiring Environmental Monitoring and Management Plan (EMMP) / wildlife management plan prior to commencement of works:</p> <ul style="list-style-type: none"> <li>No-objection/acceptance prior to site clearance</li> </ul>	NIL
<b>PUB</b>	<p><b>To apply separately for relevant works where applicable prior to commencement of works:</b></p> <ul style="list-style-type: none"> <li>Specified activities near water and sewer pipes</li> <li>Temporary works affect drainage/within drainage reserve etc.</li> </ul>	<ul style="list-style-type: none"> <li>Public Sewerage System (External)</li> </ul>
<b>SCDF</b>	NIL	NIL
<b>URA</b>	NIL	NIL

**Piling Gateway Clearances**

Works affecting Permanent Structures

- BCA's ST Approvals for Piling & Relevant Substructure Works
- LTA's Approval in-principle (AIP) for Pile Design and Pile Layout Plan (only within the Railway Protection Zone)

**Parallel Processes**  
 (Other clearances to be obtained before commencement of respective works)

**Site Clearance**

- PUB's Approval to Commence Works Requiring Earth Control Measures
- NParks' no-objection for specific sites with environmental mitigation and monitoring plan (EMMP) / wildlife management, prior to site clearance

**Commencement of Works**

- BCA's Permit to Commence Piling & relevant Substructure Works
- LTA's Rail Engineering Works Permit / Restricted Activity Approval
- PUB's Approval for Works Within Public Sewer / Water Pipe Corridor

**G1.5 Piling Gateway**

Legend:  Architecture  C&S  M&E IFC COMPONENT

Impact Studies only	
Agency	Requirement Category
NParks	<ul style="list-style-type: none"> <li><input checked="" type="checkbox"/> <b>Applicable to sites requiring Environmental Monitoring and Management Plan (EMMP) / Wildlife Management Plan prior to commencement of works:</b></li> <li>a) Detailed EMMP report (provided by Main Contractor)</li> <li>b) Acceptance letter from NParks prior to site clearance (if applicable)</li> </ul>

Impact Studies, Site Layout, Rail Protection	
Agency	Requirement Category
LTA	<p><b><u>Engineering Assessment for Piling Works within Railway Protection Zone / Railway Corridor</u></b></p> <ul style="list-style-type: none"> <li>• To submit plan for engineering works</li> <li>• To submit the Engineering evaluation report</li> <li>• To submit the Certified Survey Plans</li> <li>• To submit the Construction schedule for the proposed development</li> </ul> <p>Note: Refer to LTA's Code of Practice for Railway Protection / Guidebook for Carrying Out Modification Work to Rapid Transit System (RTS) Stations or Railway by Private Developer / Guide to carrying out restricted activities within railway protection and safety zones for more requirements / detailed description</p>

Lightning Protection	
Agency	Requirement Category
BCA	<p><b><u>Note: These requirements are currently optional and will only be required for regulatory compliance when LPS plan submission is mandated</u></b></p> <ul style="list-style-type: none"> <li>• For big projects adopting piles or raft foundation as natural earth-termination system. Provision of rebars for connection to the down-conductor system shall be provided during the piling stage.</li> </ul> <p><u>Notes:</u></p> <ul style="list-style-type: none"> <li>• QP (Electrical) to provide inputs for submission by C&amp;S</li> <li>• Developer or Builder is required to appoint a QP (Electrical) to supervise the LPS works before LPS Plan submission is carried out at the Construction Gateway (G2).</li> </ul>

**G1.5 Piling Gateway**

Legend:  Architecture  C&S  M&E IFC COMPONENT

Structural Design	
Agency	Requirement Category
<p>BCA</p> <div style="display: flex; flex-direction: column; gap: 5px;"> <div style="border: 1px solid #ccc; border-radius: 10px; padding: 2px 10px; text-align: center; font-size: 8px;">BEAM</div> <div style="border: 1px solid #ccc; border-radius: 10px; padding: 2px 10px; text-align: center; font-size: 8px;">BOREHOLE</div> <div style="border: 1px solid #ccc; border-radius: 10px; padding: 2px 10px; text-align: center; font-size: 8px;">FOOTING / PILECAP</div> <div style="border: 1px solid #ccc; border-radius: 10px; padding: 2px 10px; text-align: center; font-size: 8px;">PILE</div> <div style="border: 1px solid #ccc; border-radius: 10px; padding: 2px 10px; text-align: center; font-size: 8px;">SLAB</div> </div>	<p><b>Structural Design (Piling and Foundation Works)</b></p> <p><i>Can be provided at Piling Gateway (G1.5) or Construction Gateway (G2)</i></p> <ul style="list-style-type: none"> <li>• <b>Piling &amp; Foundation Works IFC-SG model</b></li> <li>• <b>Ground Investigation:</b> <ul style="list-style-type: none"> <li>○ Compliance with minimum number of borehole required as stipulated in Circular APPBCA-2016-08</li> </ul> </li> <li>• <b>2D Drawings limited to:</b> <ul style="list-style-type: none"> <li>○ General notes</li> <li>○ Irregular Pilecap / Footing Details</li> </ul> </li> </ul> <div style="margin-top: 10px;"> <div style="display: flex; align-items: flex-start;"> <div style="border: 1px solid #ccc; padding: 2px; margin-right: 5px;">             ✓ — — — — —           </div> <div> <p><b>Design Calculation reports:</b></p> <ul style="list-style-type: none"> <li>• From QP, AC, [QP(Geo) &amp; AC (Geo), if needed]</li> </ul> </div> </div> <div style="margin-top: 10px;"> <div style="display: flex; align-items: flex-start;"> <div style="border: 1px solid #ccc; padding: 2px; margin-right: 5px;">             ✓ — — — — —           </div> <div> <p><b>Additional Supporting Documents:</b></p> <ol style="list-style-type: none"> <li>a) Site investigation report in PDF &amp; AGS format</li> <li>b) Impact assessment report</li> <li>c) Topography</li> <li>d) Complete set of structural framing plan for reference</li> <li>e) Complete set of building plan for reference</li> <li>f) Completion letter of pre-consultation (for complex structure only)</li> </ol> </div> </div> </div> </div>

----- End of Requirements for Piling Gateway (G1.5) -----



## Construction Gateway

Agency	Summary of Construction Gateway Requirements	Common Gateway Key Words
<b>BCA</b>	<p><b><u>Detailed layout and design of development, consisting of:</u></b></p> <ul style="list-style-type: none"> <li>Structural design for superstructure with design calculations</li> <li>Accredited checker design calculations (if applicable)</li> <li>Building design with provision and design of:                             <ul style="list-style-type: none"> <li>Headroom and ceiling height</li> <li>Accessible route and facilities</li> <li>Staircases and barriers for safety</li> <li>Household / Storey shelter</li> <li>Materials (e.g. use of glass at height, daylight reflectance)</li> <li>Natural lighting</li> <li>Ventilation scheme</li> <li>Location of fixed installation (e.g. lift, escalator)</li> <li>Lightning protection system</li> <li>Energy efficiency, environmental sustainability and buildable design calculations</li> </ul> </li> </ul>	<ul style="list-style-type: none"> <li>Access to Site</li> <li>Access within Building</li> <li>Barrier</li> <li>Buildability</li> <li>Connectivity</li> <li>Dwelling Unit</li> <li>Equipment</li> <li>Environmental Sustainability</li> <li>Household / Storey Shelter</li> <li>Lifts &amp; Escalators</li> <li>Lightning Protection</li> <li>Materials</li> <li>Public / Transit Shelter</li> <li>Staircase</li> <li>Statistical Gross Floor Area</li> <li>Structural</li> <li>Vehicular Parking</li> <li>Ventilation</li> <li>Washroom</li> </ul>
<b>LTA</b>	<p><b><u>Detailed street plan showing:</u></b></p> <ul style="list-style-type: none"> <li>Proposed street works</li> <li>Details of access points</li> <li>Street lightings</li> <li>Signposts</li> <li>Other street related facilities (if any)</li> </ul> <p><b><u>For proposed new street and commuter facilities, to provide the following:</u></b></p> <ul style="list-style-type: none"> <li>Structural details of commuter facilities, retaining structures, flyovers</li> <li>M&amp;E provision and design</li> <li>Traffic layout plan</li> </ul> <p><b><u>Railway protection details for the review of overall impact to development with respect to RTS</u></b></p> <ul style="list-style-type: none"> <li>Plan for building works</li> <li>Engineering evaluation report etc</li> </ul>	<ul style="list-style-type: none"> <li>Impact Studies</li> <li>Infra &amp; Utilities (External)</li> <li>Rail Protection</li> <li>Site Layout</li> <li>Street Works</li> <li>Vehicular Parking</li> </ul>
<b>NEA</b>	<p>Building plans of the development and related building services to be developed in greater detail to comply with requirements for Pollution control and environmental health These include further development of the Design Gateway (G1) elements, as well as:</p> <ul style="list-style-type: none"> <li>Refuse Storage and Collection</li> <li>Sanitary facilities change to Public Toilet</li> <li>Ventilation, Ducting and Kitchen Exhaust Systems for Food Shop</li> <li>Cooling Tower</li> <li>Aquatic Facility</li> <li>Storage and Collection System for Recyclables at Strata-Titled properties with Residential Units</li> <li>Anti-Mosquito Breeding</li> <li>Technical Guidelines for Air Conditioning and Mechanical Ventilation system</li> <li>SS593: COPPC</li> <li>SS649: COPWCS</li> </ul>	<ul style="list-style-type: none"> <li>Dwelling Unit</li> <li>Equipment</li> <li>Pollution Control</li> <li>Public Health</li> </ul>

See also:

[Latest CORENET X Circulars](#)



## Construction Gateway

Agency	Summary of Construction Gateway Requirements <i>(continued from previous page)</i>	Common Gateway Key Words
<b>NParks</b>	<ul style="list-style-type: none"> <li>Interfacing Aspects (from within Development Boundary)</li> <li>Dimensions of planting areas and green verges compliant with standard requirements</li> <li>Review of allowable structures within planting areas and possibly alternative configuration of planting areas</li> <li>Detailed design of facilities and furniture for new Park/Park Connector/Promenade</li> <li>Planting requirements/specifications for covered linkways/pedestrian overhead bridges</li> </ul>	<ul style="list-style-type: none"> <li>Greenery</li> <li>Site Layout</li> </ul>
<b>PUB</b>	<p><b><u>Detailed plans of proposed drainage / sewerage / sanitary works including:</u></b></p> <ul style="list-style-type: none"> <li>Works affecting sanitary (e.g. sanitary drainage and plumbing work including last IC connection to public sewer)</li> <li>Works affecting Sanitary M&amp;E (used water pumping system, sewerage ejector)</li> <li>Works affecting Sewer (e.g. proposed sewer/manhole, pump sumps/pumping main, abandon sewers/manhole)</li> <li>RC Trench for housing the public sewer</li> <li>Works affecting Drainage (e.g. common drain, basement pump drainage system, detention tank, entrance culvert/roadside drain, flood protection measures, slab over drain for meter compartment)</li> </ul>	<ul style="list-style-type: none"> <li>ABC Waters</li> <li>Earthworks</li> <li>Infra &amp; Utilities (Internal)</li> </ul>
<b>SCDF</b>	<p><b><u>Building Plan (BP)</u></b></p> <p>Detailed layout and floor plan of the development and building showing:</p> <ul style="list-style-type: none"> <li>Fire safety provisions</li> <li>Means of escape</li> <li>Structural precautions</li> <li>Building's setback distances (with detailed calculations)</li> <li>Fire engine accessibility</li> <li>Rising mains &amp; hydrants</li> <li>Type of fire protection systems for every storey/spaces</li> <li>Mode of ventilation for spaces required ventilation</li> <li>Type of smoke control systems for spaces required such system</li> <li>Emergency voice communication system for every storey/spaces</li> </ul>	<ul style="list-style-type: none"> <li>Access within Building</li> <li>Equipment</li> <li>Fire Compartmentation</li> <li>Fire Fighting</li> <li>Household / Storey Shelter</li> <li>Lifts &amp; Escalators</li> <li>Materials</li> <li>Performance-Based project</li> <li>Staircase</li> <li>Ventilation</li> </ul>
<b>URA</b>	<p><b><u>Detailed layout and floor plan of development including:</u></b></p> <ul style="list-style-type: none"> <li>Strata boundaries (for strata-titled developments)</li> <li>Elevation details</li> <li>Exact floor area quantum of various uses and facilities</li> <li>GFA details e.g. proposed exemptions</li> </ul> <p>Depending on the location and special schemes that may apply to the site, the model will have to cater to details relevant to urban design and/or conservation requirements</p>	<ul style="list-style-type: none"> <li>Access to Site</li> <li>Access within Building</li> <li>Attic</li> <li>Balcony</li> <li>Basement</li> <li>Building / Unit Layout</li> <li>Building Massing</li> <li>Common Service Tunnel</li> <li>Connectivity</li> <li>Conservation</li> <li>Dwelling Unit</li> <li>Earthworks / Topography</li> <li>External Works</li> <li>Greenery</li> <li>Landscape Deck</li> <li>Night Lighting</li> <li>ORA / ODA / Kiosks</li> <li>Public Communications Plan</li> <li>Public Space</li> <li>Rapid Transit System (RTS) Station</li> <li>Roofscape</li> <li>Screening</li> <li>Signage</li> <li>Site Layout</li> <li>Structures in Building Setback</li> <li>Use &amp; Intensity</li> <li>Vehicular Parking</li> <li>Others</li> </ul>

See also:

[Latest CORNET X Circulars](#)

# Section 3: Specific Requirements by Key Gateways

## Construction Gateway

INTRODUCTION TO CX

GENERAL REQUIREMENTS

REGULATORY AGENCIES

**KEY GATEWAYS**

OTHER BUILDING WORKS

BIM DATA REPRESENTATION



# Construction Gateway

Legend: ■ Architecture ■ C&S ■ M&E IFC COMPONENT

ABC Waters	
Agency	Requirement Category
PUB	<p><b>ABC Waters Design Features</b></p> <p>For systems that include ABC Waters design features for peak runoff management, the detailed design, including detention volume to be provided, as endorsed by the ABC Waters Professional (who is also a PE(Civil)) shall be submitted</p>

Access to Site	
Agency	Requirement Category
<p>BCA</p> <p>ACCESSIBLE ROUTE SLAB</p> <p>RAMP STAIRCASE</p>	<ul style="list-style-type: none"> <li>Passenger Alighting and Boarding Point</li> <li>Accessible Route (to the development entrance)</li> </ul>
<p>URA</p> <p>ROAD SPACE</p>	<p><b>Site Layout</b></p> <ul style="list-style-type: none"> <li>Detailed location of Pedestrian, Cycling, Vehicular and Service Access</li> </ul>

Access within Building only	
Agency	Requirement Category
<p>BCA</p> <p>ACCESSIBLE ROUTE SLAB</p> <p>RAMP STAIRCASE</p>	<ul style="list-style-type: none"> <li>All Accessible Routes and associated clear Spaces (within the development)</li> <li>Accessible and elder-friendly rooms where relevant</li> <li>Seating and eating spaces for wheelchair users</li> <li>Resting areas for the ambulant disabled</li> <li>Location of hearing enhancement systems</li> </ul>
<p>URA</p> <p>SPACE</p>	<ul style="list-style-type: none"> <li>Corridor Width</li> </ul>

Attic	
Agency	Requirement Category
<p>URA</p> <p>SPACE</p>	<ul style="list-style-type: none"> <li>Design of attic</li> <li>Location of attic in relation to strata unit</li> </ul>

Balcony	
Agency	Requirement Category
<p>URA</p> <p>SPACE</p>	<p><b>Balconies, Private Enclosed Spaces, Private Roof Terraces and Indoor Recreation Spaces</b></p> <ul style="list-style-type: none"> <li>Balcony screening design illustrating openness and porosity for natural ventilation</li> </ul> <p> <b>Bonus Balcony GFA</b></p> <ul style="list-style-type: none"> <li>Letter of Declaration from Developer on Balcony Screen Design and Provision</li> </ul>

# G2 Construction Gateway

Legend:  Architecture  C&S  M&E IFC COMPONENT

Barrier	
Agency	Requirement Category
<div style="display: flex; align-items: center;"> <div style="width: 15px; height: 15px; background-color: orange; margin-right: 5px;"></div> <div style="width: 15px; height: 15px; background-color: green; margin-right: 5px; margin-left: 5px;"></div> <div style="margin-left: 10px;"> <p>BCA</p> <div style="border: 1px solid gray; border-radius: 10px; padding: 2px 5px; margin-top: 5px;">RAILING</div> </div> </div>	<ul style="list-style-type: none"> <li>Safety from falling (ie. safety barrier height, size of any openings, kerb)</li> <li>Protection from injury by vehicles in building (e.g. provision of bollards)</li> </ul>

Buildability	
Agency	Requirement Category
<div style="display: flex; align-items: center;"> <div style="width: 15px; height: 15px; background-color: orange; margin-right: 5px;"></div> <div style="width: 15px; height: 15px; background-color: green; margin-right: 5px; margin-left: 5px;"></div> <div style="width: 15px; height: 15px; background-color: yellow; margin-right: 5px; margin-left: 5px;"></div> <div style="margin-left: 10px;"> <p>BCA</p> </div> </div>	<p><b><u>Buildability Design Implementation Plan (BDIP)</u></b></p> <ul style="list-style-type: none"> <li>BIM model which describes and defines the type, extent of use and details of the Design for Manufacturing (DfMA) technologies, building systems, building components, buildable features, design standardisation across the Structural, Architectural and Mechanical, Electrical and Plumbing (MEP) systems</li> <li>Where any of the above cannot be modelled in BIM, 2D plans can be submitted</li> </ul> <p> <b><u>Buildable Design Score (B-Score)</u></b></p> <p>a) BS01 Form (in Excel format) to be submitted</p>

Building / Unit Layout	
Agency	Requirement Category
<div style="display: flex; align-items: center;"> <div style="width: 15px; height: 15px; background-color: orange; margin-right: 5px;"></div> <div style="margin-left: 10px;"> <p>URA</p> <div style="border: 1px solid gray; border-radius: 10px; padding: 2px 5px; margin-top: 5px;">BUILDING STOREY</div> </div> </div>	<p><b><u>Unit / Floor Layout (All)</u></b></p> <ul style="list-style-type: none"> <li>Floor layout and unit size</li> <li>Strata areas and boundaries / voids</li> </ul> <p><b><u>Dwelling Units (Residential)</u></b></p> <ul style="list-style-type: none"> <li>Breakdown of units by type / size</li> <li>Unit layouts with breakdown of respective internal areas including balconies and air-con ledges</li> </ul>

Building Facade	
Agency	Requirement Category
<div style="display: flex; align-items: center;"> <div style="width: 15px; height: 15px; background-color: orange; margin-right: 5px;"></div> <div style="margin-left: 10px;"> <p>URA</p> </div> </div>	<p> <b><u>Design Treatment for Building Facade</u></b></p> <ul style="list-style-type: none"> <li>Illustrate design using perspectives</li> <li>Screening details of M&amp;E equipment / multi-storey carpark, where required</li> </ul>

# G2 Construction Gateway

Legend:  Architecture  C&S  M&E IFC COMPONENT

Building Envelope	
Agency	Requirement Category
BCA	<p><b>ETTV</b></p> <ul style="list-style-type: none"> <li>ETTV computation &amp; tabulation of design parameters in the prescribed forms &amp; formats;</li> <li>Architectural elevation drawings showing the composition of the different façade or wall systems that are relevant for the computation of the ETTV; and</li> <li>Architectural plan layouts &amp; elevations showing the mode of ventilation &amp; location for various spaces incl. air-conditioning areas.</li> </ul> <p><b>RTTV</b></p> <ul style="list-style-type: none"> <li>RTTV computation for roofs with skylight in prescribed forms and formats, where relevant;</li> <li>Architectural plan layout and sectional details of different roof types as well as the roof composition and respective U-values; and</li> <li>Technical material or product information and relevant calculation of U-value of the roof</li> </ul> <p><i>ETTV / RETV Calculation Format in respect of an Air-conditioned Building (BPD_BP04):</i>  <a href="https://www1.bca.gov.sg/docs/default-source/docs-corp-form/bp04.doc?sfvrsn=c3a0dcf4_2">https://www1.bca.gov.sg/docs/default-source/docs-corp-form/bp04.doc?sfvrsn=c3a0dcf4_2</a></p>

Common Services Tunnel	
Agency	Requirement Category
URA	<ul style="list-style-type: none"> <li>Detailed Work sequence of CST vent shaft/entrance integration</li> <li>Link chamber services connection layout and structural details including supporting structures</li> <li>Ventilation shaft/entrance details including louvres/screening details and supporting structures</li> <li>Waterproofing details</li> </ul>

Connectivity	
Agency	Requirement Category
URA  <div style="display: flex; flex-direction: column; gap: 5px;"> <div style="border: 1px solid gray; border-radius: 10px; padding: 2px 5px; text-align: center; font-size: 8px;">DISTRIBUTION CHAMBER</div> <div style="border: 1px solid gray; border-radius: 10px; padding: 2px 5px; text-align: center; font-size: 8px;">WATER METER</div> <div style="border: 1px solid gray; border-radius: 10px; padding: 2px 5px; text-align: center; font-size: 8px;">PARKING LOT</div> <div style="border: 1px solid gray; border-radius: 10px; padding: 2px 5px; text-align: center; font-size: 8px;">SPACE</div> <div style="border: 1px solid gray; border-radius: 10px; padding: 2px 5px; text-align: center; font-size: 8px;">FOOTPATH</div> </div>	<p><b>Pedestrian Network</b></p> <p>Through Block Link (TBL), Underground Pedestrian Link(UPL), Elevated Pedestrian Link (EPL), Covered Walkways (CW), Open Walkways (OW), Covered Linkways (CL), High Covered Linkways (HCL)</p> <ul style="list-style-type: none"> <li>Loading provision to receive future walkways / linkways (if any)</li> <li>Notional scheme for future link to justify the loading (recipient)</li> </ul> <p>Additional requirements for the following:</p> <ul style="list-style-type: none"> <li>(CW) Soffit height, overall width and clear width</li> <li>(OW/CW) Paving material (where required in UD guidelines)</li> <li>(OW/CW) Level of bulk water meter chamber / inspection chamber</li> <li>(TBL) Location and Size of Signage</li> <li>(HCL) Flashing to prevent wind driven rain</li> </ul> <p><b>Walking and Cycling Plan</b></p> <ul style="list-style-type: none"> <li>Connectivity between buildings – show layout on plans, indicate width and levels</li> <li>Segregation between vehicular and pedestrian / cyclist traffic</li> <li>Provision of biking lots and end-of-trip facilities – show location and GFA exemption</li> </ul>

Conservation	
Agency	Requirement Category
URA	<a href="#">Refer to URA Conservation Requirements here</a>





# Construction Gateway

Legend: ■ Architecture ■ C&S ■ M&E IFC COMPONENT

Dwelling Units		
	Agency	Requirement Category
	BCA	<ul style="list-style-type: none"> <li>Bathrooms for future retrofitting</li> <li>Design of unit entrance for wheelchair users</li> </ul>

Earthworks / Topography		
	Agency	Requirement Category
	PUB	<ul style="list-style-type: none"> <li>Slope calculation report</li> </ul>
	URA	<p><b>Earthworks, Retaining Walls, and Boundary Walls</b></p> <ul style="list-style-type: none"> <li>Proposed site and platform levels</li> <li>Earthworks</li> <li>Boundary wall</li> <li>Retaining wall</li> </ul>
	<div style="border: 1px solid gray; border-radius: 15px; padding: 2px 5px; display: inline-block;">WALL</div>  <div style="border: 1px solid gray; border-radius: 15px; padding: 2px 5px; display: inline-block;">EARTHWORKS</div>	

Emergency Voice Communication System		
	Agency	Requirement Category
	SCDF	<p><b>Emergency Voice Communication System and Fire Command Centre</b></p> <ul style="list-style-type: none"> <li>Declaration of one-way / two-way emergency voice communication system for the functional space</li> </ul>

Environmental Sustainability		
	Agency	Requirement Category
	BCA	<p><b>For Code for Environmental Sustainability of Buildings:</b></p> <p><u>To submit the following:</u></p> <ol style="list-style-type: none"> <li>i. BC ES Appendix 1 for <b>Construction Gateway</b> <a href="https://go.gov.sg/bc-es-app1">https://go.gov.sg/bc-es-app1</a></li> <li>ii. Documentary Evidence on Maintenance of Building Cooling System Performance (NRB06)</li> <li>iii. ACMV plan drawing showing the requirement.</li> </ol> <p>Guidance Notes and Documentation Requirements under Code for Environmental Sustainability of Buildings: <a href="https://www1.bca.gov.sg/buildsg/sustainability/regulatory-requirements-for-new-buildings-existing-buildings-undergoing-major-aanda">https://www1.bca.gov.sg/buildsg/sustainability/regulatory-requirements-for-new-buildings-existing-buildings-undergoing-major-aanda</a></p>
		<p><b>For Government Land Sales (GLS) programme requirement:</b></p> <p>please refer to the following link: <a href="https://www1.bca.gov.sg/buildsg/sustainability/regulatory-requirements-for-new-buildings-existing-buildings-undergoing-major-aanda/mandatory-higher-green-mark-standard">https://www1.bca.gov.sg/buildsg/sustainability/regulatory-requirements-for-new-buildings-existing-buildings-undergoing-major-aanda/mandatory-higher-green-mark-standard</a></p>



# Construction Gateway

Legend:  Architecture  C&S  M&E IFC COMPONENT

Environmental Health	
Agency	Requirement Category
<p>NEA</p> <p>INTERCEPTOR</p> <p>PUMP</p> <p>SANITARY APPLIANCES</p> <p>GUTTER</p> <p>TANK</p> <p>SYSTEM</p> <p>SPACE</p> <p>REFUSE HANDLING EQUIPMENT</p> <p>SENSOR</p> <p>SHADING DEVICE</p> <p>CONTROL ELEMENT</p> <p>REFUSE CHUTE / RECYCLABLES CHUTE</p> <p>DISTRIBUTION CHAMBER</p>	<p><b><u>COPEH - Section 1 : Refuse Storage and Collection</u></b></p> <p>The spatial provision set aside for Pneumatic waste conveyance system (PWCS) cleared at Design Gateway (G1) must continue to be provided at CG. Applicants are required to furnish details regarding their proposals, building upon the spatial provisions previously submitted at DG.</p> <p>1.1 Objective                      1.2 Refuse Output                      1.3 Refuse Chute                      1.4 Refuse Chute Chamber                      1.5 Refuse Room</p> <p>1.6 Refuse Bin Point and Refuse Bin Centre                      1.7 Pneumatic Waste Conveyance System (PWCS)                      1.8 Mandatory Waste Reporting Scheme                      1.9 Location of Grease Trap                      1.10 On-Site Food Waste Treatment System</p> <p>Note: NEA is currently reviewing the submission requirements for PWCS.</p> <p><b>When to apply:</b></p> <ul style="list-style-type: none"> <li>Applicants should provide the above information (either in 2D, 3D or supporting documents) and should be concluded by Construction Gateway (G2).</li> </ul> <p><b>Who to submit:</b></p> <ul style="list-style-type: none"> <li>QP appointed should submit the above information and keep other relevant QPs in the loop.</li> <li>The same QP should follow through the submissions for all gateways.</li> </ul>
	<p><b><u>COPEH - Section 2 : Public Toilet</u></b></p> <p>2.1 Objective                      2.2 Definition of Public Toilet                      2.3 General Design Criteria</p> <p>2.4 Sanitary and Water Fittings Required in Public Toilet                      2.5 Amenities to be Provided                      2.6 Ventilation</p> <p><b>When to apply:</b></p> <ul style="list-style-type: none"> <li>Applicants should provide the above information (either in 2D, 3D or supporting documents) and should be concluded by Construction Gateway (G2).</li> </ul> <p><b>Who to submit:</b></p> <ul style="list-style-type: none"> <li>QP appointed should submit the above information and keep other relevant QPs in the loop.</li> <li>The same QP should follow through the submissions for all gateways.</li> </ul>
	<p><b><u>COPEH - Section 3 : Ventilation, Ducting and Kitchen Exhaust Systems for Food Shop</u></b></p> <p>3.1 Objective                      3.2 Design Requirements</p> <p>3.3 Operations Requirements                      3.4 Other Requirements and Guidelines</p> <p><b>When to apply:</b></p> <ul style="list-style-type: none"> <li>Applicants should provide the above information (either in 2D, 3D or supporting documents) and should be concluded by Construction Gateway (G2). <b>Terminals and façade louvres are to be modelled. Ducting can be in 2D or 3D.</b></li> </ul> <p><b>Who to submit:</b></p> <ul style="list-style-type: none"> <li>QP appointed should submit the above information and keep other relevant QPs in the loop.</li> <li>The same QP should follow through the submissions for all gateways.</li> </ul>



# Construction Gateway

Legend:  Architecture  C&S  M&E IFC COMPONENT

Environmental Health <i>(continued from previous page)</i>	
Agency	Requirement Category
<p>NEA</p> <p><i>(continued from previous page)</i></p>	<p><b><u>COPEH - Section 4 : Cooling Tower <i>(when it is provided)</i></u></b></p> <p>4.1 Objective 4.2 Design Requirements</p> <p><b>When to apply:</b></p> <ul style="list-style-type: none"> <li>Applicants should provide the above information (either in 2D, 3D or supporting documents) and should be concluded by Construction Gateway (G2)</li> </ul> <p><b>Who to submit:</b></p> <ul style="list-style-type: none"> <li>QP appointed should submit the above information and keep other relevant QPs in the loop.</li> <li>The same QP should follow through the submissions for all gateways.</li> </ul>
	<p><b><u>COPEH - Section 5 : Aquatic Facility</u></b></p> <p>5.1 Objective 5.2 Minimum Design Criteria</p> <p><b>When to apply:</b></p> <ul style="list-style-type: none"> <li>Applicants should provide the above information (either in 2D, 3D or supporting documents) and should be concluded by Construction Gateway (G2). <a href="#">Balancing Tank is to be modelled.</a></li> </ul> <p><b>Who to submit:</b></p> <ul style="list-style-type: none"> <li>QP appointed should submit the above information and keep other relevant QPs in the loop.</li> <li>The same QP should follow through the submissions for all gateways.</li> </ul>
	<p><b><u>COPEH - Section 6 : Storage and Collection System for Recyclables at Strata-Titled properties with Residential Units</u></b></p> <p>6.1 Objective 6.2 Recyclables Output</p> <p><b>When to apply:</b></p> <ul style="list-style-type: none"> <li>Applicants should provide the above information (either in 2D, 3D or supporting documents) and should be concluded by Construction Gateway (G2).</li> </ul> <p><b>Who to submit:</b></p> <ul style="list-style-type: none"> <li>QP appointed should submit the above information and keep other relevant QPs in the loop.</li> <li>The same QP should follow through the submissions for all gateways.</li> </ul>
	<p><b><u>COPEH - Section 7 : Anti-Mosquito Breeding</u></b></p> <p>7.1 Objective 7.2 Roof Gutter</p> <p><b>When to apply:</b></p> <ul style="list-style-type: none"> <li>Applicants should provide the above information (either in 2D, 3D or supporting documents) and should be concluded by Construction Gateway (G2)</li> </ul> <p><b>Who to submit:</b></p> <ul style="list-style-type: none"> <li>QP appointed should submit the above information and keep other relevant QPs in the loop.</li> <li>The same QP should follow through the submissions for all gateways.</li> </ul>

# G2 Construction Gateway

Legend:  Architecture  C&S  M&E IFC COMPONENT

Exit	
Agency	Requirement Category
SCDF <div style="border: 1px solid gray; border-radius: 10px; padding: 2px; width: fit-content; margin-bottom: 5px;">STAIRCASE</div> <div style="border: 1px solid gray; border-radius: 10px; padding: 2px; width: fit-content;">SPACE</div>	<b>Means of Escape</b> <ul style="list-style-type: none"> <li>• Compliance of adequate means of escape:                             <ul style="list-style-type: none"> <li>○ Adequate provision of exit staircase, exit door &amp; exit access door</li> <li>○ Capacity of exits and occupant load calculation</li> <li>○ Requirements of Internal &amp; external exit staircase</li> <li>○ Remoteness of exit</li> <li>○ Travel distance</li> <li>○ Smoke-free approach to exit staircase</li> <li>○ Discharge of exit staircase</li> <li>○ Ventilation of exits</li> <li>○ Staircase re-entry</li> </ul> </li> <li>• Compliance of special requirements for Person With Disabilities (PWDs) are provided:                             <ul style="list-style-type: none"> <li>○ Provision of PWD holding point unless otherwise exempted</li> <li>○ Siting of PWD holding point</li> <li>○ Protection of PWD holding point</li> </ul> </li> </ul>

Exit Sign and Emergency Lighting	
Agency	Requirement Category
SCDF <div style="border: 1px solid gray; border-radius: 10px; padding: 2px; width: fit-content; margin-bottom: 5px;">SECURITY LIGHTING</div> <div style="border: 1px solid gray; border-radius: 10px; padding: 2px; width: fit-content;">SIGNAGE</div>	<b>Exit Sign (incl. low level signs), Emergency Lighting, Photoluminescent Lighting</b> <ul style="list-style-type: none"> <li>• Types of buildings / areas, and locations require exit sign, photoluminescent lighting &amp; emergency lighting</li> </ul>

External Works	
Agency	Requirement Category
URA <div style="border: 1px solid gray; border-radius: 10px; padding: 2px; width: fit-content; margin-bottom: 5px;">FOOTPATH</div>	<ul style="list-style-type: none"> <li>• Design treatment for public street lighting, bollards, tactile tiles (UD requirement for CBD / Marina Bay)</li> <li>• Promenade Guidelines (UD requirements for Singapore River)</li> <li>• Paving Guideline for Orchard, Downtown Core and the Civic District (OW) Paving material</li> </ul>

Fire Alarm System	
Agency	Requirement Category
SCDF <div style="border: 1px solid gray; border-radius: 10px; padding: 2px; width: fit-content; margin-bottom: 5px;">FIRE ALARM</div> <div style="border: 1px solid gray; border-radius: 10px; padding: 2px; width: fit-content; margin-bottom: 5px;">WATER TANK</div> <div style="border: 1px solid gray; border-radius: 10px; padding: 2px; width: fit-content; margin-bottom: 5px;">VALVE</div> <div style="border: 1px solid gray; border-radius: 10px; padding: 2px; width: fit-content; margin-bottom: 5px;">BREECHING INLET</div> <div style="border: 1px solid gray; border-radius: 10px; padding: 2px; width: fit-content; margin-bottom: 5px;">SYSTEM</div> <div style="border: 1px solid gray; border-radius: 10px; padding: 2px; width: fit-content; margin-bottom: 5px;">SPRINKLER</div> <div style="border: 1px solid gray; border-radius: 10px; padding: 2px; width: fit-content;">SPACE</div>	<b>Automatic Fire Alarm (Heat / Smoke Detector)</b> <ul style="list-style-type: none"> <li>• Types of buildings / usage require provision of automatic fire alarm</li> <li>• Type of buildings/ usage exempt from provision of automatic fire alarm</li> <li>• QP to declare automatic fire alarm system is provided for the functional space</li> </ul> <p><u>Components to be indicated:</u></p> <ul style="list-style-type: none"> <li>○ Fire Alarm Panel</li> </ul>



# Construction Gateway



Legend:  Architecture  C&S  M&E IFC COMPONENT

Fire Alarm System <i>(continued from previous page)</i>	
Agency	Requirement Category
SCDF  <i>(continued from previous page)</i>	<p><b><u>Combined Sprinkler and Wet Riser System</u></b></p> <ul style="list-style-type: none"> <li>Types of buildings / areas allow combined sprinkler and wet riser system</li> <li>QP to declare combined sprinkler and wet riser system is provided for the functional space</li> </ul> <p><u>Components to be modelled:</u></p> <ul style="list-style-type: none"> <li>Location of Sprinkler Control Valve</li> <li>Breeching Inlet (2-way or 4-way)</li> <li>Landing Valve</li> <li>Fire alarm panel</li> </ul>
	<p><b><u>Home Fire Alarm Device (HFAD)</u></b></p> <ul style="list-style-type: none"> <li>Types of building require HFAD</li> <li>QP to declare Home Fire Alarm Device is provided for the functional space</li> <li>Compliance of location and number of HFAD points</li> </ul>
	<p><b><u>Manual Alarm System</u></b></p> <ul style="list-style-type: none"> <li>Types of building / usage require manual call points</li> <li>QP to declare manual alarm system is provided for the functional space</li> </ul> <p><u>Components to be modelled:</u></p> <ul style="list-style-type: none"> <li>Manual alarm call points</li> <li>Fire alarm sounder</li> <li>Visual alarm device</li> <li>Fire alarm panel</li> </ul>
	<p><b><u>Sprinkler System</u></b></p> <ul style="list-style-type: none"> <li>Types of buildings / usage require sprinkler system</li> <li>Types of buildings / usage exempt from provision of sprinkler system</li> <li>Provision of sprinklers for basement and aboveground buildings</li> <li>QP to declare sprinkler system is provided for the functional space</li> </ul> <p><u>Components to be modelled:</u></p> <ul style="list-style-type: none"> <li>Location of sprinkler control valve</li> <li>Breeching inlet (2-way or 4-way)</li> <li>Fire alarm panel</li> </ul>
	<p><b><u>Video Image Fire Detection System (VIFDS)</u></b></p> <ul style="list-style-type: none"> <li>Types of buildings require VIFDS</li> <li>QP to declare video image fire detection system is provided for the functional space</li> </ul>
	<p><b><u>Water Mist System</u></b></p> <ul style="list-style-type: none"> <li>Compliance of requirements for water mist system as a substitute of sprinkler system</li> <li>QP to declare water mist system is provided for the functional space</li> </ul>

**G2 Construction Gateway**

Legend:  Architecture  C&S  M&E IFC COMPONENT

Fire Lift	
Agency	Requirement Category
SCDF	<p><b><u>Fire Lift</u></b></p> <ul style="list-style-type: none"> <li>• Compliance of buildings (other than PG I &amp; II) provided with at least two fire lifts on every storey when habitable height exceeds 24m</li> <li>• Basement exceeding 9m shall be provided with at least 2 fire lifts (other than PG I)</li> <li>• Compliance of one fire lift for PG II buildings exceeding 24m.</li> <li>• Compliance of two fire lifts for PG II super hig-rise building exceeding 40 storeys.                             <ul style="list-style-type: none"> <li>○ Compliance of fire resistance rating for lift shaft</li> <li>○ Fire lift to serve continuous throughout the building, including basements</li> <li>○ Distance between fire lift landing door and exit staircase not exceeding 5m &amp; 10m (applicable to PG II discharge floor only)</li> <li>○ Fire lift to be accessible to any part of the storey</li> <li>○ 60m coverage for fire lift (except PG I &amp; II)</li> </ul> </li> </ul>

Firefighting System	
Agency	Requirement Category
<p>SCDF</p> <div style="display: flex; flex-direction: column; gap: 5px;"> <div style="border: 1px solid gray; border-radius: 10px; padding: 2px 10px; text-align: center; font-size: 8px;">LIFT</div> <div style="border: 1px solid gray; border-radius: 10px; padding: 2px 10px; text-align: center; font-size: 8px;">HOSEREEL</div> <div style="border: 1px solid gray; border-radius: 10px; padding: 2px 10px; text-align: center; font-size: 8px;">VALVE</div> <div style="border: 1px solid gray; border-radius: 10px; padding: 2px 10px; text-align: center; font-size: 8px;">SYSTEM</div> <div style="border: 1px solid gray; border-radius: 10px; padding: 2px 10px; text-align: center; font-size: 8px;">SPACE</div> <div style="border: 1px solid gray; border-radius: 10px; padding: 2px 10px; text-align: center; font-size: 8px;">FIRE HYDRANT</div> <div style="border: 1px solid gray; border-radius: 10px; padding: 2px 10px; text-align: center; font-size: 8px;">BREECHING INLET</div> <div style="border: 1px solid gray; border-radius: 10px; padding: 2px 10px; text-align: center; font-size: 8px;">FIRE EXTINGUISHER</div> </div>	<p><b><u>Evacuation Lift</u></b></p> <ul style="list-style-type: none"> <li>• Evacuation lift for evacuation of occupants to be modelled for building with habitable height exceeding 24m (except PG 1 &amp; 2):                             <ul style="list-style-type: none"> <li>○ Can double-up as PWD evacuation lift</li> <li>○ One of fire lifts can be used as evacuation lift</li> <li>○ Provision of means of communications &amp; CCTVs</li> <li>○ Provision of evacuation switch</li> </ul> </li> <li>• Evacuation lift for evacuation of PWD to be modelled for buildings more than 4 storey:                             <ul style="list-style-type: none"> <li>○ At least one evacuation lift required, passenger lift can be used as evacuation lift</li> <li>○ Provision of protected lobby</li> </ul> </li> </ul> <p><b><u>Fire Hydrant</u></b></p> <ul style="list-style-type: none"> <li>• Indication of private and public hydrant serving the project</li> <li>• Hydrant coverage not more than 50m from the fire engine accessway / access road</li> </ul> <p><b><u>Components to be modelled</u></b></p> <ul style="list-style-type: none"> <li>○ Full design of private/public hydrant, excluding underground piping.</li> </ul> <div style="display: flex; justify-content: space-around; margin-top: 10px;"> <div style="text-align: center;">  <p>Private hydrant</p> </div> <div style="text-align: center;">  <p>Public hydrant</p> </div> </div>

# Section 3: Specific Requirements by Key Gateways

## Construction Gateway

INTRODUCTION TO CX

GENERAL REQUIREMENTS

REGULATORY AGENCIES

**KEY GATEWAYS**

OTHER BUILDING WORKS

BIM DATA REPRESENTATION



# Construction Gateway

Legend: ■ Architecture ■ C&S ■ M&E IFC COMPONENT

Firefighting System (continued from previous page)	
Agency	Requirement Category
<p>SCDF</p> <p><i>(continued from previous page)</i></p> <p>LIFT</p> <p>HOSEREEL</p> <p>VALVE</p> <p>SYSTEM</p> <p>SPACE</p> <p>FIRE HYDRANT</p> <p>BREECHING INLET</p> <p>FIRE EXTINGUISHER</p>	<p><b><u>Hose Reel</u></b></p> <ul style="list-style-type: none"> <li>Compliance of provision of hose reel</li> <li>Number of hose reel</li> <li>Coverage of hose reel (30m+6m)</li> <li>Types of buildings / areas require provision of hose reel</li> <li>Types of buildings / areas exempt from provision of hose reel</li> <li>Siting of hose reel</li> </ul> <p><b><u>Components to be modelled</u></b></p> <ul style="list-style-type: none"> <li>Hose reel cabinet/enclosure.</li> <li>Hose reel drum with hose can be represented by object</li> <li>Need not model the piping for hose reel</li> </ul> <p><b><u>Portable Fire Extinguisher</u></b></p> <ul style="list-style-type: none"> <li>Types of buildings / areas require portable extinguisher</li> <li>Types of buildings / areas exempt from provision of portable extinguisher</li> <li>Siting of portable extinguisher</li> </ul> <p><b><u>Rising Mains and System</u></b></p> <ul style="list-style-type: none"> <li>Type of rising main provided (Dry or Wet)</li> <li>Number of rising main</li> <li>Siting and coverage of landing valve</li> </ul> <p><b><u>Components to be modelled for Dry and Wet Riser:</u></b></p> <ul style="list-style-type: none"> <li>Breeching inlet (to show 2-way or 4-way)</li> <li>Landing valve</li> <li>Wet riser tank (for wet riser only)</li> <li>Wet riser pump (for wet riser only)</li> </ul> <p><b><u>Provision of Standby Fire Hose:</u></b></p> <ul style="list-style-type: none"> <li>Types of buildings requiring standby fire hose</li> <li>Number of standby hose</li> <li>Located not more than 2m from landing valve</li> </ul> <p>Standby hose need not be modelled in full, the cabinet/enclosure for standby hose if provided shall be modelled in full.</p> <p><b><u>Provision of Breeching Inlet:</u></b></p> <ul style="list-style-type: none"> <li>Location</li> <li>Number</li> </ul>

Greenery	
Agency	Requirement Category
<p>NParks</p> <p>LANDSCAPE PLANTS</p>	<p><b><u>Conservation of Trees</u></b></p> <ul style="list-style-type: none"> <li>To conserve trees identified:             <ul style="list-style-type: none"> <li>In Technical Conditions of Tender (TCOT)</li> <li>As Heritage Trees</li> <li>Through public engagement</li> <li>In Environmental Impact Assessments (EIA) / Environmental Management and Monitoring Plans (EMMP) etc.</li> </ul> </li> </ul> <p> <b><u>Supporting Document(s):</u></b></p> <p>a) Arborist report (Please refer to NParks' Guidelines [Chapter 2])</p>

# G2 Construction Gateway

Legend: ■ Architecture ■ C&S ■ M&E IFC COMPONENT

## Greenery (continued from previous page)

	Agency	Requirement Category
	URA <div style="display: flex; justify-content: space-around; margin-top: 10px;"> <div style="border: 1px solid gray; border-radius: 10px; padding: 5px; width: 40%;">PLANTER BOX</div> <div style="border: 1px solid gray; border-radius: 10px; padding: 5px; width: 40%;">PLANTING AREA</div> </div> <div style="display: flex; justify-content: space-around; margin-top: 10px;"> <div style="border: 1px solid gray; border-radius: 10px; padding: 5px; width: 40%;">SPACE</div> <div style="border: 1px solid gray; border-radius: 10px; padding: 5px; width: 40%;">LANDSCAPE PLANTS</div> </div>	<ul style="list-style-type: none"> <li>Landscape Replacement Area – Provide Green Plot Ratio and total % of landscape replacement, with breakdown of hardscape and softscape</li> <li>Declare Location of Sky Terrace / Planter Boxes / Covered Communal Ground Garden / Communal Pavilions</li> </ul> <div style="margin-top: 10px;"> <b>Supplementary Documents</b> <ol style="list-style-type: none"> <li>Landscape plan / species and perspectives</li> <li>Plant details of sky terrace / planter boxes / covered communal ground garden / communal pavilions</li> </ol> </div>

## Headroom and Ceiling Height

	Agency	Requirement Category
	BCA	<ul style="list-style-type: none"> <li>Headroom of every room, access route and circulation areas</li> <li>Ceiling height of rooms and spaces</li> </ul>

## Household / Storey Shelter (HS/SS)

	Agency	Requirement Category	
	BCA	<p><b>Architecture</b></p> <p>Compliance with technical requirements on HS/SS position, area, volume, setback requirements, SS compartmentalization, HS/SS wall requirements, HS/SS door and SS blast hatch requirements, shielding wall requirements, HS/SS ventilation sleeve requirements, NS requirements, voids within HS/SS setback distance, downhang beam and trellis requirements, service risers &amp; gas risers &amp; refuse chute requirements, electrical power sockets outlets, telephony outlets and lighting points. Where any of the above cannot be modelled in BIM, 2D plans can be submitted</p>	<p><b>C&amp;S</b></p> <ul style="list-style-type: none"> <li>Compliance to structural requirements stipulated in technical requirements on household shelters and storey shelters. Where any of the above cannot be modelled in BIM, 2D plans can be submitted</li> </ul>
		<div style="margin-bottom: 5px;"> <b>Supporting Documents:</b> </div> <ol style="list-style-type: none"> <li>Submit HS/SS Shock Calculations as supplementary non-BIM documentation</li> </ol>	







# Construction Gateway

Legend:



Architecture



C&S



M&E

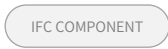

## Impact Studies only

Agency	Requirement Category
LTA	<p><b><u>Building Proposal within Railway Protection Zone/ Railway Corridor</u></b></p> <ul style="list-style-type: none"> <li>To submit plans for building works.</li> <li>To submit the Engineering Evaluation Report accompanied by plan for engineering works.</li> <li>To submit the Construction Schedule for the proposed development.</li> </ul> <p>Note: Refer to LTA's Code of Practice for Railway Protection / Guidebook for Carrying Out Modification Work to Rapid Transit System (RTS) Stations or Railway by Private Developer for more requirements/ detailed description</p>
NEA	<p><b><u>Energy Efficiency Opportunities Assessment (EEOA) for New Ventures</u></b></p> <p>EEOA will be required for new industrial facilities and major expansions of existing facilities with an estimated annual energy consumption (AEC) <math>\geq 54TJ</math> must review the facility design and develop economically feasible for energy efficiency opportunities</p> <ul style="list-style-type: none"> <li>Applicants are required to submit EEOA report to NEA directly via email to <a href="mailto:DCLD_consultation@nea.gov.sg">DCLD_consultation@nea.gov.sg</a></li> </ul>
NParks	<p><i>Applicable to sites not requiring Piling Gateway (G1.5) approval</i></p> <p><b>Applicable to sites requiring Environmental Monitoring and Management Plan (EMMP) / Wildlife Management Plan prior to commencement of works:</b></p> <ol style="list-style-type: none"> <li>Detailed EMMP report (provided by Main Contractor)</li> <li>Acceptance letter from NParks prior to site clearance (if applicable)</li> </ol>

## Impact Studies, Site Layout, Rail Protection

Agency	Requirement Category
LTA	<p><b><u>Approval to Commence Piling Works within Railway Protection Zone / Railway Corridor</u></b></p> <ul style="list-style-type: none"> <li>To submit plan for engineering works</li> <li>To submit the Engineering evaluation report</li> <li>To submit an Instrumentation Proposal and initial instrumentation readings</li> <li>To submit a Method Statement of work</li> <li>To submit a Hazard Analysis identifying all possible risks that may be posed to the rapid transit system and a description of the safety and precautionary measures to mitigate these risks</li> <li>To submit the Contingency Plan and Emergency Procedure</li> <li>To submit the Pre-condition Survey Report</li> <li>To submit the Certified Survey Plans</li> <li>To submit the Permit application form and other relevant forms</li> <li>To submit the Construction schedule for the proposed development</li> </ul> <p>Note: Refer to LTA's Code of Practice for Railway Protection / Guidebook for Carrying Out Modification Work to Rapid Transit System (RTS) Stations or Railway by Private Developer / Guide to carrying out restricted activities within railway protection and safety zones for more requirements / detailed description</p>

# Section 3: Specific Requirements by Key Gateways

## Construction Gateway

INTRODUCTION TO CX

GENERAL REQUIREMENTS

REGULATORY AGENCIES

**KEY GATEWAYS**

OTHER BUILDING WORKS

BIM DATA REPRESENTATION



# Construction Gateway

Legend: ■ Architecture ■ C&S ■ M&E IFC COMPONENT

Agency		Requirement Category
<b>PUB</b> <div style="display: flex; flex-wrap: wrap; gap: 10px;"> <div style="border: 1px solid gray; border-radius: 10px; padding: 5px; width: 100px; text-align: center;">INSPECTION CHAMBER</div> <div style="border: 1px solid gray; border-radius: 10px; padding: 5px; width: 100px; text-align: center;">PUMP</div> <div style="border: 1px solid gray; border-radius: 10px; padding: 5px; width: 100px; text-align: center;">INTERCEPTOR</div> <div style="border: 1px solid gray; border-radius: 10px; padding: 5px; width: 100px; text-align: center;">WASTE TERMINAL</div> <div style="border: 1px solid gray; border-radius: 10px; padding: 5px; width: 100px; text-align: center;">SYSTEM</div> <div style="border: 1px solid gray; border-radius: 10px; padding: 5px; width: 100px; text-align: center;">VALVE</div> <div style="border: 1px solid gray; border-radius: 10px; padding: 5px; width: 100px; text-align: center;">TANK (STORAGE)</div> </div>		<b><u>Sanitary Network</u></b> <ul style="list-style-type: none"> <li>• Drain-lines, Inspection Chamber, Discharge Lines, etc.</li> <li>• Sanitary Stack System</li> </ul>
		<b><u>Basement Pumped System</u></b> <ul style="list-style-type: none"> <li>• May model a box as a placement holder. Details is to be drawn by Specialised PE.</li> <li>• Retention Tank</li> <li>• RC Trench</li> </ul>
		<b><u>Sewer Network</u></b> <ul style="list-style-type: none"> <li>• Minor Sewer (when applicable)</li> </ul>
		<b><u>Drainage Network</u></b> <ul style="list-style-type: none"> <li>• C&amp;S: Effective tank capacity and other hydraulic details associated with the tank</li> <li>• M&amp;E: For pumped detention tank, M&amp;E to provide pump details</li> </ul>
		<b><u>Proposed Treatment of Common Drain</u></b> <ul style="list-style-type: none"> <li>• Longitudinal / sectional profile</li> <li>• Side gates</li> </ul>

Agency		Requirement Category
BCA		<ul style="list-style-type: none"> <li>• Lift and Escalator Provision (Number)</li> <li>• Location of passenger and Accessible Lifts (including platform and stair lifts)</li> </ul>
		<ul style="list-style-type: none"> <li>• <b><u>2D Drawings limited to:</u></b> <ul style="list-style-type: none"> <li>○ Buttons, Handrail, Marking of Maneuvring Space</li> </ul> </li> </ul>

Agency		Requirement Category
BCA		<p><b><u>Note: These requirements are currently optional and will only be required for regulatory compliance when LPS plan submission is mandated</u></b></p> <p><b><u>2D Drawings</u></b></p> <ul style="list-style-type: none"> <li>• Location of air-termination system, down conductors, earth electrodes</li> <li>• Zone of lightning protection provided by the air-termination network for open roof spaces and the sides of the building</li> <li>• Location of the points where there is equipotential bonding between the air-termination system, down-conductor system and earthed termination system; and</li> <li>• Location of the points where there is equipotential bonding of the lightning protection system to electrically conductive parts of the building except M&amp;E services.</li> </ul> <p><b><u>Supporting Documents:</u></b></p> <ul style="list-style-type: none"> <li>a) Material specification, photo, ppt, excel, words, etc. should be submitted</li> </ul>

# G2 Construction Gateway

Legend: ■ Architecture ■ C&S ■ M&E IFC COMPONENT

Materials	
Agency	Requirement Category
BCA	<ul style="list-style-type: none"> <li>Use of Glass at height</li> <li>Daylight Reflectance</li> </ul>

Mechanical Ventilation & Smoke Control System	
Agency	Requirement Category
SCDF <span style="border: 1px solid gray; border-radius: 15px; padding: 2px 5px;">SPACE</span>	<p><b><u>QP to declare at those functional space which are provided with the following Ventilation System(s):</u></b></p> <ul style="list-style-type: none"> <li>Natural ventilation (NV)</li> <li>Mechanical ventilation (MV)*</li> <li>Pressurisation*</li> <li>Cross-ventilation</li> <li>Cross-ventilation with intermediate - ventilation opening</li> <li>Vapour extraction system (spray painting booth)</li> </ul> <p><i>Note: Details to be provided and submitted by M&amp;E in Mechanical Ventilation (MV) Plan under Independent Submissions</i></p>

Night Lighting	
Agency	Requirement Category
URA	<p> <b><u>Night Lighting Report</u></b></p> <ul style="list-style-type: none"> <li>Detailed concept and renders</li> <li>Specifications</li> <li>Fixture installation</li> </ul>

ORA / ODA / Kiosks	
Agency	Requirement Category
URA	<ul style="list-style-type: none"> <li>Location and extent, detailed design</li> </ul>



# Construction Gateway

Legend:  Architecture  C&S  M&E IFC COMPONENT

Performance Based Projects	
Agency	Requirement Category
SCDF	<p><b>For projects with Performance-Based approach</b>                      QP to submit 2-D plans clearly indicating the rooms/spaces to be approved in Performance-Based submission.</p> <p><b>Performance-Based (PB) Plan Approval Process</b></p> <ul style="list-style-type: none"> <li>For approval process, refer to <a href="https://www.scdf.gov.sg/home/fire-safety/plans-and-consultations/performance-based-approach-to-fire-safety-design/performance-based-plan-approval-process">https://www.scdf.gov.sg/home/fire-safety/plans-and-consultations/performance-based-approach-to-fire-safety-design/performance-based-plan-approval-process</a>.</li> <li>In general, FEDB IPA should be obtained before CG submission and FER should be submitted together with Building Plan during CG submission. This approach strives to minimise any major reworks in the later stages of development. For complex cases in which the FEDB IPA could not be obtained before CG submission, the CG submission may still proceed with the following conditions:                             <ul style="list-style-type: none"> <li>While the CG submission may proceed concurrently with the FEDB review, the FEDB IPA will need to be obtained before issuance of CG clearance.</li> <li>If the project team is not ready with the FER during CG submission, the QP will need to exclude the affected PB fire safety works from the application and declare that no affected PB fire safety works would be carried out until FER approval is obtained. The FER should subsequently be submitted as an amendment to CG to obtain approval for the relevant PB fire safety works.</li> </ul> </li> </ul>

Pollution Control			
Agency	Requirement Category		
NEA	<p><b>COPPC - Section 2 : Judicious Siting of Industries and Other Development</b></p> <p>4. Objective</p> <table border="0" style="width: 100%;"> <tr> <td style="vertical-align: top;"> <p><b>When to apply:</b></p> <ul style="list-style-type: none"> <li>Applicants should provide the above information (either in 2D, 3D or supporting documents) and should be concluded by Construction Gateway (G2).</li> </ul> </td> <td style="vertical-align: top; padding-left: 20px;"> <p><b>Who to submit:</b></p> <ul style="list-style-type: none"> <li>QP appointed should submit the above information and keep other relevant QPs in the loop.</li> <li>The same QP should follow through the submissions for all gateways.</li> </ul> </td> </tr> </table>	<p><b>When to apply:</b></p> <ul style="list-style-type: none"> <li>Applicants should provide the above information (either in 2D, 3D or supporting documents) and should be concluded by Construction Gateway (G2).</li> </ul>	<p><b>Who to submit:</b></p> <ul style="list-style-type: none"> <li>QP appointed should submit the above information and keep other relevant QPs in the loop.</li> <li>The same QP should follow through the submissions for all gateways.</li> </ul>
<p><b>When to apply:</b></p> <ul style="list-style-type: none"> <li>Applicants should provide the above information (either in 2D, 3D or supporting documents) and should be concluded by Construction Gateway (G2).</li> </ul>	<p><b>Who to submit:</b></p> <ul style="list-style-type: none"> <li>QP appointed should submit the above information and keep other relevant QPs in the loop.</li> <li>The same QP should follow through the submissions for all gateways.</li> </ul>		

# Section 3: Specific Requirements by Key Gateways

## Construction Gateway

INTRODUCTION TO CX

GENERAL REQUIREMENTS

REGULATORY AGENCIES

**KEY GATEWAYS**

OTHER BUILDING WORKS

BIM DATA REPRESENTATION

G2

## Construction Gateway

Legend:



Architecture



C&S



M&E

IFC COMPONENT

### Pollution Control *(continued from previous page)*

Agency	Requirement Category
NEA  <i>(continued from previous page)</i>	<p><b><u>COPPC - Section 3 : Requirements for Industries</u></b></p> <p>5. Clean Industry 6. Light Industry</p> <p><b>When to apply:</b></p> <ul style="list-style-type: none"> <li>Applicants should provide the above information (either in 2D, 3D or supporting documents) and should be concluded by Construction Gateway (G2)</li> </ul> <p>7. General Industry 8. Special Industry</p> <p><b>Who to submit:</b></p> <ul style="list-style-type: none"> <li>QP appointed should submit the above information and keep other relevant QPs in the loop.</li> <li>The same QP should follow through the submissions for all gateways.</li> </ul>
	<p><b><u>COPPC - Section 4 : Requirements to Operate a Factory</u></b></p> <p>9. Use of Industrial premises 10. Trade effluent discharge into public sewer and watercourse</p> <p><b>When to apply:</b></p> <ul style="list-style-type: none"> <li>Applicants should provide the above information (either in 2D, 3D or supporting documents) and should be concluded by Construction Gateway (G2)</li> </ul> <p><b>Who to submit:</b></p> <ul style="list-style-type: none"> <li>QP appointed should submit the above information and keep other relevant QPs in the loop.</li> <li>The same QP should follow through the submissions for all gateways.</li> </ul>
	<p><b><u>COPPC - Section 5 : Pollution Control Requirements</u></b></p> <ul style="list-style-type: none"> <li>11. Water Pollution</li> <li>12. Air Pollution</li> <li>13. Noise Pollution</li> </ul> <p><b>When to apply:</b></p> <ul style="list-style-type: none"> <li>Applicants should provide the above information (either in 2D, 3D or supporting documents) and should be concluded by Construction Gateway (G2)</li> </ul> <p><b>Who to submit:</b></p> <ul style="list-style-type: none"> <li>QP appointed should submit the above information and keep other relevant QPs in the loop.</li> <li>The same QP should follow through the submissions for all gateways.</li> </ul>
	<p><b><u>COPPC - Section 6 : Hazardous Substances and Toxic Industrial Waste Control Requirements</u></b></p> <ul style="list-style-type: none"> <li>14. Hazardous Substances</li> <li>15. Toxic Industrial Waste</li> </ul> <p><b>When to apply:</b></p> <ul style="list-style-type: none"> <li>Applicants should provide the above information (either in 2D, 3D or supporting documents) and should be concluded by Construction Gateway (G2)</li> </ul> <p><b>Who to submit:</b></p> <ul style="list-style-type: none"> <li>QP appointed should submit the above information and keep other relevant QPs in the loop.</li> <li>The same QP should follow through the submissions for all gateways.</li> </ul>

### Public Space

Agency	Requirement Category
URA  SPACE	<p><b><u>Privately-Owned Public Spaces (POPS):</u></b></p> <ul style="list-style-type: none"> <li>Area verging of POPS</li> <li>Seating (design, no., location)</li> <li>Amenities (type, location)</li> <li>Signage (design, location)</li> <li>Outdoor Refreshment Areas (ORA) (if provided, location / extent)</li> </ul>

# Section 3: Specific Requirements by Key Gateways

## Construction Gateway

INTRODUCTION TO CX

GENERAL REQUIREMENTS

REGULATORY AGENCIES

**KEY GATEWAYS**

OTHER BUILDING WORKS

BIM DATA REPRESENTATION



# G2 Construction Gateway

Legend:  Architecture  C&S  M&E IFC COMPONENT

### Public/Transit Shelter (PS/TS)

Agency	Requirement Category
<div style="background-color: orange; width: 100%; height: 100%;"></div> <div style="background-color: green; width: 100%; height: 100%;"></div>	<p><b>BCA</b></p> <p><b>Building Plan (Architecture)</b> The following shall be clearly illustrated in the submission:</p> <ul style="list-style-type: none"> <li>- Entrance area layout leading from opening at ground level (or elsewhere) to the EHD and PT door, including firemen staircases and exit routes.</li> <li>- Strike point lines and distance measured between strike points and the EHD/PT doors.</li> <li>- All wall and slab thickness</li> <li>- All air shafts and bomb pit layouts with dimensions, from opening at ground (or elsewhere) to the plantroom interface.</li> <li>- Location and demarcation of all dry toilet areas, net areas occupied by each cluster of dry toilets, cubicles, floor trap etc.</li> <li>- Demarcate net shelter area at each level, indicate the calculated areas and shelter size category in the plans.</li> <li>- Blast, blast and gas, and gas protected walls and slabs shall be highlighted with differentiated hatching and/or colours in a consistent manner.</li> </ul> <p><b>Structural Plan (C&amp;S)</b> The following shall be clearly illustrated in the submission:</p> <ul style="list-style-type: none"> <li>- Entrance area layout leading from opening at ground level (or elsewhere) to the EHD and PT door, including firemen staircases and exit routes.</li> <li>- Strike point lines and distance measured between strike points and the EHD/PT doors.</li> <li>- Line load design and reinforcement details for support structures of CD doors.</li> <li>- All RC wall and slab thicknesses</li> </ul>

### Roofscape

Agency	Requirement Category
<div style="background-color: orange; width: 100%; height: 100%;"></div>	<p><b>URA</b></p> <ul style="list-style-type: none"> <li>• Screening details of M&amp;E equipment, where required</li> <li>• Use of RC Flat Roofs – Indicate whether roof is accessible, and if so, for what purpose</li> <li>• Structures (If any)</li> </ul>

### Rapid Transit System (RTS) Station

Agency	Requirement Category
<div style="background-color: orange; width: 100%; height: 100%;"></div> <div style="border: 1px solid gray; border-radius: 10px; padding: 5px; margin: 5px; text-align: center;">SPACE</div> <div style="border: 1px solid gray; border-radius: 10px; padding: 5px; margin: 5px; text-align: center;">SITE</div> <div style="border: 1px solid gray; border-radius: 10px; padding: 5px; margin: 5px; text-align: center;">SITE BOUNDARY</div> <div style="border: 1px solid gray; border-radius: 10px; padding: 5px; margin: 5px; text-align: center;">ACCESSIBLE ROUTE</div>	<p><b>URA</b></p> <p><b>Urban Design Requirements</b></p> <ul style="list-style-type: none"> <li>• Design and location of at-grade bicycle parking</li> </ul> <p><b>Draft Development Interface Report</b></p> <ul style="list-style-type: none"> <li>• For works interfacing with existing / future connection</li> <li>• Architectural information for future developer (e.g. fire safety requirements; Knock Out Panels (KOP))</li> <li>• Structural information for future developer (e.g. Loading requirements)</li> <li>• Mechanical and Electrical (M&amp;E) information for future developer (e.g. ventilation shaft location and throw)</li> <li>• Details of Loading Provision</li> </ul> <p><i>Note: Coordinated by Architect, with inputs from respective engineers</i></p>

**G2**

# Construction Gateway

Legend: ■ Architecture ■ C&S ■ M&E IFC COMPONENT

Signage	
Agency	Requirement Category
URA	<p><b><u>Privately-Owned Public Spaces (POPS), Through Block Link (TBL) Signage</u></b></p> <ul style="list-style-type: none"> <li>Location and size of signages</li> </ul>

Site Layout only	
Agency	Requirement Category
<p>NParks</p> <p>PLANTING AREA</p> <p>GREEN VERGE</p>	<p><b><u>Provision of Planting Areas / Green Verges</u></b></p> <ul style="list-style-type: none"> <li>To ensure dimensions of planting areas are compliant with NParks Guidelines (Chapter 3) or as approved by NParks during Design Gateway (G1)</li> </ul>
<p>URA</p> <p>SITE BOUNDARY</p> <p>SITE</p>	<p><b><u>Building Setback from Boundary</u></b></p> <ul style="list-style-type: none"> <li>Setback for Building Appendages – Location and width</li> <li>Treatment for non-compliant Multi-Storey Car Parks and Ancillary Structures</li> </ul>

Site Layout, Basement	
Agency	Requirement Category
<p>URA</p> <p>SITE</p>	<p><b><u>Basements</u></b></p> <ul style="list-style-type: none"> <li>Basement protrusion (if any) and location within site</li> <li>Screening of basement opening</li> </ul>

Site Layout, Landscape Deck	
Agency	Requirement Category
<p>URA</p> <p>PLANTING AREA</p> <p>PLANTER BOX</p> <p>SPACE</p> <p>LANDSCAPE PLANTS</p>	<p><b><u>Landscape Deck</u></b></p> <ul style="list-style-type: none"> <li>Exposure of Basement Wall &amp; Proposed Treatment (Berm / Vertical Greenery)</li> <li>Site Coverage on Landscape Deck – declare %</li> <li>Provision of Greenery on Deck – Location and %</li> <li>Boundary Wall Porosity – declare % and show design</li> </ul>

Site Layout, Security Screening	
Agency	Requirement Category
URA	<p><b><u>Security Screening (where required)</u></b></p> <ul style="list-style-type: none"> <li>If the site falls within a special control area, it will need to comply with security screening requirements, if any</li> </ul>

# G2 Construction Gateway

Legend: ■ Architecture ■ C&S ■ M&E IFC COMPONENT

Site Layout, Street Works	
Agency	Requirement Category
LTA CULVERT RAMP ROAD	<b>Access Point Details</b> <ul style="list-style-type: none"> <li>Structural details of entrance culvert at access points (reinforcement, connection to entrance approach etc.)</li> <li>Levels, gradient, cross-fall</li> <li>Redundant access to be sealed and reinstated to match existing side-table</li> </ul>
	<b>Proposed Pick-Up / Drop-Off Points (Within Development): PUDO details</b> <ul style="list-style-type: none"> <li>All details presented at Design Gateway (G1) stage</li> </ul>
	<b>Street Works Deposit</b> <ul style="list-style-type: none"> <li>For private developments with proposed major road infrastructure works (e.g. new streets, major improvement of an existing street, POB, UPN), an amount to be deposited with LTA for the execution and completion of the proposed street works</li> </ul>

Site Layout, Vehicular Parking	
Agency	Requirement Category
LTA RAMP ROAD PARKING LOT	<b>Vehicular Parking Provision</b> <ul style="list-style-type: none"> <li>To provide the details and critical dimensions of the parking layout such as:                             <ul style="list-style-type: none"> <li>Type and size of parking lots</li> <li>Width of ramps and accessways</li> <li>Inner turning radius and width of turning paths</li> <li>Width of parking aisles</li> <li>Gradient of vehicular ramps</li> <li>Headroom clearance</li> <li>Road and traffic arrow markings</li> <li>Bicycle rack details</li> <li>EV lots &amp; charging stations</li> </ul> </li> </ul>

Site Planning & External Firefighting Provisions	
Agency	Requirement Category
SCDF WINDOW ROAD SPACE SIGNAGE	<b>Fire Access Opening</b> <ul style="list-style-type: none"> <li>Compliance of provision of fire access opening</li> <li>Location, signage &amp; size</li> <li>Number and position of access opening</li> <li>Exemption of fire access opening</li> </ul>
	<b>Fire Command Centre (FCC)</b> <ul style="list-style-type: none"> <li>FCC shall be provided if building requires:                             <ul style="list-style-type: none"> <li>Fire lift</li> <li>Emergency voice communication system</li> <li>Engineered smoke control system</li> </ul> </li> <li>Size and Location of FCC</li> <li>Ventilation system for FCC</li> <li>Supporting equipment allow in FCC</li> </ul>



# G2 Construction Gateway

Legend:  Architecture  C&S  M&E IFC COMPONENT

Site Planning & External Firefighting Provisions <i>(continued from previous page)</i>	
Agency	Requirement Category
<div style="background-color: orange; width: 20px; height: 100%;"></div> <p>SCDF</p> <p><i>(continued from previous page)</i></p>	<p><b><u>Fire Engine Accessway / Access Road</u></b></p> <ul style="list-style-type: none"> <li>• Compliance of fire engine access road requirements of PG I to VIII and mixed-use buildings:               <ul style="list-style-type: none"> <li>○ Indicate road serving as fire engine access road within the project boundary. To indicate on plan if public road is used as fire engine access road.</li> <li>○ Compliance of width, turning radii/ facilities, design load capacity, gradient, overhead clearance.</li> <li>○ Marking and signpost along fire engine access road.</li> <li>○ Compliance of no obstruction along fire engine access road</li> <li>○ Basement: Compliance of fire engine access road within a travel distance of 18m to the entrance of all exit staircases where landing valves (dry or wet riser) are provided.</li> </ul> </li> <li>• Compliance of fire engine accessway requirements for PG II to VIII and mixed-use buildings:               <ul style="list-style-type: none"> <li>○ Indicate road serving as fire engine accessway within the project boundary. To indicate on plan if public road is used as fire engine accessway.</li> <li>○ Compliance of width and length of fire engine accessway. To submit separate calculations for the required length of fire engine accessway</li> <li>○ Compliance of turning radii/ facilities, design load capacity, gradient, overhead clearance</li> <li>○ Marking and signpost along fire engine accessway</li> <li>○ Compliance of no obstruction along and above fire engine accessway</li> <li>○ Basement: Compliance of fire engine accessway within a travel distance of 18m to the entrance of all exit staircases where landing valves (dry or wet riser) are provided.</li> </ul> </li> </ul>

Smoke Control System declaration	
Agency	Requirement Category
<div style="background-color: orange; width: 20px; height: 100%;"></div> <p>SCDF</p>	<p><b><u>QP to declare at those functional space which are provided with the following smoke control System(s):</u></b></p> <ul style="list-style-type: none"> <li>• Ductless Jet Fan System ^</li> <li>• Engineered Smoke Control System^</li> <li>• Smoke Purging System^</li> <li>• Smoke vent</li> </ul> <p>^: Details to be provided and submitted by M&amp;E QP in Mechanical Ventilation (MV) Plan under Independent Submissions.</p>

Staircase	
Agency	Requirement Category
<div style="display: flex; align-items: center;"> <div style="background-color: orange; width: 20px; height: 20px; margin-right: 5px;"></div> <div style="background-color: green; width: 20px; height: 20px; margin-right: 5px;"></div> <div style="border: 1px solid gray; border-radius: 10px; padding: 2px 5px; margin-right: 10px;">STAIRCASE</div> <div style="border: 1px solid gray; border-radius: 10px; padding: 2px 5px;">RAILING</div> </div> <p>BCA</p>	<ul style="list-style-type: none"> <li>• Minimum Width,</li> <li>• Tread and Riser, Handrail / Railing</li> </ul>

**G2**

# Construction Gateway

Legend:  Architecture  C&S  M&E IFC COMPONENT

Statistical Gross Floor Area (SGFA)	
Agency	Requirement Category
BCA	<p>SGFA refers to the total floor area of a building, regardless of the usage of the space.</p> <p>Details of SGFA computation can be found in the SGFA Form BCA-BP-SGFA. The updated SGFA Form can be downloaded at <a href="https://go.gov.sg/sgfa">https://go.gov.sg/sgfa</a>.</p> <ul style="list-style-type: none"> <li>Provision of General Building SGFA for below and above sublevels.</li> <li>Provision of Specified Building SGFA for below and above sublevels.</li> <li>Form BCA-BP-SGFA</li> </ul> <p><b>Additional Supporting Documents:</b>                      Where any of the above SGFA cannot be modelled in BIM, 2D SGFA plans can be submitted :</p> <p><b>Site Plan</b> – SGFA Table with information on SGFA for General Building and Specified Building at below sublevel and above sublevel. For amendment plan, SGFA Table should include SGFA (Approved), Changes (+/-) and SGFA (Proposed).</p> <p><b>Floor Plan</b> – To indicate General and Specified Building SGFA at below sublevel and above sublevel.</p>

Structural Design	
Agency	Requirement Category
<p>BCA</p> <div style="display: flex; flex-wrap: wrap; gap: 5px;"> <div style="border: 1px solid gray; border-radius: 10px; padding: 2px 5px; margin: 2px;">BOREHOLE</div> <div style="border: 1px solid gray; border-radius: 10px; padding: 2px 5px; margin: 2px;">PILE</div> <div style="border: 1px solid gray; border-radius: 10px; padding: 2px 5px; margin: 2px;">FOOTING / PILECAP</div> <div style="border: 1px solid gray; border-radius: 10px; padding: 2px 5px; margin: 2px;">SLAB</div> <div style="border: 1px solid gray; border-radius: 10px; padding: 2px 5px; margin: 2px;">BEAM</div> <div style="border: 1px solid gray; border-radius: 10px; padding: 2px 5px; margin: 2px;">COLUMN</div> <div style="border: 1px solid gray; border-radius: 10px; padding: 2px 5px; margin: 2px;">STAIRCASE</div> <div style="border: 1px solid gray; border-radius: 10px; padding: 2px 5px; margin: 2px;">WALL</div> </div>	<p><b>Structural Design (Piling and Foundation Works)</b></p> <p><i>Can be provided at Piling Gateway (G1.5) or Construction Gateway (G2)</i></p> <ul style="list-style-type: none"> <li><b>Piling &amp; Foundation Works IFC-SG model</b></li> <li><b>Ground Investigation:</b> <ul style="list-style-type: none"> <li>Compliance with minimum number of borehole required as stipulated in Circular APPBCA-2016-08</li> </ul> </li> <li><b>2D Drawings limited to:</b> <ul style="list-style-type: none"> <li>General notes</li> <li>Irregular Pilecap / Footing Details</li> </ul> </li> </ul> <p> <b>Design Calculation Reports:</b></p> <ol style="list-style-type: none"> <li>From QP, AC, [QP(Geo) &amp; AC (Geo), if needed]</li> </ol> <p> <b>Additional Supporting Documents:</b></p> <ol style="list-style-type: none"> <li>Site investigation report in PDF &amp; AGS format</li> <li>Impact assessment report</li> <li>Topography</li> <li>Complete set of structural framing plan for reference</li> <li>Complete set of building plan for reference</li> <li>Completion letter of pre-consultation (for complex structure only)</li> </ol>



**G2**

# Construction Gateway

Legend:  Architecture  C&S  M&E IFC COMPONENT

Structural Design <i>(continued from previous page)</i>	
Agency	Requirement Category
BCA  <i>(continued from previous page)</i>	<ul style="list-style-type: none"> <li>• <b>Complete set of IFC-SG model(s)</b> for all structural elements &amp; details</li> <li>• <b><u>2D Drawings limited to:</u></b> <ul style="list-style-type: none"> <li>○ General notes</li> <li>○ Special details (e.g. slab reinforcement detailing, complex structure detailing, transfer plate detailing, irregular section detailing, precast joints, prestressed details, steel connections.)</li> </ul> </li> <li> <b><u>Design Calculation Reports:</u></b> <ul style="list-style-type: none"> <li>• From QP, AC, [QP(Geo) &amp; AC (Geo), if needed]]</li> </ul> </li> <li> <b><u>Additional Supporting Documents:</u></b> <ol style="list-style-type: none"> <li>a) Site investigation report in PDF &amp; AGS format</li> <li>b) Impact assessment report</li> <li>c) Topography</li> <li>d) Complete set of building plan submitted simultaneously</li> <li>e) Completion letter of pre-consultation (for complex structure only)</li> </ol> </li> </ul>

Structural Fire Precautions	
Agency	Requirement Category
SCDF  <div style="display: flex; flex-wrap: wrap; gap: 5px;"> <div style="border: 1px solid gray; border-radius: 10px; padding: 2px 10px; margin: 2px;">SLAB</div> <div style="border: 1px solid gray; border-radius: 10px; padding: 2px 10px; margin: 2px;">WALL</div> <div style="border: 1px solid gray; border-radius: 10px; padding: 2px 10px; margin: 2px;">LIFT</div> <div style="border: 1px solid gray; border-radius: 10px; padding: 2px 10px; margin: 2px;">STAIRCASE</div> <div style="border: 1px solid gray; border-radius: 10px; padding: 2px 10px; margin: 2px;">DOOR</div> <div style="border: 1px solid gray; border-radius: 10px; padding: 2px 10px; margin: 2px;">SPACE</div> <div style="border: 1px solid gray; border-radius: 10px; padding: 2px 10px; margin: 2px;">DAMPER</div> </div>	<div style="border-bottom: 1px solid black; padding-bottom: 5px;"> <b><u>Compartmentation</u></b> <ul style="list-style-type: none"> <li>• Compliance of compartmentation requirements:                             <ul style="list-style-type: none"> <li>○ Area and cubical extent to comply with Table 3.2A (for buildings not protected with sprinkler system)</li> <li>○ Maximum of 3 storeys per compartment when habitable height is not exceeding 24m</li> <li>○ Maximum of 1 storey per compartment when habitable height exceeds 24m</li> </ul> </li> <li>• Compliance of compartmentation requirements for Atrium space</li> <li>• Compliance of compartmentation requirements for High hazard occupancy</li> </ul> </div> <div style="border-bottom: 1px solid black; padding: 5px 0 5px 20px;"> <b><u>Compartmentation Walls and Compartmentation Floors</u></b> <ul style="list-style-type: none"> <li>• Compliance of requirements for compartment walls or compartment floors:                             <ul style="list-style-type: none"> <li>○ Fire resistance rating</li> <li>○ Non-combustible</li> </ul> </li> <li>• Use of fire shutter as compartment wall</li> <li>• Room / space allows the use of fire rated roller shutter</li> </ul> </div> <div style="padding: 5px 0 5px 20px;"> <b><u>External Wall</u></b> <ul style="list-style-type: none"> <li>• Compliance of requirements for external walls                             <ul style="list-style-type: none"> <li>○ Fire resistance rating</li> <li>○ Non-combustible</li> </ul> </li> <li>• Compliance of setback distance for unprotected opening</li> <li>• Compliance of external wall finishes</li> <li>• Compliance of vertical fire spread requirements</li> <li>• Exemption of fire resistance rating for non-load-bearing external wall</li> </ul> </div>

**G2**

# Construction Gateway

Legend:  Architecture  C&S  M&E IFC COMPONENT

Structural Fire Precautions <i>(continued from previous page)</i>	
Agency	Requirement Category
<p>SCDF</p> <p><i>(continued from previous page)</i></p>	<p><b>Element of Structure</b></p> <ul style="list-style-type: none"> <li>• Compliance of element of structure requirements</li> <li>• Minimum periods of fire resistance in accordance with Table 3.3A</li> <li>• Exemption of fire resistance rating for single storey buildings</li> </ul> <p>• Compliance of requirements for the use of fire-rated board for protection to structural steel beams, columns</p> <hr/> <p><b>Protected Shafts</b></p> <ul style="list-style-type: none"> <li>• Compliance of services running inside and/or passing through fire lift lobby and smoke-free lobby</li> <li>• Compliance of gas pipe running inside an internal corridor / lobby</li> <li>• Prohibition of other services passing through FCC, fire pump room, emergency generator room &amp; smoke control fan room.</li> <li>• Compliance of roof construction requirements:                             <ul style="list-style-type: none"> <li>○ Surface spread of flame rating</li> <li>○ Composite panel as roofing covering</li> <li>○ Roof covering containing plastic</li> <li>○ Exemption of roof construction material</li> </ul> </li> <li>• Compliance of requirements for protected shaft:                             <ul style="list-style-type: none"> <li>○ Fire resistance rating</li> <li>○ Non-combustible</li> <li>○ Material of construction</li> <li>○ Opening in protected shaft</li> <li>○ Ventilation</li> <li>○ Fire resistance rating of doors in protected shaft</li> </ul> </li> <li>• Compliance of requirements for lift shaft:                             <ul style="list-style-type: none"> <li>○ Material of construction</li> <li>○ Exemption of enclosure in protected shaft located at edge of atrium</li> <li>○ Provision of protected lobby when lift is at basement</li> <li>○ Compliance of requirements for private lift for exclusive use of occupants in residential under PG II</li> </ul> </li> </ul> <p>• Compliance of protected shaft containing exit staircase:                             <ul style="list-style-type: none"> <li>○ Compartmentation of exit staircase with masonry or drywall construction</li> <li>○ Fire resistance of door opening into exit staircase</li> <li>○ Finishes within exit staircase shall be non-combustible</li> <li>○ Types of services allowed in exit staircase</li> </ul> </p> <p>• Compliance of protected shaft containing other services installations:                             <ul style="list-style-type: none"> <li>○ Electrical conduits / cable tray</li> </ul> </p> <hr/> <p><b>Separating Walls</b></p> <ul style="list-style-type: none"> <li>• Exemption of separating wall requirements for PG I &amp; II buildings</li> <li>• Compliance of Openings in separating wall requirements</li> <li>• Compliance of requirements for separating walls                             <ul style="list-style-type: none"> <li>○ Fire resistance rating</li> <li>○ Non-combustible</li> </ul> </li> </ul> <hr/> <p><b>Use of other fire rated material</b></p> <ul style="list-style-type: none"> <li>• Compliance of requirements on use of Fire rated board</li> <li>• Compliance of requirement on use of intumescent paint</li> <li>• Compliance of requirement on use of flame retardant chemicals</li> </ul>

# G2 Construction Gateway

Legend: ■ Architecture ■ C&S ■ M&E IFC COMPONENT

Structures in Building Setback, Green Buffer	
Agency	Requirement Category
URA	<ul style="list-style-type: none"> <li>Location (e.g. integrated with building envelope)</li> <li>Finish material of manhole to match paving if located within covered / open walkway)</li> </ul>

Use & Intensity	
Agency	Requirement Category
URA	<ul style="list-style-type: none"> <li>Gross Plot Ratio / Gross Floor Area</li> <li>Land Use / Building Uses – detailed breakdown by use and GFA quantum</li> </ul> <p>[Note: For time-being, submission of the native BIM models is required to facilitate GFA verification. The native models can be provided at the resubmission to CG i.e. where QPs expect to obtain Written Permission as part of CG Clearance]</p> <p><b>Bonus GFA Incentive Schemes:</b></p> <p>Balcony / Recreational / Transformation / Others – GFA quantum and %</p>

Vehicular Parking	
Agency	Requirement Category
BCA <span style="border: 1px solid gray; border-radius: 15px; padding: 2px 5px;">PARKING LOT</span>	<ul style="list-style-type: none"> <li>Provision of Accessible and Family Lot(s)</li> </ul>
URA <span style="border: 1px solid gray; border-radius: 15px; padding: 2px 5px;">PARKING LOT</span>	<ul style="list-style-type: none"> <li>Total number of parking lots (including motorcycle parking)</li> <li>Residual area within car park floors to be demarcated</li> <li>Screening details for vehicular parking and service areas</li> </ul>

Ventilation	
Agency	Requirement Category
BCA <span style="border: 1px solid gray; border-radius: 15px; padding: 2px 5px;">SPACE</span> <span style="border: 1px solid gray; border-radius: 15px; padding: 2px 5px;">PARKING LOT</span>	<ul style="list-style-type: none"> <li>Provision of Ventilation (Natural Ventilation for residential development)</li> <li>Minimum 5% opening for Natural Ventilation</li> <li>Maximum distance (12m) from Natural Ventilating opening</li> <li>Natural Ventilation (dimension of recess / airwell)</li> <li>Carpark Ventilation</li> </ul>

Washroom	
Agency	Requirement Category
BCA <span style="border: 1px solid gray; border-radius: 15px; padding: 2px 5px;">SANITARY APPLIANACES</span> <span style="border: 1px solid gray; border-radius: 15px; padding: 2px 5px;">SPACE</span>	<ul style="list-style-type: none"> <li>Sanitary provisions for wheelchair users (including accessible changing rooms) and ambulant disabled</li> <li>Sanitary provisions for young children</li> </ul>



# Construction Gateway

Legend:  Architecture  C&S  M&E IFC COMPONENT

Others	
Agency	Requirement Category
SCDF	<p><b><u>Other fire safety requirements</u></b></p> <p>QP shall refer to Chapter 9 for additional fire safety requirements for specific purpose groups and Chapter 10 for fire safety requirements for special installations.</p>
URA	<p> <b><u>Environmental Impact Assessment (where required)</u></b></p> <ul style="list-style-type: none"> <li>Submission of any other documents required</li> </ul>
	<p> <b><u>Supplementary Documents</u></b></p> <ul style="list-style-type: none"> <li>Previous approved plans (where requested by URA)</li> </ul>
	<p> <b><u>Public Communications Plans (if applicable)</u></b></p> <ul style="list-style-type: none"> <li>Distribution of flyers prior to CG submission and submission of relevant forms, where required</li> </ul>
	<p> <b><u>Form on Unit Information</u></b></p> <ul style="list-style-type: none"> <li>To provide a tabulation on unit-level information for each submission/resubmission at CG and TOP/CSC stage. More information will be available on the URA website under DC Supplementary Forms.</li> </ul>
	<p> <b><u>Design Advisory Panel (DAP) Report</u></b></p> <ul style="list-style-type: none"> <li>Urban design and architectural information for DAP to assess (e.g. renders; diagrams showing sheltered pedestrian route)</li> </ul>
	<p> <b><u>Pre-CG Submission: Stage 2 Design Advisory Panel – for selected projects</u></b></p> <ul style="list-style-type: none"> <li>The DAP materials submitted are to consist of :                             <ul style="list-style-type: none"> <li>Technical drawings (including a full set of plans, elevations and sections)</li> <li>Digital and hardcopy DAP booklets (including 2 hardcopies in A3), which should not exceed 50 pages, including appendices, attached drawings and plans, with a minimum font size of 12.</li> <li>Presentation slides. The number of presentation slides should be comfortable for a 20-minute presentation without lengthy text, highlighting the key points with further elaboration provided in the DAP booklet.</li> <li>Digital models</li> <li>Where necessary, a physical model of the proposed development will be required, at scale of 1:400 or smaller (to be advised by the officer in charge), showing context of site] will have to be submitted.</li> <li>Additional reports, such as Conservation Reports, are to be included as Appendices to the A3 booklets</li> </ul> </li> <li>The following aspects of the proposal will be assessed at this stage of the DAP:                             <ul style="list-style-type: none"> <li>Detailed building layout</li> <li>Detailed architectural treatment including appropriate use of building materials and finishes</li> <li>Night lighting design concept, including method statement and detailed drawings on how the night lighting intention would be achieved</li> <li>Detailed landscaping design including planting palette</li> <li>Detailed Design of Public Spaces</li> <li>Scaled elevations and sections of the relevant details (preferably 1:50 in hardcopy), digital architectural model of part(s) of the building (if necessary), as well as material samples of the façade and roof materials are required to be submitted to show the architectural design of the development</li> </ul> </li> </ul>

----- **End of Requirements for Construction Gateway (G2)** -----



## Independent Agency Submissions

Agency	Summary of Independent Agency Submissions	Common Gateway Key Words
<b>BCA</b>	<ul style="list-style-type: none"> <li>Structural design of localized works with design calculations of ancillary structures e.g. cladding, barrier</li> <li>Structural design of ancillary works and component such as demolition, temporary ERSS, barriers &amp; cladding, temporary traffic decking</li> <li>Building design details of specialized works such as</li> <li>Details of lift equipment and escalators</li> <li>Constructability Implementation Plan</li> <li>Environmental Sustainability Detailed Requirements</li> <li>Outdoor Advertising Sign or Signboard License</li> </ul>	<ul style="list-style-type: none"> <li>Buildability</li> <li>Connectivity</li> <li>Equipment</li> <li>Façade</li> <li>Environmental Sustainability</li> <li>Household / Storey Shelter</li> <li>Infra &amp; Utilities (Internal)</li> <li>Lightning Protection</li> <li>Public / Transit Shelter</li> <li>Signage</li> <li>Structural Design</li> </ul>
<b>LTA</b>	<p>Railway protection/Road structure protection details for engineering work/ restricted activities apart from aspects cleared in Piling Gateway / Construction Gateway:</p> <ul style="list-style-type: none"> <li>Plan for engineering works</li> <li>Engineering evaluation report</li> <li>Instrumentation proposal</li> <li>Method statement of work</li> <li>Emergency procedure</li> </ul>	<ul style="list-style-type: none"> <li>Impact Studies</li> <li>Rail Protection</li> <li>Road Structure Protection</li> <li>Site Layout</li> </ul>
<b>NEA</b>	<ul style="list-style-type: none"> <li>Temporary Sanitary Facilities at Construction site</li> <li>Detailed Plan on Pollution Control Equipment, Pollution Control Study (PCS)</li> <li>Noise Impact Assessment (NIA)</li> </ul>	<ul style="list-style-type: none"> <li>Noise Control</li> <li>Pollution Control</li> <li>Vehicular Parking</li> </ul>
<b>NParks</b>	<ul style="list-style-type: none"> <li>Planting/Landscaping scheme of planting areas within development, including open air parking areas at street level, and of green verges along roadside (i.e. number and species of trees and plants to be planted)</li> <li>Details of new tree planting and reinstatement works for green verge affected by entrance culvert</li> </ul>	<ul style="list-style-type: none"> <li>Greenery</li> </ul>
<b>PUB</b>	<ul style="list-style-type: none"> <li>Application for specified activities near Water and Sewer pipes</li> <li>Earth Control Measures (ECM)</li> <li>Temporary works affecting drainage/within drainage reserve (e.g. drain diversion, soil investigation works)</li> <li>Notification and completion of minor sewer/sanitary works</li> <li>Notification and CSC of Water Service Installation works</li> <li>Notification and CSC of Water Service Installation Works involves pumping equipment or water tank (site plans, water reticulation schematic/layout drawing of WSI design works, water requirements, SP Water Utilities Account number)</li> </ul> <p>Separate submission may be made for Rainwater Collection System in developments for non-potable water use</p>	<ul style="list-style-type: none"> <li>Infra &amp; Utilities (Internal)</li> <li>Water Supply</li> </ul>

See also:  
[Latest CORENET X Circulars](#)



## Independent Agency Submissions

Agency	Summary of Independent Agency Submissions	Common Gateway Key Words
<b>SCDF</b>	<p><b><u>Air-Conditioning, Mechanical Ventilation and Fire Protection Plan (MV &amp; FP)</u></b></p> <ul style="list-style-type: none"> <li>Detailed layout and floor plan showing Fire Protection and Mechanical Ventilation system of development</li> <li>Key features of the building in which the system is to be installed</li> <li>Schematic diagram of the overall system showing clearly the key features and their functions, relative locations in the building, lots, sizes, capacities and other essential information incl. the air distribution design arrangement in the case of air-conditioning and mechanical ventilation systems</li> <li>Layout of the system on every floor plan showing clearly the various parts and their functions, locations, arrangements, sizes, capacities and other essential information</li> <li>Necessary cross-sectional views as superimposed on the building or part thereof to fully describe the details and configurations of the system</li> <li>A colour scheme to clearly distinguish the various distinct parts of the system and the different systems from one another</li> <li>Volumetric rate of flow of air at each point of inlet and outlet of each system including those serving protected staircases, exit passageways, lobbies, areas of refuge, the Fire Command Centre, fire pump rooms, generator rooms, rooms used for the storage of flammable liquids or gas or other areas of special risk;</li> <li>Location of: <ul style="list-style-type: none"> <li>Fire compartment walls, floors, air shafts, fire dampers, smoke detectors and other fire precautionary features</li> <li>Automatic Fire Alarm System</li> <li>Automatic Fire Extinguishing System</li> <li>Emergency Voice Communication System</li> <li>Smoke Control System</li> <li>Calculations and reports (where applicable)</li> </ul> </li> </ul>	<ul style="list-style-type: none"> <li>Equipment</li> <li>Fire Compartmentation</li> <li>Fire Fighting</li> <li>Materials</li> </ul>
<b>URA</b>	<ul style="list-style-type: none"> <li>Painting (for conserved buildings)</li> <li>Signage (for conserved buildings)</li> </ul>	<ul style="list-style-type: none"> <li>Conservation</li> <li>Demolition</li> </ul>
Agency	Summary of Independent Agency Submissions	Common Gateway Key Words
<b>SLA + URA</b>	<p><b><u>Strata / Land Subdivision and/or Amalgamation</u></b></p> <ul style="list-style-type: none"> <li>As-built plans and/or 3D cadastre model. More details will be released in future regarding the latter.</li> </ul>	-

See also:  
[Latest CORENET X Circulars](#)





# Independent Agency Submissions

Legend: ■ Architecture ■ C&S ■ M&E  Builder IFC COMPONENT

## Constructability

	Agency	Requirement Category
	BCA	<p><b>Constructability Implementation Plan (CIP)</b></p> <ul style="list-style-type: none"> <li>BIM Plans which describe and define the type, extent of use and details of the system framework</li> </ul> <p> <b>Supporting Documents for CIP:</b></p> <p>a) Documents (e.g. photos, 2D plans, etc.) on the use of construction techniques, processes, plant, equipment and innovative methods</p> <p> <b>Constructability Score (C-Score)</b></p> <p>a) C-Score Calculations (to be computed and submitted by Builder in PDF format)</p>

## Conservation

	Agency	Requirement Category
	URA	<a href="#">Refer to URA Conservation Requirements here</a>

## Demolition Works (For noting)

	Agency	Requirement Category
	URA	<p>If developers intend to proceed with demolition works ahead of obtaining DSP or DG Clearance, a demolition application for the demolition works will be required, accompanied by the payment of requisite fees to both URA and BCA.</p> <p>URA will not require a separate demolition application if the works to be demolished are :</p> <ul style="list-style-type: none"> <li>Shown within the proposal granted planning permission, or</li> <li>A lodgment application has been made and URA's authorisation letter has been granted for a new erection or a reconstruction proposal that necessitates the demolition of any existing building structures.</li> </ul>

## Environmental Sustainability

	Agency	Requirement Category
	BCA	<p><b>Major Energy Use Change during Operation</b></p> <ul style="list-style-type: none"> <li>Design and As-built clearance for major energy use change.</li> <li>For more information, please refer to Code on Environmental Sustainability Measures for Existing Building: <a href="https://www1.bca.gov.sg/buildsg/sustainability/regulatory-requirements-for-existing-buildings">https://www1.bca.gov.sg/buildsg/sustainability/regulatory-requirements-for-existing-buildings</a></li> </ul> <p><b>Periodic Energy Audit during Operation</b></p> <ul style="list-style-type: none"> <li>Submission of Periodic Energy Audit</li> <li>For more information, please refer to: <a href="https://www1.bca.gov.sg/buildsg/sustainability/regulatory-requirements-for-existing-buildings/mandatory-submission-of-periodic-energy-audits">https://www1.bca.gov.sg/buildsg/sustainability/regulatory-requirements-for-existing-buildings/mandatory-submission-of-periodic-energy-audits</a></li> </ul>

## Greenery

	Agency	Requirement Category
	NParks	<p><b>Planting Scheme (within Development Boundary)</b></p> <ul style="list-style-type: none"> <li>To show location, number and species of existing and proposed trees / shrubs for planting areas</li> </ul>



# Independent Agency Submissions

Legend:  Architecture  C&S  M&E IFC COMPONENT

Impact Studies only	
Agency	Requirement Category
NEA	<p> <b>Noise Impact Assessment (NIA-Post) for Land Traffic Noise</b></p> <p>NIA (Post) report will be required for (1) <u>New</u> residential and noise sensitive developments located within 70m of <u>existing</u> land traffic noise sources/hotspots (e.g. expressways/major arterial roads/MRT tracks) on existing residential and (2) <u>Existing</u> noise sensitive developments located within 70m of <u>new</u> transport-related developments (e.g. expressway/major arterial roads/MRT tracks/bus interchanges/ bus depots), inclusive of the expansion of existing transport-related infrastructures</p> <p><b>When to apply:</b></p> <ul style="list-style-type: none"> <li>Applicant will need to submit NIA (Post) report to NEA directly via email to <a href="mailto:DCLD_consultation@nea.gov.sg">DCLD_consultation@nea.gov.sg</a> before Completion Gateway (G3) and concluded before TOP can be granted..</li> <li>Sufficient time shall be catered for NEA to process the NIA (Post)</li> <li>The processing of NIA (Post) will take 1-2 months</li> </ul> <p><b>Who to submit:</b></p> <ul style="list-style-type: none"> <li>QP appointed should submit the above information and keep other relevant QPs in the loop.</li> <li>The same QP should follow through the submissions for all gateways.</li> </ul>
	<p> <b>Noise Report for ACMV</b></p> <p>Noise report for ACMV will be required for non-industrial developments which have new air-conditioning and mechanical ventilation works, including relocations.</p> <p><b>When to apply:</b></p> <ul style="list-style-type: none"> <li>Applicant will need to submit ACMV noise report directly to NEA before Completion Gateway (G3) and concluded before TOP could be granted.</li> </ul> <p><b>Who to submit:</b></p> <ul style="list-style-type: none"> <li>QP appointed should submit the above information and keep other relevant QPs in the loop.</li> <li>The same QP should follow through the submissions for all gateways.</li> </ul>
	<p> <b>Pollution Control Equipment (PCE)</b></p> <p>PCE submission will be required for developments involving proposed PCE/fuel burning equipment (e.g. Boiler, Thermal Oxidiser, Scrubber, Dust Collector, Spray Paint Booth, etc.)</p> <p><b>When to apply:</b></p> <ul style="list-style-type: none"> <li>Applicant will need to submit technical details of the PCE and/or Fuel Burning Equipment to NEA directly before Completion Gateway (G3) and concluded before TOP could be granted.</li> </ul> <p><b>Who to submit:</b></p> <ul style="list-style-type: none"> <li>QP appointed should submit the above information and keep other relevant QPs in the loop.</li> <li>The same QP should follow through the submissions for all gateways.</li> </ul>

Impact Studies / Site Layout, Rail Protection, Road Structure Protection	
Agency	Requirement Category
LTA	<p><b>Approval to commence engineering works within Railway Protection Zone / Railway Corridor</b></p> <ul style="list-style-type: none"> <li>To submit plan for engineering works</li> <li>To submit the Engineering evaluation report</li> <li>To submit an Instrumentation Proposal and initial instrumentation readings</li> <li>To submit a Method Statement of work</li> <li>To submit a Hazard Analysis identifying all possible risks that may be posed to the rapid transit system and a description of the safety and precautionary measures to mitigate these risks</li> <li>To submit the Contingency Plan and Emergency Procedure</li> <li>To submit the Pre-condition Survey Report</li> <li>To submit the Certified Survey Plans</li> <li>To submit the Permit application form and other relevant forms</li> <li>To submit the Construction schedule for the proposed development</li> </ul>



# Independent Agency Submissions

Legend:  Architecture  C&S  M&E IFC COMPONENT

Impact Studies / Site Layout, Rail Protection, Road Structure Protection <i>(continued from previous page)</i>	
Agency	Requirement Category
LTA <i>(continued from previous page)</i>	<p>Note: Refer to LTA's Code of Practice for Railway Protection / Guidebook for Carrying Out Modification Work to Rapid Transit System (RTS) Stations or Railway by Private Developer / Guide to carrying out restricted activities within railway protection and safety zones for more requirements / detailed description</p> <p><b><u>Approval to carry out restricted activities within Railway Safety Zone</u></b></p> <p>Note: Refer to LTA's Guide to carrying out restricted activities within railway protection and safety zones for detailed requirements / description</p> <p><b><u>Approval to commence engineering works within Road Structure Safety Zone / Notification to carry out engineering activity on land adjoining public street</u></b></p> <ul style="list-style-type: none"> <li>To submit plan for engineering works</li> <li>To submit the Engineering evaluation report</li> <li>To submit an Instrumentation Proposal and initial instrumentation readings</li> <li>To submit a Method Statement of work</li> <li>To submit a Hazard Analysis identifying all possible risks that may be posed to the rapid transit system and a description of the safety and precautionary measures to mitigate these risks</li> <li>To submit the Contingency Plan and Emergency Procedure</li> <li>To submit the Pre-condition Survey Report</li> <li>To submit the Certified Survey Plans</li> <li>To submit the Permit application form and other relevant forms</li> <li>To submit the Construction schedule for the proposed development</li> </ul> <p>Note: Refer to LTA's Guide to Carrying Out Engineering Works within Road Structure Safety Zone and Engineering Activity on Land adjoining Public Streets for more requirements/ detailed description</p>

Land / Strata Subdivision and Amalgamation	
Agency	Requirement Category
URA	<p><b><u>Land/Strata Subdivision and Amalgamation</u></b></p> <ul style="list-style-type: none"> <li>Proposed Subdivision and/or Amalgamation plan(s) / model by Registered Surveyor</li> </ul>

Mechanical Ventilation & Smoke Control System	
Agency	Requirement Category
SCDF	<p><b><u>Air-Conditioning, Mechanical Ventilation and Fire Protection Plan (MV &amp; FP)</u></b></p> <ul style="list-style-type: none"> <li>Automatic Fire Alarm System</li> <li>Automatic Fire Extinguishing System</li> <li>Emergency Voice Communication System</li> <li>Smoke Control System</li> <li>Calculations and reports (where applicable)</li> </ul>



# Independent Agency Submissions

Legend:  Architecture  C&S  M&E IFC COMPONENT

**Mechanical Ventilation & Smoke Control System** *(continued from previous page)*

Agency	Requirement Category
SCDF  <i>(continued from previous page)</i>	<p><b><u>Air-Conditioning, Mechanical Ventilation and Fire Protection Plan (MV &amp; FP)</u></b></p> <ul style="list-style-type: none"> <li>Detailed layout and floor plan showing Fire Protection and Mechanical Ventilation system of development</li> <li>Key features of the building in which the system is to be installed</li> <li>Schematic diagram of the overall system showing clearly the key features and their functions, relative locations in the building, lots, sizes, capacities and other essential information incl. the air distribution design arrangement in the case of air-conditioning and mechanical ventilation systems</li> <li>Layout of the system on every floor plan showing clearly the various parts and their functions, locations, arrangements, sizes, capacities and other essential information</li> <li>Necessary cross-sectional views as superimposed on the building or part thereof to fully describe the details and configurations of the system</li> <li>A colour scheme to clearly distinguish the various distinct parts of the system and the different systems from one another</li> <li>Volumetric rate of flow of air at each point of inlet and outlet of each system including those serving protected staircases, exit passageways, lobbies, areas of refuge, the Fire Command Centre, fire pump rooms, generator rooms, rooms used for the storage of flammable liquids or gas or other areas of special risk;</li> <li>Location of:                             <ul style="list-style-type: none"> <li>Fire compartment walls, floors, air shafts, fire dampers, smoke detectors and other fire precautionary features</li> </ul> </li> </ul> <p><b><u>Mechanical Ventilation System</u></b>                      QP to declare at those functional space which are provided with the following Ventilation System(s):</p> <ul style="list-style-type: none"> <li>Natural ventilation (NV)</li> <li>Mechanical ventilation (MV)*</li> <li>Pressurisation*</li> <li>Cross-ventilation</li> <li>Cross-ventilation with intermediate - ventilation opening</li> <li>Vapour extraction system (spray painting booth)</li> </ul> <p>*: Details to be provided and submitted by M&amp;E QP in Mechanical Ventilation (MV) Plan under Independent Submissions</p>

**Public Drains (External)**

Agency	Requirement Category
PUB	<ul style="list-style-type: none"> <li>Earth Control Measures (ECM) Plan</li> <li>Details of temporary works affecting drainage / within drainage reserve</li> </ul>

**Public Sewerage System (External)**

Agency	Requirement Category
PUB	<ul style="list-style-type: none"> <li>Details and scope of works on manholes and sewers</li> <li>Specified activities within sewer corridor</li> </ul>



# Independent Agency Submissions

Legend:  Architecture  C&S  M&E IFC COMPONENT

Public Transit Shelter (PS/TS)	
Agency	Requirement Category
<div style="background-color: green; height: 100px; width: 100%;"></div> <div style="background-color: yellow; height: 300px; width: 100%;"></div> <div style="background-color: orange; height: 30px; width: 100%;"></div> <div style="background-color: green; height: 30px; width: 100%;"></div> <div style="background-color: yellow; height: 30px; width: 100%;"></div>	<p><b>BCA</b></p> <p><b><u>Detailed CD Door and Services Penetration</u></b></p> <p>The following shall be clearly illustrated in the submission:</p> <ul style="list-style-type: none"> <li>○ EHD and PT door details - All CD door leaf and door frame details including frame anchorages and associated reinforcement. CD support structures and their line load reinforcement details, including any adjacent services penetrations.</li> <li>○ Services penetrations - Size of openings and type of services penetrations such as MCTs, puddle flanges etc in walls or slabs next to or in the vicinity of the CD doors.</li> </ul>
	<p><b><u>Mechanical Plans (CM)</u></b></p> <ul style="list-style-type: none"> <li>• <b>Environmental Control System (ECS), Water Supply System, Sanitary System, Drainage System, Fire Protection System</b></li> </ul> <p>The following shall be clearly illustrated in the submission for each of the systems above:</p> <ul style="list-style-type: none"> <li>○ All CD related plantrooms and ancillary rooms, locations, setting-out and performance capacities of CD related equipment, services sizes, layout and routings and their supports</li> <li>○ CD permanent toilets and CD dry toilets</li> <li>○ All CD related schematics, single line diagrams and typical installation details</li> <li>○ Locations, clear dimensions and performance capacities of CD related equipment, accessories, services and their supports from ceilings, walls and floors</li> <li>○ Size of openings and type of services penetrations such as MCTs, puddle flanges etc in walls or slabs next to or in the vicinity of the CD doors</li> <li>○ Provision of ventilation duct hinged-end doors (VDHD) at all ventilation supply and exhaust openings at the ventilation shafts/plenums</li> </ul>
	<p><b><u>Electrical Plan (CE)</u></b></p> <ul style="list-style-type: none"> <li>• <b>Electrical Power System, CD Communications System, CD Door Monitoring System, CD Equipment Monitoring System</b></li> </ul> <p>The following shall be clearly illustrated in the submission for each of the systems above:</p> <ul style="list-style-type: none"> <li>○ CD Plans layout at ground level, station concourse, station platform and any other level or space associated with the CD shelter, such as mezzanine floors and subway connections</li> <li>○ All CD related plantrooms and ancillary rooms, setting-out and performance capacities of CD related equipment, accessories and services sizes, layout, and routings and their related supports</li> <li>○ All CD related single line diagrams, schematics and typical installation details</li> <li>○ Locations, clear dimensions and performance capacities of CD related equipment, accessories, services and their supports from ceilings, walls and floors</li> <li>○ Size of openings and type of services penetrations such as MCTs, puddle flanges etc in walls or slabs next to or in the vicinity of the CD doors</li> </ul>
	<p><b><u>Shock Design</u></b></p> <p>Shock Design for Architectural &amp; Structural (CKS), Mechanical (CKM) and Electrical (CKE) works shall be submitted with the following:</p> <ol style="list-style-type: none"> <li>1. Cover letter</li> <li>2. Shock design report</li> <li>3. Shock calculations for equipment</li> <li>4. Shock calculations for services</li> <li>5. Detailed drawings for shock support</li> </ol>



# Independent Agency Submissions

Legend:  Architecture  C&S  M&E IFC COMPONENT

Signage	
Agency	Requirement Category
BCA	<ul style="list-style-type: none"> <li>License for Outdoor Advertising Sign or Signboard</li> </ul>

Structural Design	
Agency	Requirement Category
BCA	<p><b><u>Structural Design (Other Works e.g. demolition, ERSS, cladding, safety barrier, temporary traffic decking)</u></b></p> <ul style="list-style-type: none"> <li><b>2D Drawings are acceptable</b> for independent submissions.</li> <li>Structural design of ancillary works and component such as demolition, temporary ERSS, barriers &amp; cladding, temporary traffic decking</li> <li>Structural design of localized works for ancillary structures e.g. cladding, barrier</li> <li>These plans will need to make reference back to the coordinated model submitted by the Main QP at the Construction Gateway (G2).</li> </ul> <p> <b>Design Calculation Reports</b></p> <ul style="list-style-type: none"> <li>From QP, AC, [QP(Geo) &amp; AC (Geo), if needed]</li> </ul> <p> <b>Additional Supporting Documents:</b></p> <ol style="list-style-type: none"> <li>Site investigation report in pdf &amp; AGS format</li> <li>Impact assessment report</li> <li>Design consideration for Earth Retaining or Stabilising Structures (ERSS) – ERSS_Annex A</li> <li>QP’s &amp; AC’s Certification for fixings of ancillary structures</li> </ol>

Water Supply	
Agency	Requirement Category
PUB	<ul style="list-style-type: none"> <li>Site plans, water reticulation schematic / layout drawing of WSI design works and water requirements</li> <li>Specified activities within water pipe corridor</li> </ul>

----- **End of Requirements for Independent Agency Submissions** -----



## Completion (TOP/CSC) Gateway

Agency	Summary of Completion Gateway Requirements	
	TOP	CSC
<b>BCA</b>	<ul style="list-style-type: none"> <li>• Completion of structural works</li> <li>• Notice of Completion</li> <li>• Test records (if applicable)</li> <li>• Household / Storey Shelter commissioning</li> <li>• Site inspection (if applicable)</li> <li>• Technical agencies' clearance</li> </ul>	<p>Technical agencies' clearances</p>
<b>LTA</b>	NIL	<ul style="list-style-type: none"> <li>• Declaration that completed works have been supervised and built according to the approved street plans</li> <li>• Site inspection (if necessary)</li> <li>• As-built topographic survey plans</li> </ul> <p><b>Railway protection details:</b></p> <ul style="list-style-type: none"> <li>• Endorsed as-built plans for foundation, structural, M&amp;E (where applicable)</li> <li>• Building plans/details</li> <li>• Certificates of supervision</li> <li>• Final condition survey with reports</li> </ul> <p><b>For handing over:</b></p> <ul style="list-style-type: none"> <li>• Road data form</li> <li>• Asset master input form</li> <li>• Road test reports</li> <li>• Declaration plan</li> <li>• As-built M&amp;E plans</li> <li>• O&amp;T</li> </ul>
<b>NEA</b>	<ul style="list-style-type: none"> <li>• Photo evidence to demonstrate compliance in Design and Construction Gateways</li> <li>• Reports of completed works</li> <li>• Site inspection for selected projects and noise assessment report (ACMV) / Noise Impact assessment</li> </ul>	
<b>NParks</b>	NIL	<ul style="list-style-type: none"> <li>• As-built plan</li> <li>• Photo evidence to demonstrate compliance with NParks' requirements/approved submission(s) at preceding Gateway(s)</li> <li>• Site inspections (if applicable) – may involve soil check to ensure quality of planting mixture conforms to NParks' specifications for Approved Soil Mixture (ASM)</li> </ul>



## Completion (TOP/CSC) Gateway

Agency	Summary of Completion Gateway Requirements	
	TOP	CSC
<b>PUB</b>	<ul style="list-style-type: none"> <li>Declaration that completed works have been supervised and built according to approved plans</li> <li>Application for Compliance Certificate for Sanitary/Sewerage and TOP clearance for Drainage</li> <li>Site inspections (if necessary)</li> </ul> <p><b>To provide the following:</b></p> <ul style="list-style-type: none"> <li>As-built plans/survey plans/schematic sanitary drawing</li> <li>Form B1 clearance</li> <li>Relevant reports where applicable (hydrostatic test reports for sewer/sanitary, RC Trench reports, Pre DLP CCTV/Post-construction sewer CCTV survey report, air test report for sanitary plumbing system, design calculations etc)</li> </ul>	<p>For handing over of drainage or sewerage works for PUB’s maintenance, works to be satisfactorily completed and taken over by PUB prior to clearance:</p> <ul style="list-style-type: none"> <li>Taking over letter (issued by PUB)</li> </ul> <p><b>To provide the following:</b></p> <ul style="list-style-type: none"> <li>As-built plans/survey plans/schematic sanitary drawing</li> <li>Form B1 clearance</li> <li>PE endorsed handing over form for completed public drains</li> <li>Common drain assessment report</li> </ul>
<b>SCDF</b>	Temporary Fire Permit (TFP) application	Fire Safety Certificate (FSC) application
<b>URA</b>	<p><b>To provide the following:</b></p> <ul style="list-style-type: none"> <li>Declaration that completed works have been supervised and built in accordance to approved plans</li> <li>As-built plan incorporating approved amendments and as-built works that QPs declared to not have material impact to planning controls</li> <li>Photographs and/or inspections (where requested / necessary)</li> </ul>	

### ► Application for Completion of Works

A set of TOP / CSC checklists pertaining to agencies’ requirements will be provided to guide the project teams on the list of requirements for TOP / CSC applications. This includes as-built plan submissions, record plans, certificate of supervision, post-construction reports e.g. hydrostatic tests, RC trench report etc.

### ► Site Inspections

Similar to today’s practice, inspections would be carried out separately by agencies. Once agencies are notified on the project’s readiness for TOP / CSC, agencies will inform the project team if an audit/inspection is required. This is to help project teams plan / prepare their site early.

### ► TOP/CSC application

The status of each agencies’ TOP / CSC would be tracked through CORENET X where the overall TOP / CSC by BCA will only be released when all agencies’ respective clearances are obtained.

See also:  
[Latest CORENET X Circulars](#)



# Section 3: Specific Requirements by Key Gateways

## Completion (TOP/CSC) Gateway

INTRODUCTION TO CX

GENERAL REQUIREMENTS

REGULATORY AGENCIES

**KEY GATEWAYS**

OTHER BUILDING WORKS

BIM DATA REPRESENTATION



## Completion (TOP/CSC) Gateway

Legend: ■ Architecture ■ C&S ■ M&E  Builder IFC COMPONENT

BCA	
Item for TOP / CSC	Brief Description
<div style="display: flex; flex-direction: column; align-items: center;"> <div style="width: 15px; height: 15px; background-color: orange; margin-bottom: 5px;"></div> <div style="width: 15px; height: 15px; background-color: green; margin-bottom: 5px;"></div> <div style="width: 15px; height: 15px; background-color: yellow; margin-bottom: 5px;"></div> <div style="width: 15px; height: 15px; background-color: white; margin-bottom: 5px;"></div> </div>	<p><b>Buildability Design Implementation Plan (BDIP)</b></p> <ul style="list-style-type: none"> <li>BIM model which describes and defines the type, extent of use and details of the Design for Manufacturing (DfMA) technologies, building systems, building components, buildable features, design standardisation across the Structural, Architectural and Mechanical, Electrical and Plumbing (MEP) systems</li> <li>Where any of the above cannot be modelled in BIM, 2D plans can be submitted</li> </ul> <p> <b>Buildable Design Score (B-Score)</b></p> <p>a) BS03 Form (in Excel format) to be submitted</p> <hr/> <p><b>Constructability Implementation Plan (CIP)</b></p> <ul style="list-style-type: none"> <li>BIM Plans which describe and define the type, extent of use and details of the system framework</li> <li>Where any of the above cannot be modelled in BIM, 2D plans can be submitted</li> </ul> <p> <b>Supporting Documents for CIP:</b></p> <p>a) Documents (e.g. photos, 2D plans, etc.) on the use of construction techniques, processes, plant, equipment and innovative methods</p> <p> <b>Constructability Score (C-Score)</b></p> <p>a) C-Score Calculations (to be computed and submitted by Builder in PDF format)</p>
<div style="display: flex; flex-direction: column; align-items: center;"> <div style="width: 15px; height: 15px; background-color: orange; margin-bottom: 5px;"></div> <div style="width: 15px; height: 15px; background-color: green; margin-bottom: 5px;"></div> </div>	<p><b>Civil Defence Shelter (Non-Transit/Non-Public)</b></p> <ul style="list-style-type: none"> <li>Inspection of Civil Defence Shelter (Non-Transit/Non-Public)</li> <li>Checklist for submission with Inspection of Civil Defence Shelter (Non-Transit/Non-Public)</li> </ul>
<div style="display: flex; flex-direction: column; align-items: center;"> <div style="width: 15px; height: 15px; background-color: green; margin-bottom: 5px;"></div> </div>	<p><b>Completion of Structural Works</b></p> <ul style="list-style-type: none"> <li>Submission Certificate of Record Structural Plans/Calculations</li> <li>Certificate of Supervision of Piling/Structural Works</li> <li>Certificate of Supervision of Geotechnical Building Works</li> <li>Accredited Checker's Endorsement of Record Structural Plans/Calculation</li> <li>Specialist Accredited Checker's Endorsement of Record Geotechnical Building Works Plans/Calculation</li> <li>Builder certificate of completion of the Building Works</li> </ul>
<div style="display: flex; flex-direction: column; align-items: center;"> <div style="width: 15px; height: 15px; background-color: orange; margin-bottom: 5px;"></div> <div style="width: 15px; height: 15px; background-color: yellow; margin-bottom: 5px;"></div> </div>	<p><b>For Code for Environmental Sustainability of Buildings:</b></p> <p><u>To submit the following:</u></p> <ol style="list-style-type: none"> <li>BC ES Appendix 1 for <b>Completion Gateway</b> <a href="https://go.gov.sg/bc-es-app1">https://go.gov.sg/bc-es-app1</a></li> <li>Documentary Evidence based on the Guidance Notes and Documentation Requirements under Code for Environmental Sustainability of Buildings: <a href="https://www1.bca.gov.sg/buildsg/sustainability/regulatory-requirements-for-new-buildings-existing-buildings-undergoing-major-aanda">https://www1.bca.gov.sg/buildsg/sustainability/regulatory-requirements-for-new-buildings-existing-buildings-undergoing-major-aanda</a></li> </ol> <p><b>For Government Land Sales (GLS) programme requirement:</b></p> <p>Please refer to the following link: <a href="https://www1.bca.gov.sg/buildsg/sustainability/regulatory-requirements-for-new-buildings-existing-buildings-undergoing-major-aanda/mandatory-higher-green-mark-standard">https://www1.bca.gov.sg/buildsg/sustainability/regulatory-requirements-for-new-buildings-existing-buildings-undergoing-major-aanda/mandatory-higher-green-mark-standard</a></p>
<div style="display: flex; flex-direction: column; align-items: center;"> <div style="width: 15px; height: 15px; background-color: white; margin-bottom: 5px;"></div> </div>	<p><b>Façade</b></p> <ul style="list-style-type: none"> <li>Submit the Certificate of Completion of works (i.e. Form D, Form SB)</li> <li>For more information, please refer to: <a href="#">Industry requirement for installation, retrofitting, replacement or reinstatement of Windows   Building and Construction Authority (BCA)</a></li> </ul>

# Section 3: Specific Requirements by Key Gateways

## Completion (TOP/CSC) Gateway

INTRODUCTION TO CX

GENERAL REQUIREMENTS

REGULATORY AGENCIES

**KEY GATEWAYS**

OTHER BUILDING WORKS

BIM DATA REPRESENTATION



## Completion (TOP/CSC) Gateway

Legend:



Architecture



C&S



M&E



Builder

IFC COMPONENT

BCA						
Item for TOP / CSC	Brief Description					
Public/Transit Shelter (PS/TS) Technical Clearances	<p><b>Method statement for commissioning tests (CT)</b></p> <ol style="list-style-type: none"> <li>Internal overpressure test (IOPT)</li> <li>Overpressure regime and airflow test (ORAT)</li> <li>Integration system test (IST)</li> </ol>					
	<p><b>Commissioning test report (CT)</b></p> <ol style="list-style-type: none"> <li>Internal overpressure test (IOPT)</li> <li>Overpressure regime and airflow test (ORAT)</li> <li>Integration system test (IST)</li> </ol>					
	<p><b>Notice of Approval of Commissioning (NOAC) (CN)</b></p> <table border="1"> <tr> <td> <ol style="list-style-type: none"> <li>CD NOA letters of As-built plans for:                             <ul style="list-style-type: none"> <li>Architectural</li> <li>Structural</li> <li>ECS</li> <li>FPS</li> <li>Water Services</li> <li>Sanitary</li> <li>Drainage</li> <li>Electrical</li> <li>CD Communications</li> <li>CD EMS System</li> <li>CD Door Monitoring System</li> <li>CD MATV</li> </ul> </li> </ol> </td> <td> <ol style="list-style-type: none"> <li>CD Certificate of Supervision (COS) letters for:                             <ul style="list-style-type: none"> <li>CD Related Architectural Works</li> <li>CD Related Structural Works, MCTs, CD Valves, CD Doors</li> <li>CD Electrical System</li> <li>CD Door Monitoring System</li> <li>CD Equipment Monitoring System</li> <li>CD Communications System</li> <li>CD Environment Control System &amp; Fire Protection Systems</li> <li>CD WSSDS</li> </ul> </li> </ol> </td> <td> <ol style="list-style-type: none"> <li>CD NOA letters for IOPT, ORAT and CDIST reports</li> </ol> </td> <td> <ol style="list-style-type: none"> <li>CD NOA letters with summary table for all shock design submissions</li> </ol> </td> <td> <ol style="list-style-type: none"> <li>CD NOAC Inspection Report with rectified defects list containing clear before and after colour photos and description of remedial actions taken.</li> </ol> </td> </tr> </table>	<ol style="list-style-type: none"> <li>CD NOA letters of As-built plans for:                             <ul style="list-style-type: none"> <li>Architectural</li> <li>Structural</li> <li>ECS</li> <li>FPS</li> <li>Water Services</li> <li>Sanitary</li> <li>Drainage</li> <li>Electrical</li> <li>CD Communications</li> <li>CD EMS System</li> <li>CD Door Monitoring System</li> <li>CD MATV</li> </ul> </li> </ol>	<ol style="list-style-type: none"> <li>CD Certificate of Supervision (COS) letters for:                             <ul style="list-style-type: none"> <li>CD Related Architectural Works</li> <li>CD Related Structural Works, MCTs, CD Valves, CD Doors</li> <li>CD Electrical System</li> <li>CD Door Monitoring System</li> <li>CD Equipment Monitoring System</li> <li>CD Communications System</li> <li>CD Environment Control System &amp; Fire Protection Systems</li> <li>CD WSSDS</li> </ul> </li> </ol>	<ol style="list-style-type: none"> <li>CD NOA letters for IOPT, ORAT and CDIST reports</li> </ol>	<ol style="list-style-type: none"> <li>CD NOA letters with summary table for all shock design submissions</li> </ol>	<ol style="list-style-type: none"> <li>CD NOAC Inspection Report with rectified defects list containing clear before and after colour photos and description of remedial actions taken.</li> </ol>
	<ol style="list-style-type: none"> <li>CD NOA letters of As-built plans for:                             <ul style="list-style-type: none"> <li>Architectural</li> <li>Structural</li> <li>ECS</li> <li>FPS</li> <li>Water Services</li> <li>Sanitary</li> <li>Drainage</li> <li>Electrical</li> <li>CD Communications</li> <li>CD EMS System</li> <li>CD Door Monitoring System</li> <li>CD MATV</li> </ul> </li> </ol>	<ol style="list-style-type: none"> <li>CD Certificate of Supervision (COS) letters for:                             <ul style="list-style-type: none"> <li>CD Related Architectural Works</li> <li>CD Related Structural Works, MCTs, CD Valves, CD Doors</li> <li>CD Electrical System</li> <li>CD Door Monitoring System</li> <li>CD Equipment Monitoring System</li> <li>CD Communications System</li> <li>CD Environment Control System &amp; Fire Protection Systems</li> <li>CD WSSDS</li> </ul> </li> </ol>	<ol style="list-style-type: none"> <li>CD NOA letters for IOPT, ORAT and CDIST reports</li> </ol>	<ol style="list-style-type: none"> <li>CD NOA letters with summary table for all shock design submissions</li> </ol>	<ol style="list-style-type: none"> <li>CD NOAC Inspection Report with rectified defects list containing clear before and after colour photos and description of remedial actions taken.</li> </ol>	
Record Building Plans	<ul style="list-style-type: none"> <li>Record Plans</li> </ul>					
Technical Clearance (TOP/CSC)	<ul style="list-style-type: none"> <li>Universal Design Index FormSG Acknowledgement</li> <li>CONQUAS / QM</li> <li>Waiver Approval</li> </ul>					
	<ul style="list-style-type: none"> <li>Site Inspection Report/Checklist</li> <li>Phasing Plan</li> <li>Clearance for Environmental Sustainability</li> <li>Clearance for Buildability and Constructability</li> </ul>					
	<ul style="list-style-type: none"> <li>Annex A Safety Barrier</li> <li>Annex A Engineered Façade</li> </ul>					
	<ul style="list-style-type: none"> <li>Certificate of Supervision for Lightning Protection System (LPS)</li> <li>Permit to Operate (Lift &amp; Escalator)</li> <li>Certificate of Supervision for Air-Conditioning and Mechanical Ventilation System(s)</li> </ul>					
	<ul style="list-style-type: none"> <li>Builder's Certificate (for building works without any structural works)</li> </ul>					



# Completion (TOP/CSC) Gateway

Legend:  Architecture  C&S  M&E IFC COMPONENT

LTA	
Item for TOP / CSC	Brief Description
-	<p><b><u>Application for clearance of certificate of statutory completion for development within Railway Protection Zone / Railway Corridor</u></b></p> <ul style="list-style-type: none"> <li>To submit a copy as-built topographic survey plan in true coordinates</li> <li>To submit a certificate of supervision</li> <li>To submit the final condition survey report</li> </ul>
	<p><b><u>For proposed developments which involve modification to RTS, development to comply with <i>Guidebook for Carrying Out Modification Work to Rapid Transit System (RTS) Stations</i></u></b></p> <p>Note: Refer to LTA's Code of Practice for Railway Protection / Guidebook for Carrying Out Modification Work to Rapid Transit System (RTS) Stations or Railway by Private Developer for more requirements / detailed description</p>
	<p><b><u>For developments that involve only the widening and alteration of existing street fronting the development (without new street), the following shall be submitted:-</u></b></p> <ul style="list-style-type: none"> <li>As-built topographic survey plan in true coordinates</li> <li>To submit an approved subdivision plan with WP from URA and Certified Plan (CP) for project with vesting of street reserve plot</li> <li>Photographs of completed works</li> </ul>
	<p><b><u>For Notification of Opening of New Street to Traffic, the following shall be submitted:</u></b></p> <ul style="list-style-type: none"> <li>Cover letter clearly stating the new street opening date.</li> <li>Street and Building Name Board (SBNB) Approval letter of street name</li> <li>Approved traffic layout plan</li> <li>Certificate of Supervisions by PE</li> <li>Road Test Result</li> <li>Checklist of completed works</li> <li>Photographs of completed works</li> </ul>
	<p><b><u>For handing over of new road, the following shall be submitted:</u></b></p> <ul style="list-style-type: none"> <li>As-built topographic survey plan in true coordinates (in .dwg format)</li> <li>As-built structural and M&amp;E plans for commuter facilities such as POB, UPN</li> <li>Taking over letters from PUB, NParks and NEA</li> <li>Road Declaration Plan</li> <li>Approved sub-division plan</li> <li>Certified plan from Chief Surveyor, SLA</li> <li>Asset Master Record Input Form</li> <li>Road Data Form</li> <li>Audit certificate for project under Ministries or Statutory Board</li> <li>Road testing results</li> <li>Documents for handing over of street lightings - as-built installation plans, electrical single line diagram, letter of supervisions, test report from SP services for new control box and underground cable insulation resistance test report</li> <li>Warranties for waterproofing etc.</li> </ul>
	<p><b><u>For Vehicle Parking submission:</u></b></p> <ul style="list-style-type: none"> <li>Photos for open surface parking lots</li> <li>As built Drawings</li> </ul>

## Section 3: Specific Requirements by Key Gateways

### Completion (TOP/CSC) Gateway

INTRODUCTION TO CX

GENERAL REQUIREMENTS

REGULATORY AGENCIES

**KEY GATEWAYS**

OTHER BUILDING WORKS

BIM DATA REPRESENTATION

G3

## Completion (TOP/CSC) Gateway

Legend:



Architecture





C&S











M&E

IFC COMPONENT

NEA		
	Item for TOP / CSC	Brief Description
 	Photo, video or reports of completed works	<ul style="list-style-type: none"> <li>QP (Arch/PEs) applies for TOP/CSC and provide photo / video evidence or reports of completed works</li> </ul>

NParks		
	Item for TOP / CSC	Brief Description
	TOP/CSC	<ul style="list-style-type: none"> <li>As-built plan</li> <li>Photo evidence to demonstrate compliance with NParks' requirements/approved submission(s) at preceding Gateway(s)</li> <li>Site inspections (if applicable) – may involve soil check to ensure quality of planting mixture conforms to NParks' specifications for Approved Soil Mixture (ASM)</li> </ul>

SCDF		
	Item for TOP / CSC	Brief Description
 	-	<p><b>QP(s) shall certify that the fire safety works have been completed in accordance with the Code of Practice for Fire Precautions in Buildings, Fire Safety Act and its Regulations and relevant Codes of Practice and submit the following documents:</b></p> <ul style="list-style-type: none"> <li>Certification of Fire Safety Works</li> <li>RI Engagement Form</li> <li>Registered Inspector's Inspection Certificate (RI Form 1 or 2)</li> <li>RI Inspection Report</li> <li>RI Cessation form, where applicable</li> <li>Declaration of Regulated Fire Safety Products, where applicable</li> <li>CoC for Regulated Fire Safety Products, where applicable</li> <li>Delivery Orders for Regulated Fire Safety Products, where applicable</li> <li>FSC02 - Certification for Regulated Fire Safety Products, where applicable</li> <li>FSC03 - Certification for Lift Installation &amp; Operation, where applicable</li> <li>FSC04 - Certification for Fire Engine Access Road And Accessway, where applicable</li> </ul>

URA		
	Item for TOP / CSC	Brief Description
 	Development Interface Report (DIR) (Final)	<ul style="list-style-type: none"> <li>Information for future developer (e.g. loading requirements, knock out panels alignment / width)</li> <li>As-built plan</li> </ul>
  	TOP / CSC	<ul style="list-style-type: none"> <li>Declaration that completed works have been supervised and built in accordance to approved plans (via EDAForm)</li> <li>Photographs of completed works or rectifications (where requested)</li> <li>Phasing Plan (for Partial TOP)</li> <li>Inspections (where necessary)</li> </ul>
	Record Plan (for non-conserved buildings and monuments)	<ul style="list-style-type: none"> <li>As-built plan incorporating approved amendments and as-built works that QPs declared to not have material impact to planning controls</li> </ul>



----- End of Requirements for Completion Gateway (G3) -----

# SECTION 3

Specific Requirements by:  
*Other Building Works*



## 3 Specific Requirements by

	<b>Page</b>
	
<b>Regulatory Agencies</b>	
• BCA	29
• LTA	40
• NEA	46
• NParks	56
• PUB	60
• SCDF	63
• URA	72
	
<b>Key Gateways</b>	
Overview	85
Glossary of Common Key Words	86
- Pre-Submission, Planning and Other Consultations	89
• <b>G1</b> Design Gateway	96
• <b>G1.5</b> Piling Gateway (Optional)	113
• <b>G2</b> Construction Gateway	116
- Independent Submissions	143
• <b>G3</b> Completion Gateway (TOP/CSC)	151
	
<b>Other Building Works</b>	
• Overview of External Works	159
○ LTA	161
○ NParks	171
○ PUB	174
• Direct Submission Process (DSP)	178
• Conservation	179
• Part ST Submission	181
• Infrastructure Works	186



# External Works



## About

Note that External Works is undergoing further refinements. More updates will be released in future COP versions.

- Under CORENET X, the QP has to submit the proposed external works to the LTA, NParks and PUB for a coordinated regulatory review. To guide the industry in preparing their external works submissions at the various gateways, the agencies have worked together to map their regulatory objectives and requirements. Due care was taken to ensure that:
  - ✓ There are no direct conflicts in the rules between the agencies.
  - ✓ Various components of the road typology is holistically reviewed by the respective agencies within the same gateway.

External works details can be submitted in the 2D CAD format.

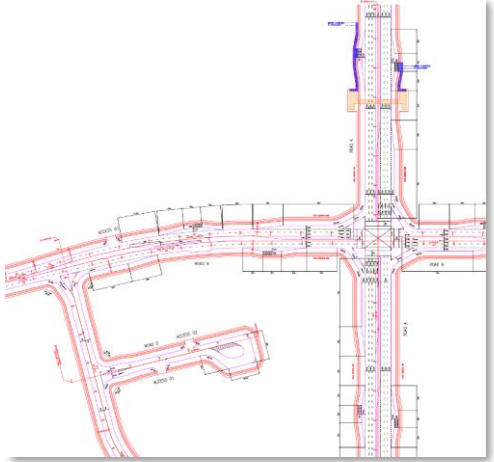
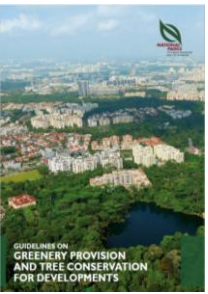
## Sharing of Submission Templates to Standardise Details

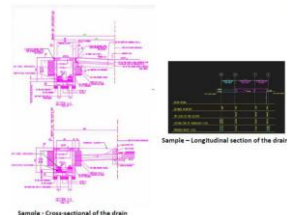
Agency	2D Plan Representation / Templates	Examples																								
	Description	Examples																								
<p><b>LTA</b></p>	<ul style="list-style-type: none"> <li>LTA will provide drawing templates for the various plans (e.g. traffic, alignment, site plan, profile, section / details etc.) to better guide QPs to prepare the design details to be reflected in the plans.</li> <li>➤ Example, S3 – Fig 1 (right): Part of a road layout template for various common road infrastructure facilities.</li> </ul>																									
<p><b>NParks</b></p>	<ul style="list-style-type: none"> <li>QPs can refer to NParks’ handbook (see right S3 – Fig 2) for information to be provided to facilitate assessment and approval of development applications. See right S3 – Fig 2.</li> <li>➤ <a href="#">Guidelines on Greenery Provision and Tree Conservation for Developments</a></li> </ul>	 <table border="1" data-bbox="1101 1500 1548 1792"> <thead> <tr> <th>Information to be Provided (See Information)</th> <th>Information to be Provided (See Information)</th> </tr> </thead> <tbody> <tr> <td>1. All boundary line to be marked and indicated in their respective colour. The boundary should be consistent with architectural plans (if applicable) throughout the project.</td> <td>1. Proposed Development layout</td> </tr> <tr> <td>2. Specific, girth and height of existing trees within the site boundary and on the neighbouring site (in 2D or 3D view) shall be indicated in a table.</td> <td>2. Development boundary outlined in red</td> </tr> <tr> <td>3. Existing tree-like trees (other public trees) within the development boundary shall be up to 100mm in girth (at the boundary) to be indicated.</td> <td>3. Existing and proposed road lines to be outlined in red</td> </tr> <tr> <td>Any changes to the status of the existing trees approved at DCP/DP stage of Architect's plan are to be indicated.</td> <td>4. Utility planning and proposed roads</td> </tr> <tr> <td>4. Colour code for existing trees/other trees:</td> <td>5. Category of existing and proposed roads</td> </tr> <tr> <td><b>Status of Existing Trees/Other Trees</b></td> <td><b>Outline in Colour</b></td> </tr> <tr> <td>To be retained</td> <td>Green</td> </tr> <tr> <td>To be retained</td> <td>Yellow</td> </tr> <tr> <td>Retained without approval</td> <td>Red</td> </tr> <tr> <td>Retained with written approval</td> <td>Yellow indicate the approved date in the tree schedule</td> </tr> <tr> <td>Non-scheduled other trees</td> <td>Indicate in 'Other' on tree schedule</td> </tr> </tbody> </table>	Information to be Provided (See Information)	Information to be Provided (See Information)	1. All boundary line to be marked and indicated in their respective colour. The boundary should be consistent with architectural plans (if applicable) throughout the project.	1. Proposed Development layout	2. Specific, girth and height of existing trees within the site boundary and on the neighbouring site (in 2D or 3D view) shall be indicated in a table.	2. Development boundary outlined in red	3. Existing tree-like trees (other public trees) within the development boundary shall be up to 100mm in girth (at the boundary) to be indicated.	3. Existing and proposed road lines to be outlined in red	Any changes to the status of the existing trees approved at DCP/DP stage of Architect's plan are to be indicated.	4. Utility planning and proposed roads	4. Colour code for existing trees/other trees:	5. Category of existing and proposed roads	<b>Status of Existing Trees/Other Trees</b>	<b>Outline in Colour</b>	To be retained	Green	To be retained	Yellow	Retained without approval	Red	Retained with written approval	Yellow indicate the approved date in the tree schedule	Non-scheduled other trees	Indicate in 'Other' on tree schedule
Information to be Provided (See Information)	Information to be Provided (See Information)																									
1. All boundary line to be marked and indicated in their respective colour. The boundary should be consistent with architectural plans (if applicable) throughout the project.	1. Proposed Development layout																									
2. Specific, girth and height of existing trees within the site boundary and on the neighbouring site (in 2D or 3D view) shall be indicated in a table.	2. Development boundary outlined in red																									
3. Existing tree-like trees (other public trees) within the development boundary shall be up to 100mm in girth (at the boundary) to be indicated.	3. Existing and proposed road lines to be outlined in red																									
Any changes to the status of the existing trees approved at DCP/DP stage of Architect's plan are to be indicated.	4. Utility planning and proposed roads																									
4. Colour code for existing trees/other trees:	5. Category of existing and proposed roads																									
<b>Status of Existing Trees/Other Trees</b>	<b>Outline in Colour</b>																									
To be retained	Green																									
To be retained	Yellow																									
Retained without approval	Red																									
Retained with written approval	Yellow indicate the approved date in the tree schedule																									
Non-scheduled other trees	Indicate in 'Other' on tree schedule																									
<p><b>PUB</b></p>	<ul style="list-style-type: none"> <li>PUB has published a series of quick guides (see right S3 – Fig 3) with sample illustrations which outline the necessary information to be provided by QPs in their submissions to facilitate assessment and clearances.</li> <li>➤ <a href="#">Quick Guide to Application for Clearance Certificate for Detailed Plan</a></li> </ul>	 																								



# External Works

## ► Delinking Clearance of Development (Internal) and External Works where feasible

Note: The submission format for proposed works within the development boundary shall follow the prevailing BIM submission requirements. Design proposals for external works can be submitted in 2D (CAD). Notwithstanding, agencies are open to reviewing infrastructure models prepared in 3D.

### Development (Internal) and External Works

Under CORENET X, LTA, NParks and PUB require:

- a) Proposed works within the development boundary; and
- b) Proposed external works to be submitted a single package across the regulatory gateways to ensure that both works are well coordinated. For example, for LTA:
  - i. Works within the development boundary pertain to:
    - Vehicle parking layout/ Bicycle parking lots
    - Layout of pick-up/ drop-off (PUDO) points
    - Internal driveways
    - EV charging infrastructure
  - ii. External works pertain to works within the road reserve, such as:
    - Street improvement works
    - Commuter facilities
    - Active mobility infrastructure



S3 - Fig 4 :  
Example of development (internal) work - PUDO layout



S3 - Fig 5:  
Example of external work - Road infra improvement

### Interfacing Aspects to be cleared as part of Development (Internal) Works

1. It is common for a development to propose connections (serving various users such as motorists, pedestrians, cyclist etc) from within the development leading to the surrounding road network. These connections form interfaces at the development boundary. Such interfaces have to be well coordinated to ensure that the development platform level ties in properly with the existing roads. For new roads proposed in conjunction with development(s), the vertical profile of the roads (designed to comply with LTA design requirements) has to be established before other development interfacing details are considered. Additionally, interfaces usually demarcate the extent of maintenance ownership between the developer and the State.
2. The layout and cross-sections of interfaces between the development boundary and the road reserve shall be clearly reflected in the external works design proposal.

S/N	LTA and NParks Interfacing Aspects
1	Vehicular Access Points
2	Pedestrian Access Points
3	Cyclist accesses
4	Covered Linkway / Walkway Connections
5	Pedestrian Overhead Bridge Connections
6	Pedestrian Underpass Connections
7	Bus Stops (If directly interfacing with the development building)
8	Taxi Stands (If directly interfacing with the development building)
9	Vertical Profile of New Street (If proposal involves construction of a new street or widening of existing roads)

S/N	PUB Interfacing Aspects
1	Connection of internal drain to road drain/ drain outlet
2	MPL, adj road/ ground level, and outlet discharge point levels
3	Point of proposed sewer connection



S3 - Fig 6





# LTA's Interfacing Aspects

## ► Interfacing Aspects to be cleared as part of Development (Internal) Works

LTA considers the following as interfacing aspects:

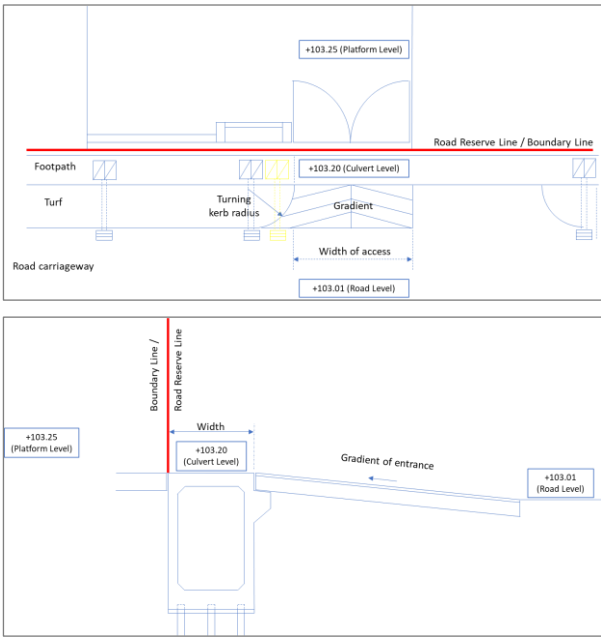
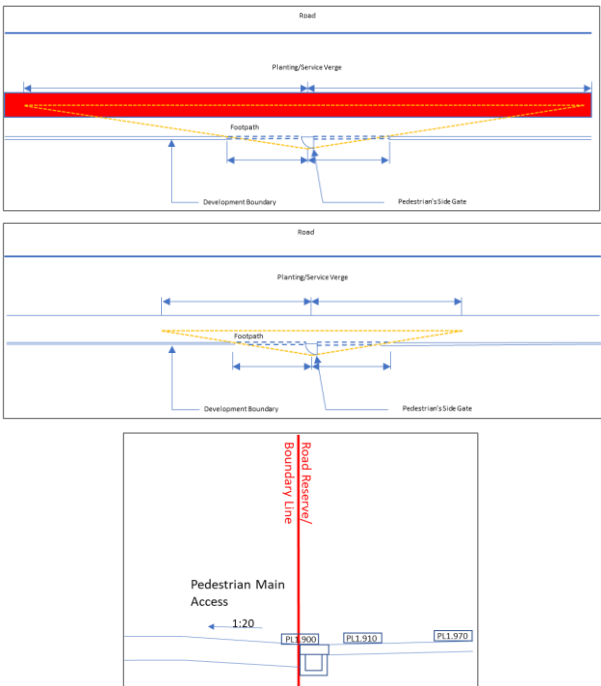
S/N	Interfacing Aspect	Remarks
1	<p><b>Vehicular Access Points</b></p> 	<p>Vehicular accesses have a significant impact on the development layout and has to be co-ordinated with the proposed Minimum Platform Level imposed.</p> <p>--</p> <p>S3 – Fig 7 (top): Plan view of an access                      S3 – Fig 8 (bottom): Cross Section view of an access</p>
2	<p><b>Pedestrian Access Points</b></p> 	<p>Pedestrian accesses have to be designed with respect to the internal layout and the external amenities of interest to development users</p> <p>--</p> <p>S3 – Fig 9 (top): Plan view of pedestrian access interfacing with footpath &amp; cycling path (with sight visibility triangle)</p> <p>S3 – Fig 10 (middle): Plan view of pedestrian access interfacing with a shared path (with sight visibility triangle)</p> <p>S3 – Fig 11 (bottom): Cross section of a pedestrian access interfacing with a footpath</p>



# LTA's Interfacing Aspects

## ► Interfacing Aspects to be cleared as part of Development (Internal) Works

LTA considers the following as interfacing aspects:

S/N	Interfacing Aspect	Remarks
3	Cyclist Accesses (Please refer to typical section and plan view in S/N 4.)	Cyclist accesses have to be designed with respect to internal bicycle parking facilities and the surrounding road network. One of the important design issues is the provision of adequate sight distance at the development accesses and inner radius of road bends.
4	<b>Covered Linkways</b> (At-grade connections between the development and road reserve) 	Covered linkways have to be designed with respect to the internal layout and the external amenities of interest to development users -- S3 – Fig 12 (left): Roof plan of a sheltered walkway interfacing with an existing covered linkway (within the road reserve) S3 – Fig 13 (right): Cross section of a sheltered walkway interfacing with an existing covered linkway (within the road reserve)
5	<b>Pedestrian Overhead Bridges (POBs)</b> (Elevated connections between the development and road reserve) 	Direct linkages between POBs and developments have to be designed to ensure that the levels of the POB and development can match -- S3 – Fig 14 (left): Plan view of an elevated walkway interfacing with an existing POB (within the road reserve) S3 – Fig 15 (right): Cross section of an elevated walkway interfacing with an existing POB (within the road reserve)
6	<b>Pedestrian Underpasses (PUPs)</b> (Subterranean connections between the development and road reserve)	Direct linkages between PUPS and developments have to be designed to ensure that the levels of the PUP and development can match
7	<b>Bus Stops</b> (If directly interfacing with the development)	Interfacing (if any) between bus stops and developments have to be co-ordinated



## LTA's Interfacing Aspects

### ► Interfacing Aspects to be cleared as part of Development (Internal) Works

LTA considers the following as interfacing aspects:

S/N	Interfacing Aspect	Remarks
8	<b>Taxi Stands</b> (If directly interfacing with the development)	Interfacing (if any) between taxi stands and Developments have to be co-ordinated
9	<b>Covered Walkways</b>	Covered walkways have to be designed in relation to the open walkways for barrier-free access
10	<b>Vertical Profile of New Street</b> (If the proposal involves the construction of a new street and / or widening of existing roads)	It is important to establish the vertical profile of the new street / widened street which determines all other interfacing aspects, such as development platform levels, drainage levels, access levels, as well as the levels of any existing structures (while complying to the current design requirements)

#### Clearances and Conditional Approvals

- LTA will issue a **Layout Plan Clearance (Street & Parking)** at the Design Gateway (G1), as well as a **Street Plan Clearance** and **Vehicle Parking Building Plan Clearance** at the Construction Gateway (G2), when both the proposed works within the development boundary and external works are designed in accordance with the prevailing standards.
- In a scenario where the proposed works within the development boundary are in order, whereas the external works are still under review, **LTA may issue separate Layout Plan and Street Plan Approvals**, for internal and external works. For LTA to issue a conditional approval, all interfacing aspects shown within the external works proposal must be designed in accordance with the prevailing standards.
- The approvals for internal works granted by LTA once the interfacing aspects have been agreed, will help to expedite the clearance and completion of the projects, notwithstanding the requirement for combined submission under CORENET X. QPs are required to follow up and **obtain the agencies' full external works clearances**, before advancing to the next regulatory gateway.

#### Example Scenario 1

QP submits external and internal works proposal

Both external, internal works (with interfacing details) are in order by 3<sup>rd</sup> submission

Agencies will issue the complete clearances for both internal and external works.  
 Specifically, LTA issues a complete street layout plan/ street plan clearance  
 (Project parties can proceed with construction / sales at CG (G2))

#### Example Scenario 2

QP submits external and internal works proposal

Internal works, but not external works are in order by 3<sup>rd</sup> submission

Agencies issue clearance for the internal works  
 (Project parties can proceed with construction / sales at CG(G2))

Agencies issue clearances for the external works



## Overview of LTA's External Works

Note that External Works is undergoing further refinements. More updates will be released in future COP versions.

Key Gateways	Objective	Road alignment details to be prepared (other details to be prepared and submitted as required)	Supporting Information required
<b>Pre-DG (Land Use, TCOT, PAFS, TIA)</b>	To establish RRL and development boundary	<ol style="list-style-type: none"> <li>1. Horizontal alignment</li> <li>2. Junction layout</li> <li>3. Commuter facilities</li> <li>4. Cycling path</li> <li>5. Road typology</li> <li>6. Development access</li> <li>7. RRL / ADR</li> </ol>	<ol style="list-style-type: none"> <li>1. Topo survey</li> <li>2. Traffic study / TIA</li> </ol>
<b>Pre-Submission, Planning and Other Consultations</b>	To seek clarifications for details to be submitted at DG stage	As required by Agency / QP to seek clarification from LTA	<ol style="list-style-type: none"> <li>1. Traffic study / TIA</li> </ol>
<b>Design Gateway (G1)</b>	To establish development platform level and development access that will properly interface with the proposed carriageway	<ol style="list-style-type: none"> <li>1. All details as per Pre-DG Stage</li> <li>2. Development access levels to tie in with development platform level *</li> <li>3. Road vertical profile * (applicable to new streets and widening of existing carriageways)</li> <li>4. Cross-section and details plan</li> <li>5. Tree affected plan.</li> <li>6. Layout of retaining wall.</li> <li>7. Extent of proposed cut / fill slopes with existing ground level including impact on existing trees</li> <li>8. Layout of drains, sumps and box culvert including drain top level and invert level</li> <li>9. Layout of major structural works that will affect the road vertical and horizontal alignment.</li> <li>10. Layout for Commuter Facilities (e.g. bus stop, covered linkways, POB) *</li> <li>11. Layout of Active Mobility Infrastructure (i.e. cycling path)</li> <li>12. Layout of street elements (e.g. lamppost, traffic schemes) that needs to be modified. (Applicable for existing streets)</li> </ol>	<ol style="list-style-type: none"> <li>1. Topo survey</li> <li>2. Utilities / services plan</li> </ol>
<b>Piling Gateway (G1.5) (Optional)</b>	Piling gateway also includes earth retaining structures (slope, retaining wall, CBP etc.) within the road reserve	-	-
<b>Construction Gateway (G2)</b>	To finalise all other details necessary for construction of the road and related infrastructure works	<ol style="list-style-type: none"> <li>1. All details as per DG stage</li> <li>2. Details for access points *</li> <li>3. Geotechnical details for foundation works, retaining wall, slope etc.</li> <li>4. Structural details for road structures and roadside features e.g. POB, drain, box culvert, sump etc.</li> <li>5. Architectural &amp; Engineering details for Commuter Facilities (structural and foundation details) *</li> </ol>	-
<b>Independent Submissions</b>	To finalise individual agency requirements after construction gateway that do not have any impact on other agencies requirements	Approval to commence engineering works/ restricted activities within the Railway Protection Zone	-

\* These aspects include (the necessary) interfacing works with the internal layout. Proposed interfacing works should be submitted as part of the external works design proposal and cleared in tandem with internal layout.



# LTA's External Works Requirements

Legend: ■ Architecture ■ C&S ■ M&E

<b>G1</b>	<b>Design Gateway</b>
<b>Objective:</b>	
✓ To establish development platform level and development access that will properly interface with the proposed carriageway	
✓ <b>Requirements for Road Infrastructure and Vehicle Access</b>	
	<p><b><u>Vehicular Access Points</u></b></p> <p><b><u>Connections and Interfaces at Development Boundary</u></b></p> <ul style="list-style-type: none"> <li>To indicate the road level, entrance culvert level, and the proposed development platform level.</li> <li>For new roads proposed in conjunction with development(s), to develop the development platform level and proposed levels of the development access points based on the vertical alignment of the proposed carriageway (before QP confirms on the development platform level for the design of the foundation / structural works).</li> <li>To show the gradient of entrance approach.</li> <li>To indicate the configuration of the proposed access.</li> <li>To indicate the width and turning radius of the proposed access.</li> <li>To indicate the provision of tactile tiles.</li> <li>To indicate any proposed relocation of existing road elements, such as trees, lamp post, signs etc, which may be affected by proposed access.</li> </ul>
	<p><b><u>Layout of Proposed Frontage Improvement Works</u></b></p> <ul style="list-style-type: none"> <li>To determine the extent of improvement works required along the road sidetable, such as conversion of open drain to covered drain cum footpath, setting back of drain for development affected by RRL</li> <li>To indicate the proposed footpath width, level, and its gradient</li> <li>To determine the extent of improvement works required along the road carriageway, such as localised road widening etc.</li> <li>To relocate any existing Manholes located on the future carriageway</li> <li>To check if additional street lightings are required</li> <li>To vest the Street Reserve Plot in State (except for A&amp;A proposal)</li> </ul>
	<p><b><u>Design of New Street (incl. Modifications to Existing Streets)</u></b></p> <ul style="list-style-type: none"> <li>To indicate all details determined during the planning consultation stage, and clearly list down the design changes from TCOT / land use stage.</li> <li>To identify and declare all non-compliances to design standards.</li> <li>To submit the road alignment and junction layout plan.</li> <li>To develop and submit the horizontal alignment and vertical profile of the proposed carriageway (new or widening / realignment of existing carriageway) connecting to the existing junction / carriageway. The horizontal alignment includes the superelevation along the road bends.</li> <li>To show the drainage layout plan (drain, box culvert and sump) and the drainage vertical profile, drain top level and invert level in the profile / longitudinal section drawing.</li> <li>To show the extent of cut / fill slopes with existing ground level and indicate the impact on existing trees (identify to trees to be fell, retained etc.).</li> <li>To show the location and layout of commuter facilities and major structural works that will affect the road vertical and horizontal alignment in the plan view, longitudinal section drawing and cross-section drawing.</li> <li>To show the extent of retaining wall to be provided (within or abutting the RRL) in the layout plan, and the layout and height of the retaining wall in the longitudinal section plan and cross-section drawings.</li> <li>To show the tree affected plan (trees to be fell, retained etc).</li> <li>To show cross-section details of the proposed typology of road sidetable and roadside features and structures (POB, linkway, bus-stop, drain, box-culvert etc.</li> <li>To relocate any existing Manholes located on the future carriageway.</li> <li>To seek waiver for retention of existing manhole on future road carriageway, cycling path and footpath, if any.</li> </ul>



# LTA's External Works Requirements

Legend: ■ Architecture ■ C&S ■ M&E

<b>G1</b>	<b>Design Gateway</b>
<b>Objective:</b>	
✓ To establish development platform level and development access that will properly interface with the proposed carriageway	
✓ <b>Requirements for Road Infrastructure and Vehicle Access</b>	
	<b>Connections and Interfaces at Development Boundary</b>
	<ul style="list-style-type: none"> <li>To develop the development platform level and proposed levels of the development access points based on the vertical alignment of the proposed carriageway (before developer confirms on the development platform level for the design of the foundation / structural works).</li> <li>To show the extent of retaining wall to be provided (within or abutting the RRL) in the layout plan, and the layout and height of the retaining wall in the longitudinal section plan and cross-section drawings.</li> </ul>
	✓ <b>Requirements for Commuter Facilities</b>
	<b>Layout of Covered Linkway / High Covered Linkway</b>
	<ul style="list-style-type: none"> <li>To show the proposed layout i.e. alignment, width, and headroom of the covered linkway / high covered linkway.</li> <li>To show the location where the covered linkway connects with the existing bus shelter, and identify any existing bus features such as noticeboards, seats affected by the linkway connection, which would have an impact on the layout of the covered linkway.</li> </ul>
	<b>Connections and Interfaces at Development Boundary</b>
	<ul style="list-style-type: none"> <li>For covered linkways connecting to within the development site, to submit layout plans and section details at the interface, showing the RRL, alignment, floor levels, and headroom.</li> <li>To delineate the portion of linkway to be maintained by developer. Handed over to LTA for management.</li> </ul>
	<b>POB Layout</b>
	<ul style="list-style-type: none"> <li>To show the proposed alignment, width, and headroom (min 5.7m), of the POB.</li> <li>To establish the column size and position within / outside the road reserve. Min. lateral clearance from the road shall be provided.</li> </ul>
	<b>Connections and Interfaces at Development Boundary</b>
	<ul style="list-style-type: none"> <li>Where the POB connects to within the development site, to submit layout plans and section details at the interface, showing the RRL, alignment, floor levels and headroom.</li> <li>To delineate the portion of POB to be maintained by developer / handed over to LTA for management.</li> </ul>
	<b>Pedestrian Underpass Layout</b>
	<ul style="list-style-type: none"> <li>To submit cross section details showing the overburden i.e. depth of UPN from road levels.</li> <li>To show the proposed alignment, width, ceiling height / headroom, of the UPN.</li> <li>To ensure that the provision of lifts / escalators / staircase is adequate.</li> </ul>
	<b>Connections and Interfaces at Development Boundary</b>
	<ul style="list-style-type: none"> <li>To submit layout plans and section details at the interface, where the UPN connects to within the development site.</li> <li>To delineate the portion of UPN to be maintained by developer. handed over to LTA for management.</li> </ul>
	<b>Layout of Bus Stop</b>
	<ul style="list-style-type: none"> <li>To show the location of the bus stop.</li> <li>To show the position, and dimensions of the bus bay/ bus box.</li> <li>To show the proposed location, alignment, and dimensions of the bus shelter.</li> <li>To indicate the location of the bus pole.</li> <li>To relocate existing Manhole located on the future bus bay, if any.</li> </ul>
	<b>Connections and Interfaces at Development Boundary</b>
	<ul style="list-style-type: none"> <li>For bus stops directly integrating with the development infrastructure, to submit layout plans and sectional details of the bus shelter and bus bay/ bus box.</li> </ul>



# LTA's External Works Requirements

Legend: ■ Architecture ■ C&S ■ M&E

<b>G1</b>	<b>Design Gateway</b>
<b>Objective:</b>	
✓ To establish development platform level and development access that will properly interface with the proposed carriageway	
✓	<b>Requirements for Commuter Facilities</b>
	<p><b>Layout of Taxi Shelter</b></p> <ul style="list-style-type: none"> <li>To show the proposed layout of the taxi stand indicating the location of the taxi shelter, width and length of the taxi bay.</li> <li>To relocate existing Manhole located on the future taxi bay, if any.</li> </ul> <p><b>Connections and Interfaces at Development Boundary</b></p> <ul style="list-style-type: none"> <li>For taxi shelters directly integrating with the development infrastructure, to submit layout plans and sectional details of the taxi shelter.</li> </ul>
✓	<b>Requirements for Active Mobility Infrastructure</b>
	<p><b>Cycling Path Layout</b></p> <ul style="list-style-type: none"> <li>To show the proposed layout, width, and alignment of the cycling path.</li> <li>To indicate the gradient of cycling path if it is steeper than 1:25.</li> <li>To determine if widening of existing pedestrian crossing is required.</li> <li>To determine if additional lightings are required.</li> </ul>



# LTA's External Works Requirements

Legend: ■ Architecture ■ C&S ■ M&E

<b>G2 Construction Gateway</b>
<b>Objective:</b>
✓ To finalise all other details necessary for construction of the road and related infrastructure works
✓ <b>Requirements for Road Infrastructure and Vehicle Access</b>
<b><u>Vehicular Access Point Details</u></b>
<b><u>Connections and Interfaces at Development Boundary</u></b>
<ul style="list-style-type: none"> <li>To reflect the details presented at Design Gateway (G1) Stage.</li> <li>To show the structural details of entrance culvert at access points i.e., reinforcement, connection to entrance approach etc.</li> <li>To indicate the position of the 'Stop' line and 'Stop' sign (if required)</li> <li>To indicate the position of the '1-way' arrow (if required)</li> <li>To show that any redundant accesses are sealed and reinstated to match the existing side-table.</li> </ul>
<b><u>Details of External Works (Frontage Improvement Works)</u></b>
<ul style="list-style-type: none"> <li>To reflect all details presented at Design Gateway (G1) stage.</li> <li>To submit the Traffic Plan.</li> <li>To submit the street plan and cross section details showing the proposed levels, width and cross-fall of carriageway, planting verge and footpath.</li> <li>To clearly specify the size of proposed cross-culverts, and establish maintenance agreements with the relevant agencies (for cross-culverts less than 2m wide, to seek concurrent clearance with PUB Drainage)</li> <li>To submit the streetlighting plan (if applicable).</li> </ul>
<b><u>Details of Side Table Modifications for Addition of Auxillary Lanes, u-turns etc</u></b>
<ul style="list-style-type: none"> <li>To incorporate all details presented at Design Gateway (G1) stage.</li> <li>To submit the Traffic Plan</li> <li>To submit the street plan, clearly indicating the layout plan, longitudinal section and cross section details, such as the proposed levels, width and cross-fall of carriageway, planting verge and footpath.</li> <li>To clearly specify the size of proposed cross-culverts, and establish maintenance agreements with the relevant agencies (for cross-culverts less than 2m wide, to seek concurrent clearance with PUB Drainage)</li> <li>To submit the streetlighting plan (if applicable).</li> </ul>
<b><u>Details of New Street (incl. modifications to existing streets)</u></b>
<ul style="list-style-type: none"> <li>To incorporate all details presented at Design Gateway (G1) stage.</li> <li>To submit the Traffic Plan</li> <li>To submit the street plans, clearly indicating the layout plan, longitudinal section, and cross section details.</li> <li>To submit geotechnical details for foundation, retaining wall, slope (if any)</li> <li>To submit structural and M&amp;E details for road structures and associated commuter facilities.</li> <li>To submit the street lighting plan.</li> </ul>
<b><u>Street Works Deposit</u></b>
<ul style="list-style-type: none"> <li>For private developments with proposed major road infrastructure works (e.g. new streets, major improvement of an existing street, POB, UPN), to determine, and furnish the amount to be deposited with LTA for the execution and completion of the proposed street works.</li> </ul>





# LTA's External Works Requirements

Legend: ■ Architecture ■ C&S ■ M&E

<b>G2 Construction Gateway</b>
<b>Objective:</b>
✓ To finalise all other details necessary for construction of the road and related infrastructure works
✓ <b>Requirements for Commuter Facilities</b>
<p><b><u>Detailed Architectural / Structural Layout, and M&amp;E provisions of Covered Linkways</u></b></p> <ul style="list-style-type: none"> <li>To reflect all details presented at Design Gateway (G1) stage.</li> </ul> <p><b><u>Architectural Details</u></b></p> <ul style="list-style-type: none"> <li>To submit the 'Architectural Checklist for Covered Linkways'.</li> <li>To ensure that the proposed architectural design complies with the architectural requirements listed within the checklist.</li> <li>For covered linkways connecting/ interfacing with bus stops, to provide details of connection/bus stops, e.g. relocation of bus shelter elements.</li> </ul> <p><b><u>Structural Details</u></b></p> <ul style="list-style-type: none"> <li>To provide structural details (i.e. column width, footing), materials.</li> <li>To establish the column size and position within the road reserve.</li> <li>To determine if column footing will impact the top slab of the box drain, and coordinate (with PUB).</li> </ul> <p><b><u>M&amp;E Details</u></b></p> <ul style="list-style-type: none"> <li>To submit the 'M&amp;E Checklist for Bus Shelter, Taxi/ Passenger Pick-Up Shelter, Pedestrian Overhead Bridge (POB) and Covered Linkway'</li> <li>To ensure that the proposed design complies with the M&amp;E requirements listed in the checklist.</li> </ul> <p><b><u>Connections and Interfaces at Development Boundary</u></b></p> <ul style="list-style-type: none"> <li>For covered linkways connecting to within the development site, to provide details of connection/interfaces with development.</li> </ul> <p>Note: Refer to LTA's infrastructure Design Criteria, M&amp;W Specification, Architectural Design Checklist for Covered Linkways, and M&amp;E Checklist for a full list of requirements/ detailed description</p>
<p><b><u>Detailed Structural Layout, and M&amp;E provisions of Pedestrian Overhead Bridges</u></b></p> <ul style="list-style-type: none"> <li>To reflect all details presented at Design Gateway (G1) stage.</li> </ul> <p><b><u>Architectural &amp; Structural Details</u></b></p> <ul style="list-style-type: none"> <li>To submit the architectural checklist for the Pedestrian Overhead Bridge.</li> <li>To ensure that the proposed architectural design complies with the architectural requirements listed within the checklist.</li> <li>To provide structural details of POB (i.e. column width, footing).</li> </ul> <p><b><u>M&amp;E Details</u></b></p> <ul style="list-style-type: none"> <li>To submit the 'M&amp;E Checklist for Bus Shelter, Taxi / Passenger Pick-Up Shelter, Pedestrian Overhead Bridge (POB) and Covered Linkway'</li> <li>To ensure that the proposed M&amp;E lighting design complies with the M&amp;E requirements listed in the checklist.</li> </ul> <p><b><u>Connections and Interfaces at Development Boundary</u></b></p> <ul style="list-style-type: none"> <li>For POBs connecting to within the development site, to provide details of connection/interfaces with development, in accordance to the guidelines listed in the checklist.</li> <li>To determine and advise possible road closure due to hoisting of link bridges.</li> </ul> <p>Note: refer to LTA's infrastructure Design Criteria, M&amp;W Specification, Architectural Design Checklist for Pedestrian Overhead Bridge (POB), and M&amp;E Checklist for a full list of requirements/ detailed description</p>



# LTA's External Works Requirements

Legend: ■ Architecture ■ C&S ■ M&E

<b>G2 Construction Gateway</b>
<b>Objective:</b>
✓ To finalise all other details necessary for construction of the road and related infrastructure works
✓ <b>Requirements for Commuter Facilities</b>
<p><b><u>Detailed Structural Layout, and M&amp;E Provisions of Bus Shelters</u></b></p> <p><b><u>Architectural &amp; Structural Details</u></b></p> <ul style="list-style-type: none"> <li>To submit architectural checklist for pedestrian underpass</li> <li>To ensure that the proposed architectural design complies with the architectural requirements listed within the checklist.</li> <li>To provide structural details of bus shelter, seating arrangement, bus info panels etc.</li> <li>To provide bollard and flooring details</li> <li>For covered linkways connecting/ interfacing with bus stops, to provide details of connection/bus stops, e.g., relocation of bus shelter elements</li> </ul> <p><b><u>M&amp;E Details</u></b></p> <ul style="list-style-type: none"> <li>To submit the 'M&amp;E Checklist for Bus Shelter, Taxi / Passenger Pick-Up Shelter, Pedestrian Overhead Bridge (POB) and Covered Linkway'</li> <li>To ensure that the proposed M&amp;E lighting design complies with the M&amp;E requirements listed in the checklist</li> </ul> <p><b><u>Connections and Interfaces at Development Boundary</u></b></p> <ul style="list-style-type: none"> <li>For bus stops directly integrating with the development infrastructure, to submit layout plans and sectional details of the bus shelter and bus bay / bus box</li> </ul> <p><b><u>Other Requirements</u></b></p> <ul style="list-style-type: none"> <li>To submit the Traffic Plan</li> <li>To confirm the need of temporary bus stop provision and its position.</li> <li>To confirm the relocation date and commissioning of the new bus stop.</li> </ul>
<p><b><u>Detailed Layout of Taxi Shelter</u></b></p> <p><b><u>Architectural &amp; Structural Details</u></b></p> <ul style="list-style-type: none"> <li>To submit Traffic Plan</li> <li>To submit architectural plans and section details for the taxi shelter</li> <li>To submit architectural checklist for the taxi shelter</li> <li>To provide structural details of taxi shelter, seating arrangement, etc.</li> <li>To provide bollard and flooring details</li> <li>To provide details of lighting provisions and M&amp;E provisions (if any)</li> <li>Taxi pole</li> </ul> <p><b><u>M&amp;E Details</u></b></p> <ul style="list-style-type: none"> <li>To submit the 'M&amp;E Checklist for Bus Shelter, Taxi / Passenger Pick-Up Shelter, Pedestrian Overhead Bridge (POB) and Covered Linkway'</li> <li>To ensure that the proposed M&amp;E lighting design complies with the M&amp;E requirements listed in the checklist</li> </ul> <p><b><u>Connections and Interfaces at Development Boundary</u></b></p> <ul style="list-style-type: none"> <li>For taxi stands directly integrating with the development infrastructure, to submit layout plans and sectional details of the taxi stand and bay.</li> <li>To confirm the need of temporary taxi provision and its position.</li> </ul>

----- **End of External Works Requirements for LTA** -----

For the rest of LTA's requirements, please refer to [Page 56](#).



## Overview of NParks' External Works

Note that External Works is undergoing further refinements. More updates will be released in future COP versions.

Key Gateways	Objective	Details to be prepared (other details to be prepared and submitted as required)	Supporting Information required
<b>Pre-DG (Land Use, TCOT, PAFS, TIA)</b>	<ul style="list-style-type: none"> <li>To ensure RRL can accommodate standard roadside tables and additional commuter infrastructure</li> <li>To conserve specific roadside trees</li> <li>To ensure existing / proposed park / park connector is safeguarded</li> </ul>	<ul style="list-style-type: none"> <li>Width of Road Reserve (incl. planting verge within side table)</li> <li>Proposed road alignment</li> <li>Proposed cycling path alignment as safeguarded on SDCP under MP19</li> <li>If applicable:                             <ul style="list-style-type: none"> <li>URA/MND's conveyance on Form B</li> <li>EIA report</li> <li>EMMP</li> <li>Wildlife management plan</li> </ul> </li> </ul>	<ul style="list-style-type: none"> <li>Topo Survey (if applicable)</li> </ul>
<b>Pre-Submission, Planning and Other Consultations</b>	<ul style="list-style-type: none"> <li>To clarify how proposal may affect roadside verges and trees, and/or existing / proposed parks / park connectors</li> <li>To advise on greenery provisions and tree conservation</li> </ul>	<ul style="list-style-type: none"> <li>Proposal with safeguarded RRL and indicative entrance position and road alignment</li> <li>Proposal with Walking &amp; Cycling Plan</li> <li>If applicable:                             <ul style="list-style-type: none"> <li>URA/MND's conveyance on Form B</li> <li>EIA report</li> <li>EMMP</li> <li>Wildlife management plan</li> </ul> </li> </ul>	<ul style="list-style-type: none"> <li>Topo Survey Plan</li> </ul>
<b>Design Gateway (G1)</b>	<ul style="list-style-type: none"> <li>To secure greenery provisions and to comment on conservation of trees (may require Certified Arborist report, e.g. recommendations pertaining to works near to, but may not be directly impacting trees)</li> <li>To assess impact to existing, or safeguard provision of new, park / park connector</li> </ul>	<ul style="list-style-type: none"> <li>Standard roadside greenery provision (especially new roads), i.e. gradient, width and depth of green verge (incl. tree planting verge) according to road category including interfacing with internal works</li> <li>Spatial provision (width and depth) for greenery at Covered Linkways / Pedestrian Overhead Bridge</li> <li>Conservation of trees / plants (identification, e.g. trees within road reserve, heritage trees, trees identified in TCOT)</li> <li>Entrance(s) position and access point (s) location (e.g. for FEA, maintenance and pedestrians, to ensure sufficient clearance secured for the retention of mature roadside trees)</li> <li>New Parks / Park connector / Promenade</li> </ul>	<ul style="list-style-type: none"> <li>Topo survey plan</li> <li>Arborist report (Please refer to NParks' Guidelines [Chapter 2])</li> <li>Services detection plan</li> <li>Photos of existing trees (if not in Arborist report)</li> </ul>
<b>Piling Gateway (G1.5) (Optional)</b>	-	-	-
<b>Construction Gateway (G2)</b>	To ensure dimensions of green verges are compliant with standard requirements / accepted by NParks at Design Gateway (G1)	<ul style="list-style-type: none"> <li>Dimensions of green verges compliant with standard requirements / as approved by NParks at Design Gateway (G1)</li> <li>Landscaping scheme for roadside greenery by Applicant</li> </ul>	-
<b>Independent Submissions</b>	To finalise details on roadside tree planting and landscaping works, as well as transplanting works	<ul style="list-style-type: none"> <li>Reinstatement works for green verge (without tree planting)</li> <li>Landscaping scheme for roadside greenery undertaken by NParks</li> <li>Planting Requirements for Covered Linkways / Pedestrian Overhead Bridge</li> </ul>	<ul style="list-style-type: none"> <li>Dimensions (length, width) of green verges to aid cost estimate for landscaping works (only if NParks were to undertake works)</li> <li>Specifications for trellis planting, green roof, planter boxes for covered linkways / POB (where applicable).</li> </ul>

Useful Link(s):

[NParks' Guidelines](#)

[NParks Flora and Fauna Web](#)



# NParks' External Works Requirements

## G1 Design Gateway

### Objective:

- ✓ To secure greenery provisions and to comment on conservation of trees (may require Certified Arborist report, e.g. recommendations pertaining to works near to, but may not be directly impacting trees)
- ✓ To assess impact to existing, or safeguard provision of new, park / park connector

Requirements	Supporting Documents
<p><b><u>Conservation of Trees</u></b></p> <ul style="list-style-type: none"> <li>• To conserve trees identified:                             <ul style="list-style-type: none"> <li>• In Technical Conditions of Tender (TCOT)</li> <li>• As Heritage Trees</li> <li>• Through nature group / public / residents engagement</li> <li>• In Environmental Impact Assessment (EIA)/ Environmental Management and Monitoring Plan (EMMP) etc.</li> </ul> </li> </ul>	Arborist report (Please refer to NParks' Guidelines [Chapter 2])
<p><b><u>Green Verges</u></b></p> <ul style="list-style-type: none"> <li>• To provide green verges (consisting of tree planting and service verges) for street work proposals relating to development works and for new road services according to the road category</li> <li>• To locate fire engine accessways outside green verges</li> <li>• <u>Road and Commuter Infrastructure</u> <ul style="list-style-type: none"> <li>○ To comply with greenery provision for covered linkways, bus shelters, pedestrian overhead bridges, depressed road portals, road viaducts/flyovers and retaining walls etc. according to NParks' Guidelines (Chapter 4)</li> </ul> </li> <li>• <u>Entrance Culvert Position (at Vehicular Access Points)</u> <ul style="list-style-type: none"> <li>○ To ensure splay corners do not affect green verge provision and roadside trees</li> </ul> </li> </ul>	-
<p><b><u>Biodiversity Impact Assessment (under URA's Environmental Impact Assessment [EIA] framework)</u></b></p> <ul style="list-style-type: none"> <li>• Applicable to sites that fall within the EIA Framework but were not identified at Planning Stage (Pre-DG)</li> <li>• <u>Environmental Consultation</u> <ul style="list-style-type: none"> <li>○ QP (Arch / PEs) or Consultant to submit the environmental consultation form (Form A) to URA and Technical Agencies (e.g. NEA, NParks, MPA, SFA)</li> <li>○ Details of project entities (Developer, Qualified Person and Main Contractor) as stated in Form A are provided</li> </ul> </li> <li>• <u>Environmental Impact Assessment (EIA)</u> <ul style="list-style-type: none"> <li>○ If determined during environmental consultation that an environmental study is needed, QP (Arch / PEs) or Consultant can consult on environmental baseline study and scoping of EIA</li> <li>○ QP (Arch / PEs) or Consultant to ensure that EIA report (for projects that have cleared environmental assessment at planning stage) are submitted for acceptance</li> </ul> </li> </ul>	-

Useful Link(s):

[NParks' Guidelines](#)

[NParks Flora and Fauna Web](#)



# NParks' External Works Requirements

<b>G2 Construction Gateway</b>		
<b>Objective:</b>		
✓ To ensure dimensions of green verges are compliant with standard requirements / accepted by NParks at Design Gateway (G1)		
	<b>Requirements</b>	<b>Supporting Documents</b>
	<p><b>Conservation of Trees</b></p> <ul style="list-style-type: none"> <li>To conserve trees identified:                             <ul style="list-style-type: none"> <li>In Technical Conditions of Tender (TCOT)</li> <li>As Heritage Trees</li> <li>Through nature group / public / residents engagement</li> <li>In Environmental Impact Assessment (EIA)/ Environmental Management and Monitoring Plan (EMMP) etc.</li> </ul> </li> </ul>	Arborist report (Please refer to NParks' Guidelines [Chapter 2])
	<p><b>Provision of Green Verges</b></p> <ul style="list-style-type: none"> <li>To ensure dimensions of green verges are compliant with NParks' Guidelines (Chapter 3) or as approved by NParks during Design Gateway (G1)</li> </ul>	-
	<p><b>Interfacing Aspects (from within Development Boundary)</b></p> <ul style="list-style-type: none"> <li>To show layouts and cross-sections of interfaces in external works design proposal</li> </ul>	-
	<p><i>Applicable to sites not requiring Piling Gateway (G1.5) approval</i></p> <p><b>Applicable to sites requiring Environmental Monitoring and Management Plan (EMMP) / Wildlife Management Plan prior to commencement of works:</b></p> <ol style="list-style-type: none"> <li>Detailed EMMP report (provided by Main Contractor)</li> <li>Acceptance letter from NParks prior to site clearance (if applicable)</li> </ol>	-

<b>- Independent Submissions</b>		
<b>Objective:</b>		
✓ To finalise details on roadside tree planting and landscaping works, as well as transplanting works		
	<b>Requirements</b>	<b>Supporting Documents</b>
	<p><b>Planting Scheme (Outside Development Boundary)</b></p> <ul style="list-style-type: none"> <li>To show location, number and species of existing and proposed trees/shrubs for green verges and planter troughs along pedestrian overhead bridges/ road viaducts/ flyovers</li> </ul>	-

----- **End of External Works Requirements for NParks** -----

For the rest of NParks requirements, please refer to [Page 71](#).



## Overview of PUB's External Works

Note that External Works is undergoing further refinements. More updates will be released in future COP versions.

Key Gateways	Objective	Details to be prepared (other details to be prepared and submitted as required)	Supporting Information required
<b>Pre-DG (Land Use, TCOT, PAFS, TIA)</b>	To establish development boundary, any Drainage Reserve (DR), drain size for affected / proposed public drain and sewer connection, water pipe diversion requirements	Site plan overlay with PUB Services Plans (Drainage Interpretation Plan, Sewerage Information Plan and Water Service Plan) showing the drainage reserves or land reserved for future drainage schemes, common drain, location and alignment of public sewers or pumping mains, and approximate position of the water mains and raw water mains in the vicinity of the development.	<ul style="list-style-type: none"> <li>Site plan with drainage, sewerage and water main information</li> <li>Sewer discharge quantity</li> <li>Water demand</li> </ul>
<b>Pre-Submission, Planning and Other Consultations</b>	To seek clarifications for details to be submitted at Design Gateway (G1) stage	<p><u>Key evaluation areas include:</u></p> <ul style="list-style-type: none"> <li>Any storm water drainage works, erection or placement of any structures or object in, above or across any drain or drainage reserve</li> <li>Any temporary structure / works / services over, across or adjacent to any drain or storm water drainage system</li> <li>Any proposed realignment of Drainage Reserve or Drainage Reserve to be set aside and vested to State;</li> <li>Any works which could affect any public sewers / sewerage system or public drains including common drains directly or indirectly;</li> <li>Any buildings or structures to be erected over, across or adjacent to any public sewerage system; and</li> <li>Proposed connection of the development / premises to the public sewers / sewerage system</li> </ul>	<ul style="list-style-type: none"> <li>Architectural / Engineering drawings</li> <li>Topo Survey Plan</li> </ul>
<b>Design Gateway (G1)</b>	<ul style="list-style-type: none"> <li>To establish MPL requirements</li> <li>To assess proposed works affecting drainage (e.g. management of maximum allowable peak runoff, discharge point of internal drains) and linkages to underground Special Facilities (e.g. Rapid Transit System)</li> <li>To assess proposed works affecting sewer (e.g., capacity, setback, sewer connection, alignment and size for diversions)</li> </ul>	<p><u>Key evaluation areas include:</u></p> <ul style="list-style-type: none"> <li>Any storm water drainage works, erection or placement of any structures or object in, above or across any drain or drainage reserve</li> <li>Any temporary structure / works / services over, across or adjacent to any drain or storm water drainage system</li> <li>Any proposed realignment of Drainage Reserve or Drainage Reserve to be set aside and vested to State;</li> <li>Any works which could affect any public sewers / sewerage system or public drains including common drains directly or indirectly;</li> <li>Any buildings or structures to be erected over, across or adjacent to any public sewerage system; and</li> <li>Proposed connection of the development / premises to the public sewers / sewerage system</li> </ul>	<ul style="list-style-type: none"> <li>Architectural / Engineering drawings</li> <li>Topo Survey Plan</li> </ul>
<b>Piling Gateway (G1.5) (Optional)</b>	Prior to commencement of piling works, QP / PE shall obtain approval for relevant works (works requiring Earth Control Measures, specified activities within water and sewer pipe corridor)	Details of specified activities within water and sewer pipe corridor, temporary works affecting drains, within drainage reserve etc. where applicable as listed under "Independent Submissions"	<ul style="list-style-type: none"> <li>Engineering drawings</li> <li>Topo Survey Plan</li> <li>Method Statement</li> <li>Engineering calculations</li> <li>PE endorsed reports</li> </ul>



## Overview of PUB's External Works

Note that External Works is undergoing further refinements. More updates will be released in future COP versions.

Key Gateways	Objective	Details to be prepared (other details to be prepared and submitted as required)	Supporting Information required
<b>Construction Gateway (G2)</b>	To evaluate the detailed plans showing the proposed drainage (e.g. upgrading, new construction) and sewerage works (e.g. sewer diversion)	<ul style="list-style-type: none"> <li>• Works affecting Sewer (e.g. proposed sewers / manhole, pump sumps / pumping main, abandon sewers/manhole, RC Trench for housing the public sewer)</li> <li>• Works affecting Drainage (e.g. common drain, Drainage Reserve entrance culvert / roadside drain, slab over drain for meter compartment)</li> </ul>	<ul style="list-style-type: none"> <li>• Engineering drawings</li> <li>• Engineering calculations</li> <li>• PE endorsed reports</li> </ul>
<b>Independent Submissions</b>	To obtain PUB's approval for works / site activities within RRL affecting drainage, sewerage or water services (where applicable)	<p><u>Drainage</u></p> <ul style="list-style-type: none"> <li>○ Earth Control Measures (ECM) Plan</li> <li>○ Details of temporary works affecting drainage/within drainage reserve</li> </ul> <p><u>Sewerage / Sanitary</u></p> <ul style="list-style-type: none"> <li>○ Details and scope of works on manholes and sewers</li> <li>○ Specified activities within sewer corridor</li> </ul> <p><u>Water</u></p> <ul style="list-style-type: none"> <li>○ Site plans, water reticulation schematic / layout drawing of WSI design works and water requirements</li> <li>○ Specified activities within water pipe corridor</li> </ul>	<ul style="list-style-type: none"> <li>• Engineering drawings</li> <li>• Topo Survey Plan</li> <li>• Method Statement</li> <li>• Engineering Calculations</li> <li>• PE endorsed reports</li> </ul>



## PUB's External Works Requirements

<b>G1 Design Gateway</b>	
<b>Objective:</b>	
✓ <b>To assess whether the proposed drainage and sewerage works are in compliance with broad planning parameters (e.g. maximum allowable peak runoff, sewer setback, connection to public sewer etc.)</b>	
Requirements	Supporting Documents
<b><u>Peak Run Off</u></b> <ul style="list-style-type: none"> <li>Key Objective: To demonstrate how this is catered for, area is set aside for detention tank provision, location, OR drain widening</li> <li>Calculation of peak run off factor (C value) max. 0.55 (based on code and chart) e.g. area of development of greenfield site</li> </ul>	-
<b><u>Roadside Drain Capacity</u></b> <ul style="list-style-type: none"> <li>For projects where drains need to be rebuilt / entrance culvert. PUB to provide required capacity during Pre-Submission consultation</li> <li>Size of new culvert (will be advised by PUB)</li> <li>Public Drains - Drain Size and Location</li> </ul>	-
<b><u>Sewer Connection</u></b> <ul style="list-style-type: none"> <li>Connection Point – where the proposed location is</li> </ul>	-
<b><u>Sewerage System</u></b> <ul style="list-style-type: none"> <li>Alignment of Sewers, Dimensions, Gradient</li> </ul>	-
<b><u>Drainage Reserve</u></b> <ul style="list-style-type: none"> <li>Location (align to DIP), width</li> </ul>	-

<b>G1.5 Piling Gateway (Optional)</b>	
<b>Objective:</b>	
✓ <b>Prior to commencement of piling works, QP / PE shall obtain approval for relevant works (works requiring Earth Control Measures, specified activities within water and sewer pipe corridor)</b>	
Requirements	Supporting Documents
 <b><u>Pre-Condition CCTV of Sewers (advisable)</u></b> <i>Can be provided at Piling Gateway (G1.5) or Construction Gateway (G2)</i> <ul style="list-style-type: none"> <li>Condition to be checked at TOP stage</li> <li>Project team to rectify if cracks / damage are identified</li> </ul>	-





## PUB's External Works Requirements

<b>G2 Construction Gateway</b>		
<b>Objective:</b>		
✓ To evaluate the detailed plans showing the proposed drainage (e.g. upgrading, new construction) and sewerage works (e.g. sewer diversion)		
Requirements	Supporting Documents	
<b><u>Public Drains (External)</u></b> <ul style="list-style-type: none"> <li>Details of Roadside Drains based on PUB's requirements</li> </ul>	-	
<b><u>Public Sewerage System (External)</u></b> <ul style="list-style-type: none"> <li>Details of Sewerage System based on PUB's requirements</li> </ul>		

<b>- Independent Submissions</b>		
<b>Objective:</b>		
✓ To evaluate the detailed plans showing the proposed drainage (e.g. upgrading, new construction) and sewerage works (e.g. sewer diversion)		
Requirements	Supporting Documents	
<ul style="list-style-type: none"> <li>Site plans, water reticulation schematic / layout drawing of WSI design works and water requirements</li> <li>Specified activities within water pipe corridor</li> </ul>	-	
<ul style="list-style-type: none"> <li>Earth Control Measures (ECM) Plan</li> <li>Details of temporary works affecting drainage / within drainage reserve</li> </ul>	-	
<ul style="list-style-type: none"> <li>Details and scope of works on manholes and sewers</li> <li>Specified activities within sewer corridor</li> </ul>	-	

----- **End of External Works Requirements for PUB** -----

For the rest of PUB's requirements, please refer to [Page 74](#).

## Direct Submission Process (DSP)

### ► About

- While the multi-gateway RABW will be the default regulatory process for most applications, simpler development typologies (e.g. single-unit residential development, standalone pavilion / linkway, racking system, etc.) need not be subjected to the typical RABW 3-Gateway Process, and can be approved through a more direct process.
- Instead of multiple touchpoints at Design Gateway, Piling Gateway (optional) and Construction Gateway, the Direct Submission Process (DSP) is developed as a **single-stage approval** prior to TOP/CSC.
- Industry can carry out pre-submission consultations with Agencies before proceeding with DSP with greater certainty
- Eligible projects will be put under DSP. Through the guided submission process, projects will also be put through lodgement / self-declaration / simplified submission scheme if eligible.

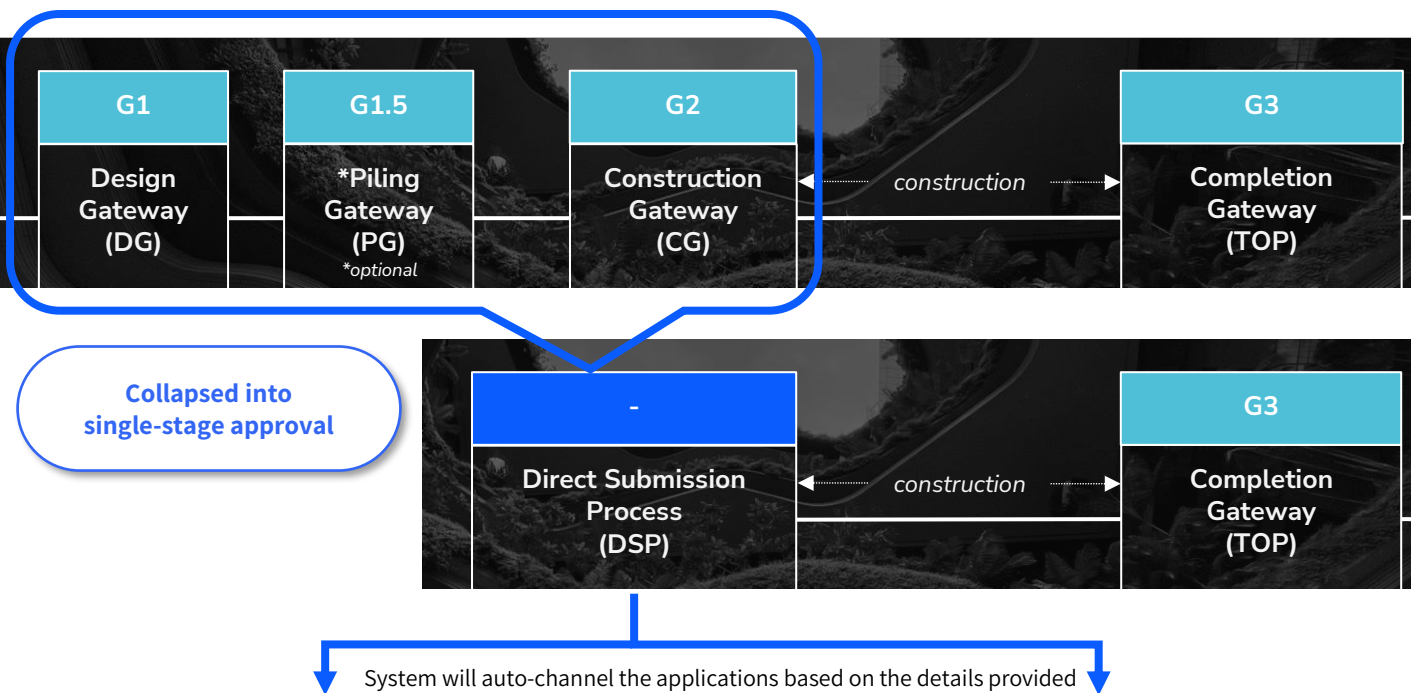

#### One Stage Lodgement / Self-Declaration

- Models/drawings submitted, together with **QP declarations** on compliance with regulatory requirements
- Once received, the relevant agencies will issue acknowledgement(s) of the submission
- Audits may be conducted by agencies
- In the event the submission is not in order or assessed to be ineligible for lodgement/self-declaration scheme, the relevant agency will issue Written Direction. The submission will then be placed under 'Plan Application' during re-submission

#### One Stage Plan Check for Approval

- **Agencies directly assess plan application** submission. Work will not be allowed to commence until after such approvals are granted



# Conservation

Legend:



Architecture



C&S



M&E

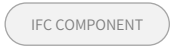

Note that Conservation projects are in the exploratory phase of CORENET X submissions and do not need to be submitted in IFC-SG. More updates will be released in future COP versions.

- Pre-Submission, Planning and Other Consultations	
Key Words	Requirement Category
Conservation	<p><b>Monument</b></p> <p>Applicant is to obtain Preservation of Sites and Monuments (PSM)'s endorsement of the proposal prior to making the Design Gateway submission.</p>

G1 Design Gateway	
Key Words	Requirement Category
<p>Conservation</p> <p>SITE BOUNDARY</p> <p>SLAB</p> <p>BUILDING STOREY</p> <p>WALL</p> <p>SPACE</p> <p>SITE</p>	<p><b>Building Form</b></p> <ul style="list-style-type: none"> <li>Building height</li> <li>Building profile and extent of conserved building and/or monument</li> <li>Building profile of new extension and new envelop control developments</li> <li>Setback of new extension from conserved building and/or monument</li> <li>Interfacing zone and linkage to conserved building and/or monument</li> </ul> <p><b>Levels</b></p> <ul style="list-style-type: none"> <li>Five-footway and internal building finished floor levels</li> <li>Existing and proposed levels of surrounding open walkway or compound</li> </ul> <p><b>Party-wall Developments</b></p> <ul style="list-style-type: none"> <li>Height levels (i.e. Roof ridge and eave, covered and open walkways) of immediately adjacent party wall developments</li> </ul> <p><b>Roof</b></p> <ul style="list-style-type: none"> <li>Profile, pitch and height</li> <li>Rooftop structure on existing flat roof, if any</li> <li>Mono-pitched link for Secondary Settlement</li> </ul> <p><b>Site Layout</b></p> <ul style="list-style-type: none"> <li>Location of conserved extent of building</li> </ul> <p><b>Supplementary Documents:</b></p> <ol style="list-style-type: none"> <li>Business concept and furniture layout of proposed use for change of use in Historic Conservation Area (HCA)</li> <li>(For non-BIM submission) Measured survey drawing (for unrestored building)</li> <li>(For BIM submissions) BIM model of existing building for unrestored building or BIM model of approved plan for restored building *</li> <li>Façade and interior photographs</li> <li>Development Statement of Intent (DSI)</li> <li>Design Advisory Panel (Conservation) (DAPC) presentation material, if required</li> <li>Documentation of existing buildings, if required</li> </ol> <p>Note: Extent of proposals to the above should be clearly indicated e.g. repair of existing, retention of existing, reinstatement of missing elements, 1-for-1 replacements or proposed removal.</p> <p>* A restored building is a conserved building which has been restored according to the conservation guidelines and has been issued a Certificate of Statutory Completion (CSC) clearance.</p>



# Conservation

Legend:  Architecture  C&S  M&E IFC COMPONENT

Note that Conservation projects are in the [exploratory phase](#) of CORENET X submissions and do not need to be submitted in IFC-SG. More updates will be released in future COP versions.

G2 Construction Gateway - All Design Gateway requirements will apply, in addition to the following :-	
Key Words	Requirement Category
<div style="display: flex; flex-direction: column; align-items: center;"> <div style="width: 100%; height: 100%; background-color: orange; margin-bottom: 5px;"></div> <div style="width: 100%; height: 100%; background-color: green; margin-bottom: 5px;"></div> <div style="width: 100%; height: 100%; background-color: yellow;"></div> </div> <div style="margin-top: 10px;"> <p>Conservation</p> <div style="display: flex; flex-wrap: wrap; gap: 10px;"> <div style="border: 1px solid gray; border-radius: 10px; padding: 2px 10px; background-color: #f2f2f2;">COLUMN</div> <div style="border: 1px solid gray; border-radius: 10px; padding: 2px 10px; background-color: #f2f2f2;">DOOR</div> <div style="border: 1px solid gray; border-radius: 10px; padding: 2px 10px; background-color: #f2f2f2;">WALL</div> <div style="border: 1px solid gray; border-radius: 10px; padding: 2px 10px; background-color: #f2f2f2;">WINDOW</div> <div style="border: 1px solid gray; border-radius: 10px; padding: 2px 10px; background-color: #f2f2f2;">SPACE</div> </div> </div>	<ul style="list-style-type: none"> <li>Architectural features (e.g. windows, doors, plaster moulding, roof and floor finishes)</li> <li>New Structural works (e.g. strengthening)</li> <li>Interventions (e.g. new roof mezzanine, lift, openings)</li> <li>M&amp;E installations (e.g. A/C units, flue)</li> </ul> <p>Note: Extent of proposals to the above should be clearly indicated e.g. repair of existing, retention of existing, reinstatement of missing elements, 1-for-1 replacements or deletions.</p> <p> <b>Documents to be part of Approved Plan (Conservation)</b></p> <p>a) Drawing or model of architectural details (e.g. decorative ornaments, doors, windows)</p> <p> <b>Supplementary Documents</b></p> <p>a) Structural report, method statement, protective measure, PE's endorsement (for new structural works)</p> <p>b) Structural drawing (for new structural works)</p> <p>c) Design Advisory Panel (Conservation) (DAPC) presentation material, if required</p> <p>d) (For non-BIM submission) Measured survey drawing (for unrestored building) (if not already submitted in full in Design Gateway (G1))</p> <p>e) (For BIM submissions) BIM model of existing building for unrestored building or BIM model of approved plan for restored building (if not already submitted in full in Design Gateway (G1))</p> <p>f) Heritage interpretation plan, if required</p>

- Independent Submission	
Key Words	Requirement Category
<div style="width: 100%; height: 100%; background-color: orange;"></div>	<p><b>Conserved Building (remaining works to be checked)</b></p> <ul style="list-style-type: none"> <li>Painting</li> <li>Signage</li> </ul>

----- **End of Conservation Requirements for URA** -----

[For the rest of URA's RABW requirements, please refer to Page 83.](#)



# Part ST Submissions

## About

Note that Part ST Submissions is undergoing further refinements. More updates will be released in future COP versions.

- Under the new Regulatory Approval for Building Works, project teams are required to collaborate and submit a set of coordinated models. Requirements imposed at each gateway are often major requirements that have cross agencies' dependencies.
- Agency specific requirements may be submitted as independent submissions subsequently. Some examples of structural submissions that can be submitted as an independent submission includes:
  - Structural submissions for ancillary works (eg: cladding, barrier)
  - Structural submissions for temporary works (eg: ERSS)
- Industry has raised concerns that while overall design can be done upfront, detailed structural calculations and AC/ACO reports take time to develop. Projects may face significant delay in commencement of works if everything must be submitted and cleared before the relevant approval and permit can be issued.
- To address these concerns, detailed structural design and calculations of eligible projects **need not** be submitted in a single attempt but done through a **limited number of part ST submissions**

## Criteria on Eligible Projects for Part ST Submissions

- Building projects (non-infrastructure projects):**
  - Any project with a **Gross Floor Area (GFA) > 40,000sqm** is eligible for part ST submission if –
    - the project consists of 5 or more blocks of building of at least 4 storeys high each; or
    - the project consists of 3 or more blocks of building of at least 4 storeys high each, with common podium or basement.
- Infrastructure works**
  - Infrastructure works that function like a building **with length > 150m** (e.g. MRT stations, transport nodes/ interchanges);
  - Infrastructure works that are mostly engineering works **with length > 400m** (e.g. viaducts, large scale drains, sewers)
  - Infrastructure works that are mostly coastal works **with length > 4,000m** (e.g. land reclamation, revetment, sea wall, bund wall)

## Flow of Part ST Submissions (Construction Gateway)

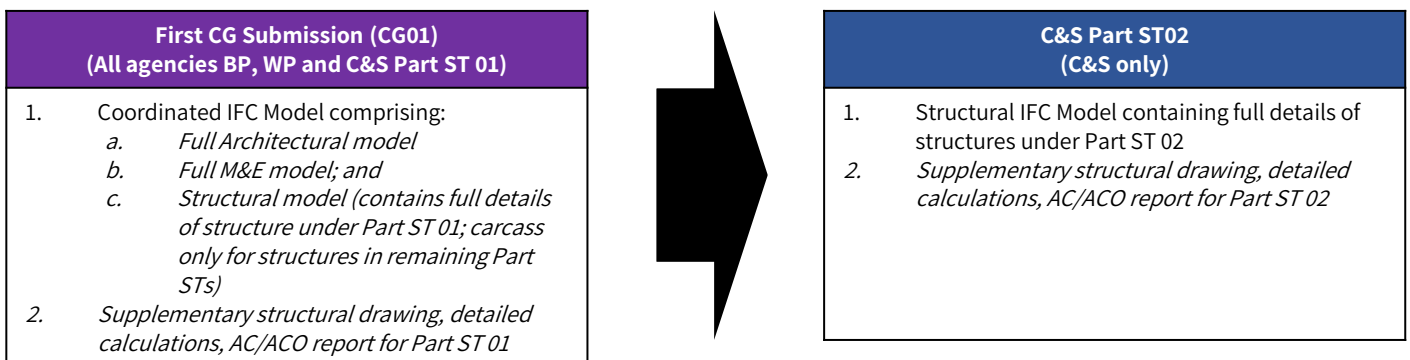

Approval for C&S Part ST can only be obtained after First CG is approved.



## Part ST Submissions

### ► Flow of Part ST Submissions (Construction Gateway) *(continued from previous page)*

When amendment is required:

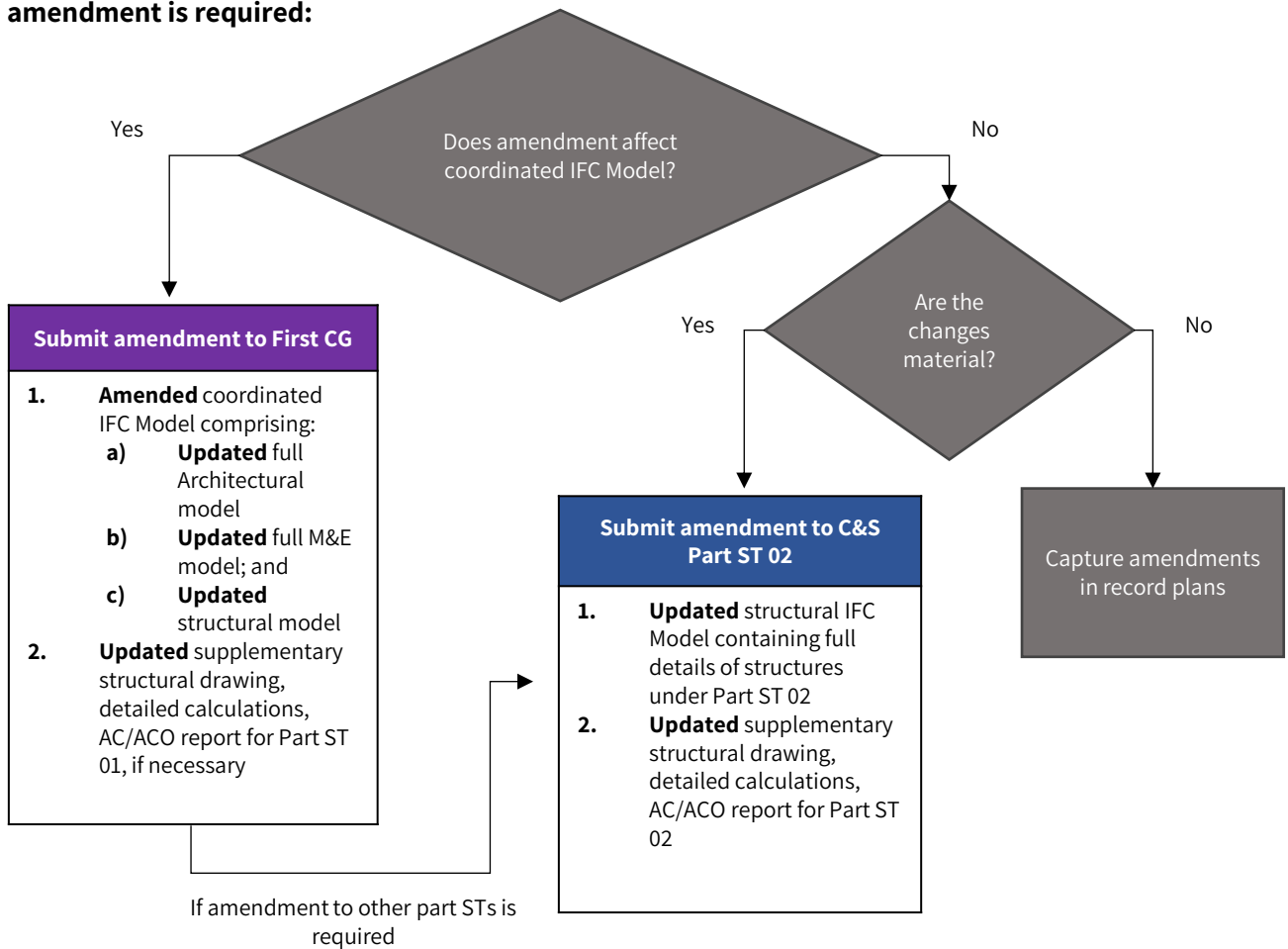

All amendments must be made to the original submission



## Part ST Submissions

### ► Guidelines for Part ST Submissions (Large Building Projects)

Note that Part ST Submissions is undergoing further refinements. More updates will be released in future COP versions.

Scope/Scale of Works	Number of Packages Allowed
Superstructure <ul style="list-style-type: none"> <li>E.g. consisting of <b>9 blocks</b></li> </ul>	1 no. of Part ST Submission for <b>every 4 blocks</b> <ul style="list-style-type: none"> <li>Split into <b>3 no.s of Part ST Submissions of equal size</b> (as far as possible): GFA for each of the submissions should cover about 1/3 of the total GFA of these blocks (i.e. if the total GFA is 105,000 sqm, each of the Part ST Submission should be about 35,000 sqm)</li> </ul>
Common Basement	1 no. of Part ST Submission
Common Podium	1 no. of Part ST Submission
All ancillary works	1 no. of Part ST Submission
All external works	1 no. of Part ST Submission
ERSS	Independent submission <i>*No change from the current arrangement under the standard RABW (without phasing)</i>
Cladding	
Façade	
Demolition	
Temporary Deck	

The project team should propose a phasing plan for structural submissions based on this guideline and seek agencies' concurrence at the pre-submission consultation, before making submissions.



## Part ST Submissions

### ► Guidelines for Part ST Submissions (Infrastructure Works)

Note that Part ST Submissions is undergoing further refinements. More updates will be released in future COP versions.

For more information on Infrastructure works, please refer [here](#).

- Infrastructure Works: Section of underground MRT Station

Section of underground MRT Station	Number of Part ST Submissions Allowed
Main station	1 no. of Part ST Submission for <b>every 150m</b> (rounded up to nearest unit)
Cut and cover tunnel, Open box tunnels	
Entrances/Exits	1 no. of Part ST Submission <b>each</b>
Launch shafts	1 no. of Part ST Submission <b>each</b>
Bored tunnels	1 no. of Part ST Submission <b>per direction</b>

- Infrastructure Works: Section of underground MRT Station

Section of Aboveground MRT Station	Number of Part ST Submissions Allowed
Main station	As per underground MRT station (1 no. of Part ST Submission for every 150m)
Entrances/Exits	As per underground MRT station (1 no. of Part ST Submission each)
MRT tracks	Aboveground – As per Railway Track (1 no. of Part ST Submission for every 400m) Underground – As per Bored Tunnel (1 no. of Part ST Submission per direction) or Cut and cover tunnel (1 no. of Part ST Submission for every 150m)

- Infrastructure Works: Railway tracks and viaducts

Infrastructures	Number of Part ST Submissions Allowed
Railway tracks and viaducts	1 no. of Part ST Submission for <b>every 400m</b> (rounded up to nearest unit)

- Infrastructure Works: Drainage and sewer

Infrastructures	Number of Part ST Submissions Allowed
Drainage and sewer	1 no. of Part ST Submission for <b>every 400m</b> (rounded up to nearest unit)





## Part ST Submissions

### ► Guidelines for Part ST Submissions (Infrastructure Works)

Note that Part ST Submissions is undergoing further refinements. More updates will be released in future COP versions.

For more information on Infrastructure works, please refer [here](#).

- Infrastructure Works: Land reclamation, revetment, sea wall, bund wall

Infrastructures	Number of Part ST Submissions Allowed
Land reclamation, revetment, sea wall, bund wall	1 no. of Part ST Submission for <b>every 4,000m</b> (rounded up to nearest unit)
	1 no. of Part ST Submission for <b>each</b> casting yard
	1 no. of Part ST Submission for dumping plan

-----  
**End of Part ST submission for BCA**  
-----



## Infrastructure Works

### About

Other than building projects, our built environment involves infrastructure projects supporting the various needs for our population. While similar, infrastructure projects face different sets of challenges from building projects. This section aims to guide the industry through the regulatory approval for infrastructure works.

### Categorisation of Infrastructure Works

Infrastructure works can be grouped into different categories:

#### Infrastructure that functions like a building

Infrastructure works that function like buildings

Examples include

- MRT Station (including exits)
- Transport nodes/ interchange
- Electrical substation
- Underground (UG) buildings such as UG MRT Station, UG substation

#### Intended Workflow

The workflow for this category will follow that of a building (i.e. 3 Gateway Process)

Refer to Section 3 for details

#### Civil Engineering Works that is external to a development

External works for new developments

To support a new development, it is important to ensure its integration with the surroundings and that the capacity of our public infrastructure meets the increasing demand brought by the new development

#### Intended Workflow

The workflow for this category will follow that of external works

Refer to details [here](#)

#### Public Infrastructure Works

Public infrastructure works undertaken by public agencies

Examples include:

- Precinct level infrastructure works carried out by developing agencies (e.g.: HDB, JTC)
- Railway track/ tunnels
- Viaducts

#### Intended Workflow

The workflow for this category will largely follow that of the 3 Gateway Process.

Refer to details below

### Regulatory Process for Public Infrastructure Works

The relevance of Design Gateway (in terms of the number of agencies involved) depends on various factors:

- The nature of the works
- The site condition and extent of infrastructure works
- Pre-submission consultations that might have taken place earlier

For instance, for a developing agency (such as JTC and HDB) carrying out precinct level infrastructure works to prepare the site for future developments, regulatory agencies such as LTA, PUB and NParks would be involved in the Design Gateway to align the various aspects such as the alignment of roads, drains, green verge, platform level etc.

On the other hand, in the case of underground railway tracks, fewer agencies would be involved as advance works such as service/traffic diversion and cutting of trees would have been carried out earlier as part of site preparation.

In gist, the Design Gateway and 3 gateway submission workflow remain relevant and viable to accommodate the range of infrastructure works. Depending on the works involved, the extent of details required at Design Gateway varies.



## Infrastructure Works

### ► Regulatory Agencies' Requirements relevant for Public Infrastructure Works

The below table summarises the type of approvals required by the key regulatory agencies.

Note: This is not meant to be an exhaustive list. If clarifications are required, please contact CORENET X helpdesk and relevant agency for clarification.

	Others (e.g.: Pre-sub process/consultation, Independent)	Design Gateway	Piling Gateway (optional)	Construction Gateway
URA	Must seek land use approval for the infra alignment prior to DG. For new roads & rail, proposed road/rail must keep within approved road reserve/railway area	<ul style="list-style-type: none"> <li>Buildings above and below ground e.g. ventilation buildings, MRT station boxes, entrances and associated structures.</li> <li>Proposals that deviate from the approved land use approval</li> </ul>	NIL	<ul style="list-style-type: none"> <li>Buildings above and below ground e.g. ventilation buildings, MRT station boxes, entrances and associated structures.</li> <li>Proposals that deviate from the approved land use approval</li> </ul>
LTA	Submission via LTA Prompt	<ul style="list-style-type: none"> <li>If within existing railway protection zone</li> <li>If works within road reserve/ affected by road structure safety zone</li> </ul>	If within existing railway protection zone	<ul style="list-style-type: none"> <li>If within existing railway protection zone</li> <li>If works within road reserve/ affected by road structure safety zone</li> </ul>
NParks	EIA, EMMP, advanced works e.g. tree cutting/ earthworks	<ul style="list-style-type: none"> <li>If new/affecting existing roadside trees, green verges and/or existing park/ Park connector/ nature area/ nature reserve/ heritage road green buffer, etc.</li> </ul>	NIL	<ul style="list-style-type: none"> <li>If new/affecting existing roadside trees, green verges and/or existing park/ Park connector/ nature area/ nature reserve/ heritage road green buffer, etc.</li> </ul>
PUB	<ul style="list-style-type: none"> <li>Access to sewers (Form B)</li> <li>Submission via B&amp;P Portal (POWS)</li> </ul>	<ul style="list-style-type: none"> <li>If new/ affecting existing sewer works</li> <li>If new/ affecting existing drainage works</li> </ul>	NIL	<ul style="list-style-type: none"> <li>If new/ affecting existing sewer works</li> <li>If new/ affecting existing drainage works</li> </ul>
NEA	EIA, NIA (for projects within 70m of resi/ noise sensitive developments)	<ul style="list-style-type: none"> <li>If within 70m of resi/ noise sensitive developments</li> <li>For any environmental health/ pollution control requirements</li> </ul>	NIL	<ul style="list-style-type: none"> <li>If within 70m of resi/ noise sensitive developments</li> <li>For any environmental health/ pollution control requirements</li> </ul>
BCA	Complex structures, ERSS etc.	NIL	If piling works involved	<ul style="list-style-type: none"> <li>For main structural works</li> </ul>
SCDF	Performance-based fire engineering	NIL	NIL	<ul style="list-style-type: none"> <li>For underground tunnels</li> </ul>



## Infrastructure Works

### ► Illustration of agencies' involvement at the various Gateways

The below table serves to give an illustration of possible types of projects and correspondingly the agencies' approvals required.

Note: This is not meant to be an exhaustive list. If clarifications are required, please contact CORENET X helpdesk and relevant agency for clarification.



	Type of infra works and site condition	DG	PG (optional)	CG	Independent
1	JTC/HDB precinct level involving new roads/drains, overhead bridge affecting green verge and trees	LTA, PUB, NParks	BCA	LTA, BCA, PUB, NParks	
2	LTA at-grade road construction/ viaduct by LTA, affecting green verge & drains/sewers more than 1.5m deep	PUB, NParks	BCA	PUB, BCA, NParks	-
3	PUB construction of drains within railway protection zone, affecting green verge, less than 1.5m depth	NParks, LTA Rails	LTA Rails	LTA Rails, NParks	-
4	LTA aboveground railway viaduct affecting some existing drains & green verge/trees within 70m of residential development	PUB, NEA, NPARKS	BCA	PUB, BCA, NEA, NParks	Agency-specific requirements e.g. NEA noise assessment
5	LTA cut and cover road tunnel affecting green verge requiring diversion of sewer > 1.5m deep	NParks, PUB	BCA	PUB, BCA, SCDF, NParks	-
6a	LTA underground rail bored tunnel/ common service tunnels within road reserve affecting green verge & trees	NParks	-	BCA, SCDF, NParks	
6b	LTA underground rail bored tunnel/ common service tunnels within road reserve affecting existing sewer	PUB	-	BCA, SCDF, PUB	Agency-specific requirements e.g. performance-based FE
7	PUB DTSS affecting trees and existing sewer	PUB, NParks	-	BCA, NParks	

-----  
**End of Infrastructure Works**  
 -----

# SECTION 4

## BIM Data Representation (IFC-SG) and Modelling Good Practice

## 4 BIM Data Representation (IFC-SG) and Modelling Good Practice

	Page
 <b>IFC-SG Model Preparation</b>	
• Preparing Models for Submission (General)	191
• Multi-Disciplinary Coordination	194
• Preparing Models for Submission	
○ Revit	197
○ Archicad	201
○ Tekla	206
○ OpenBuildings Designer	212
• 3 <sup>rd</sup> Party Application(s) to help with Preparation of IFC-SG Models	
○ IFC-SG Validator	216
○ DiRoots	219
• List of Recommended IFC Viewers	222
• Model Quality Quick Checklist	223
 <b>BIM Data Representation (IFC-SG)</b>	
• Glossary of “Identified Components”	225
• Modelling IFC-SG for BCA Structural Submission	227
• Modelling IFC-SG for SCDF Submission	228

## Preparing Models for Submission (General)

### ► Model Size

**Each model should not exceed 800 MB, and be submitted by parts (i.e. 1 block per file). If a part model exceeds 800MB, the part model should be split into smaller files. Files compiled in zip folders are not accepted.**

For huge developments that need to arrange their projects into different packages, please carry out a pre-submission consultation to seek agencies' concurrence for the proposal.

To help all project members understand the timing and delivery of data for every CORENET X submission, it is important to define the submission preparation and delivery details in the BIM Execution Plan. For more information, please refer to the BIM Essential Guide for BIM Execution Plan [here](#).

### ► Setting up Project Information

The Project Title, Address, QP Name & Professional Registration Number, and if applicable, Name & Professional Registration Number of Specialist QPs will be provided on the CORENET X Portal.

### ► Modelling in IFC-SG

- Most of the IFC parameter requirements are based on the international IFC 4 standards. A set of IFC-SG standards was developed to address specific regulatory requirements in Singapore that currently cannot be found in the international IFC standards.
- There are also IFC-SG parameters that had been defined & standardized to incorporate the current 2D drawings information and embedded in 3D models.
- A complete set of IFC-SG model shall consist of elements as described in this section of this COP. For example, a structural model can comprise of the following :
  - Piles
  - Footings / Pilecaps
  - Beams
  - Columns
  - Walls
  - Slabs
  - Staircases
  - Boreholes
- Industry practitioners shall use the [IFC-SG Resource Kit](#) to convert Native BIM models into IFC-SG models and verify no data loss occurred during the exporting.
- Details can be represented in 2D to supplement the IFC-SG model, such as:
  - Irregular pilecaps, raft foundation, slab elements, household shelter / storey shelter elements, transfer plates, precast elements, prestress elements, PPVC modules, steel connections.

Link:

[IFC-SG Resource Kit](#)

## Preparing Models for Submission (General)

### ▶ Reading the IFC-SG Mapping

- ✓ Know the element and its category
- ✓ What system it belongs to?
- ✓ What are the IFC Parameters that needs to map into it?
- ✓ To what Agency it will be submitted?

Agency	Identified Component	Identified parameters	Revit Representation	Archicad Representation	Domain	IFC Entities	IFC SubTypes (* = UNREPRESENTED)	Property Set	Property Name
PUB	Cold Water System	-	Piping Systems	MEP System	PLU	ifcDistributionSystem	*DOMESTICCOLDWATER	-	-
PUB	Bedding	Type	Generic Models	Model Element	ARC	ifcGeographicElement	*FOUNDATION	SGPset_GeographicElement	BeddingType
PUB	Manhole	Length	Plumbing Fixtures	Flow Equipment	PLU	ifcDistributionChamberElement	*MANHOLE	SGPset_DistributionChamberElementDimension	Length
PUB	Manhole	Width	Plumbing Fixtures	Flow Equipment	PLU	ifcDistributionChamberElement	*MANHOLE	SGPset_DistributionChamberElementDimension	Width
PUB	Manhole	Depth	Plumbing Fixtures	Flow Equipment	PLU	ifcDistributionChamberElement	*MANHOLE	SGPset_DistributionChamberElementDimension	Depth
PUB	Sanitary System	-	Piping Systems	MEP System	PLU	ifcDistributionSystem	*SANITARY	-	-
PUB	Sanitary System	-	Piping Systems	MEP System	PLU	ifcDistributionSystem	*SANITARY	-	-
PUB	Inspection Chamber	Length	Plumbing Fixtures	Flow Equipment	PLU	ifcDistributionChamberElement	*INSPECTIONCHAMBER	SGPset_DistributionChamberElementDimension	Length
PUB	Inspection Chamber	Width	Plumbing Fixtures	Flow Equipment	PLU	ifcDistributionChamberElement	*INSPECTIONCHAMBER	SGPset_DistributionChamberElementDimension	Width
PUB	Inspection Chamber	Depth	Plumbing Fixtures	Flow Equipment	PLU	ifcDistributionChamberElement	*INSPECTIONCHAMBER	SGPset_DistributionChamberElementDimension	Depth
PUB	Grease Trap	Height	Plumbing Fixtures	Flow Equipment	PLU	ifcInterceptor	*GREASE	SGPset_InterceptorDimension	Height
PUB	Grease Trap	Width	Plumbing Fixtures	Flow Equipment	PLU	ifcInterceptor	*GREASE	SGPset_InterceptorDimension	Width
PUB	Grease Trap	Length	Plumbing Fixtures	Flow Equipment	PLU	ifcInterceptor	*GREASE	SGPset_InterceptorDimension	Length
PUB	Water Closet	-	Plumbing Fixtures	Pipe Flow Terminal	PLU	ifcSanitaryTerminal	*WATERCLOSET	-	-
PUB	Sanitary System	Gradient	Piping Systems	MEP System	PLU	ifcDistributionSystem	*SANITARY	SGPset_SystemDimension	Gradient
PUB	Sanitary System	Length	Piping Systems	MEP System	PLU	ifcDistributionSystem	*SANITARY	SGPset_SystemDimension	Length
PUB	Sanitary System	Diameter	Piping Systems	MEP System	PLU	ifcDistributionSystem	*SANITARY	SGPset_SystemDimension	Diameter
PUB	Sump Pump	Standby Pump	Mechanical Equipment	Flow Equipment	PLU	ifcPump	*SUMPUMP	SGPset_Pump	Standby
PUB	Sump Pump	Duty	Mechanical Equipment	Flow Equipment	PLU	ifcPump	*SUMPUMP	SGPset_Pump	Duty
PUB	Sump Pump	Capacity	Mechanical Equipment	Flow Equipment	PLU	ifcPump	*SUMPUMP	SGPset_Pump	Capacity
PUB	Oil Interceptor	Height	Plumbing Fixtures	Flow Equipment	PLU	ifcInterceptor	*OIL	SGPset_InterceptorDimension	Height
PUB	Oil Interceptor	Width	Plumbing Fixtures	Flow Equipment	PLU	ifcInterceptor	*OIL	SGPset_InterceptorDimension	Width

S4 – Fig 1: IFC-SG Mapping

### ▶ Setting up the Model

**Upgrading the current in-house BIM Template into CORENET X Template**

- ✓ Study the existing object properties
- ✓ Know the properties that needs to be edited in-line with the IFC Configurator

**Pull out the common properties and assign as the object type properties**

- ✓ To avoid re-entering of properties.
- ✓ To avoid duplication of property when exported into IFC

**Map the existing object library properties into configuration file**

- ✓ One-time process
- ✓ Can be used into the future projects
- ✓ Eliminate duplicated work and errors
- ✓ Standard IFC exports for all your projects

Link:  
[IFC-SG Resource Kit](#)



## Preparing Models for Submission (General)

### ► Examples of IFC-SG Parameters

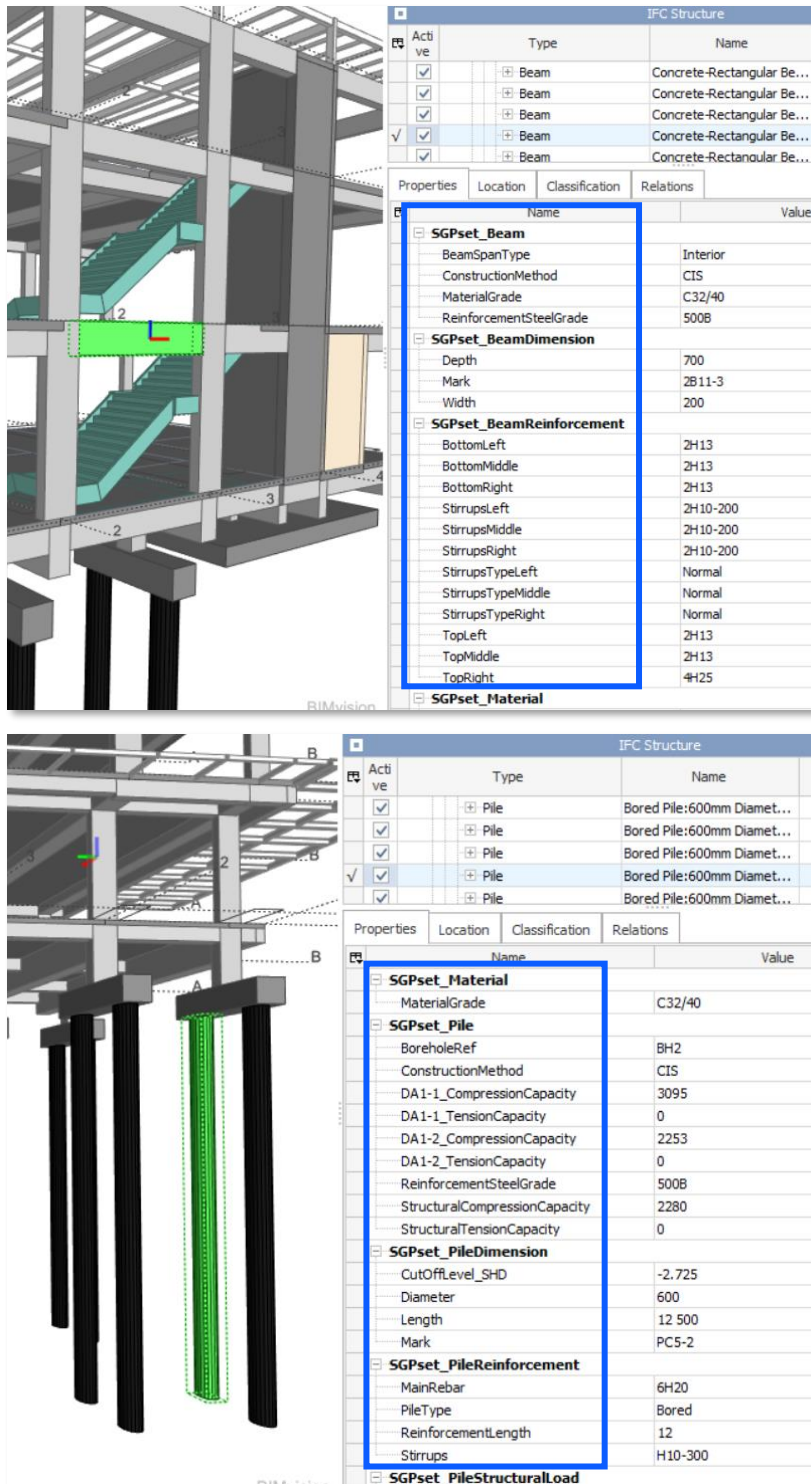

S4 – Fig 2 and 3: Example of IFC-SG Parameters

Link:  
[IFC-SG Resource Kit](#)

## Multi-Disciplinary Coordination

### ► Geo-Referencing

Models should be correctly geo-referenced and assigned real-world coordinates from the **Singapore SVY21 coordinate system (EPSG: 3414)** for Easting and Northing (x,y), including dimensions between grids. The layout of each model shall be presented in True North or real-world orientation, and the elevation levels or Height (z) of the model shall be set up based on the **Singapore Height Datum (SHD)**.

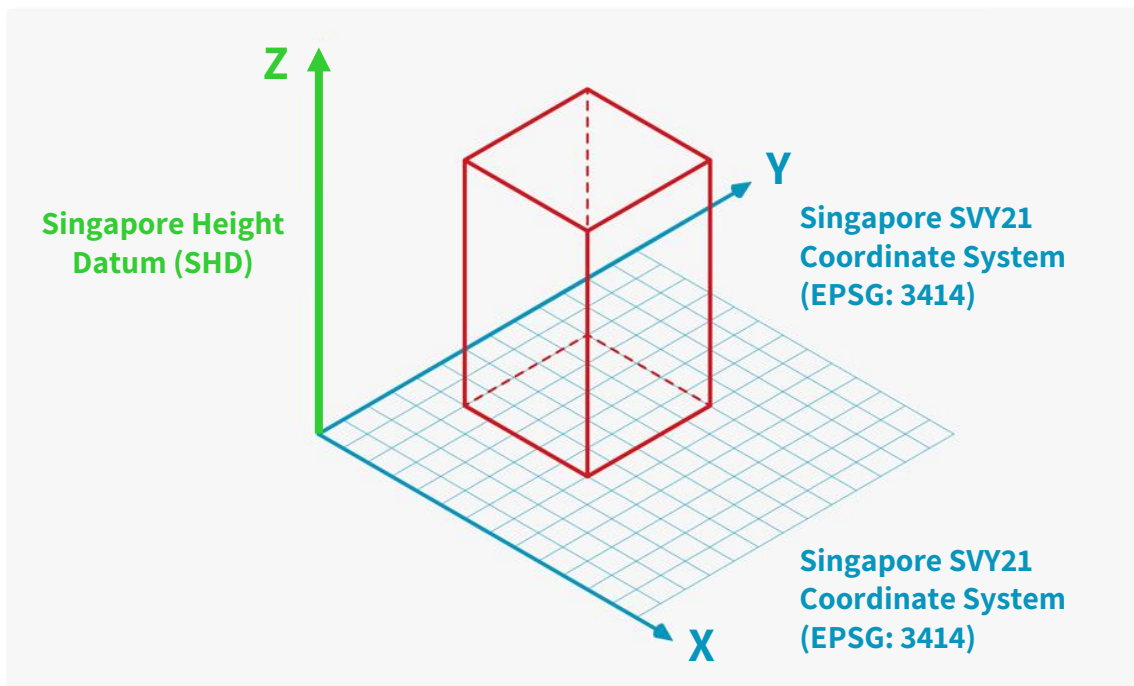

S4 – Fig 4: Geo-Referencing

The Singapore Institute of Surveyors and Valuers - Land Surveying Division has also come up with a video on geo-referencing, to explore how land surveyors and architects can work together to have more efficient workflow for future CORENET X submission.

For details and video demonstration on geo-referencing, please visit the CORENET X website [here](#).

#### Basic Geo-Referencing Checks

1. Open a third-party IFC viewer and select a point to check the coordinates.
2. Compare the coordinates with the expected real-life coordinates as specified by the project team.

#### Advanced Troubleshooting

1. Revit Users in the same project team with wrongly geo-referenced files:  
<https://www.autodesk.com/support/technical/article/caas/sfdcarticles/sfdcarticles/How-to-manage-Revit-linked-models-while-exporting-with-IFC-SG-schema.html>
2. Revit and Archicad Users in the same project team with wrongly geo-referenced files:  
<https://graphisoft.sharefile.com/public/share/web-s743946e891c34b9db46bf5c41f1ec42d>

## Multi-Disciplinary Coordination

### ► Alignment of Levels and Zones Across All Disciplines' Models

Besides discipline-specific models, it may be necessary to divide the project into separate parts, zones and levels for better management of the model sizes, especially for larger and more complex projects. Models from all disciplines MUST adopt a coordinated set of levels and zones and name the levels and zones identically.

- **Only multi-disciplinary models with identical names and “Z” values for levels will be processed by Processing Officers in the CORENET X Collaboration Platform.**
- **Check spot coordinates of platform levels in the models match inputs declared in the Submission Portal.**

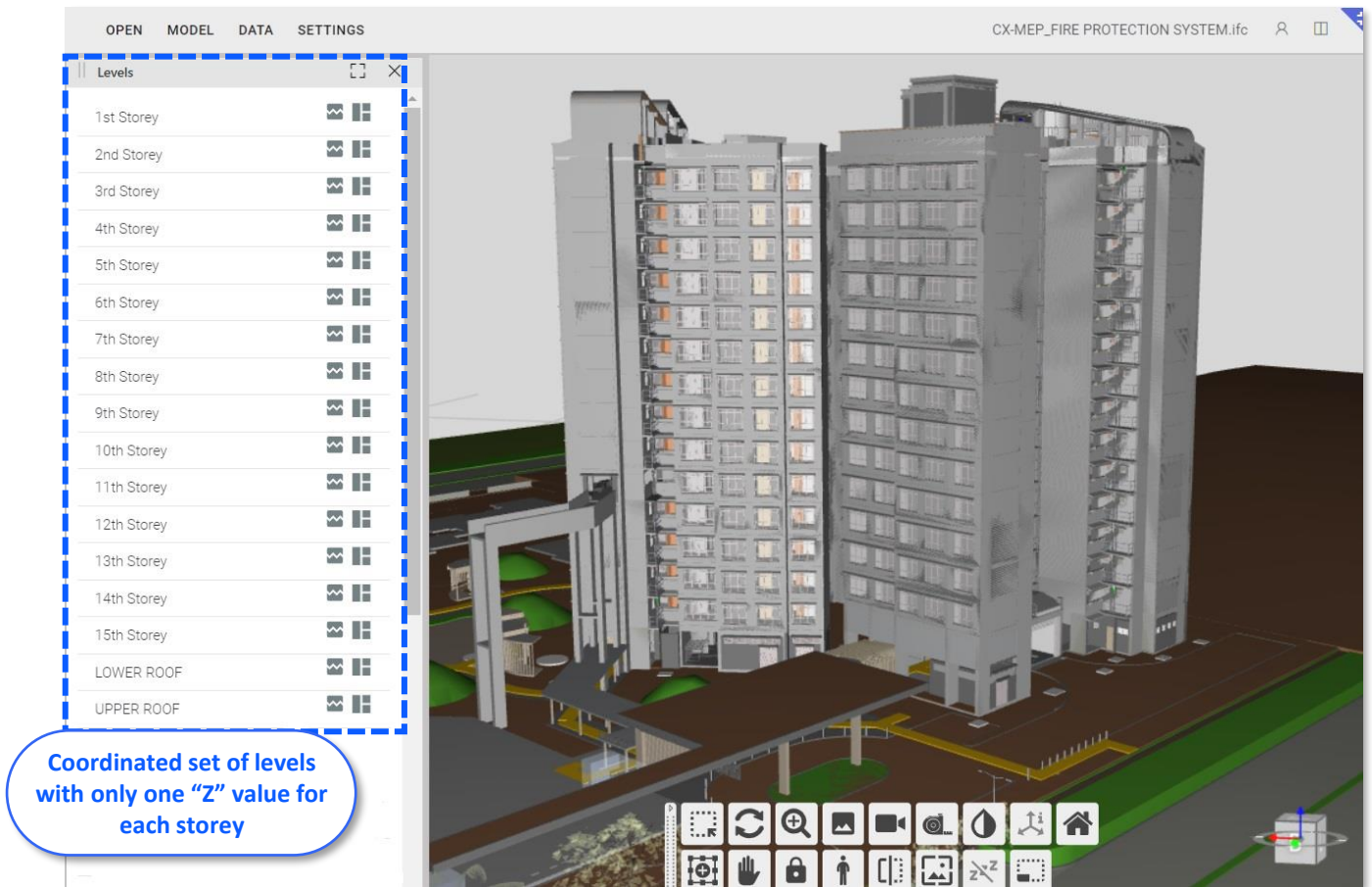

S4 – Fig 5: Multi-Disciplinary Coordination

# Multi-Disciplinary Coordination

## ► Clash Detection

The project team should ensure that in-principle, basic / key components from each discipline do not clash with one another, as indicated in the component clashes matrix below.

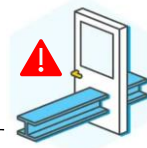

S4 – Fig 6 : Design Clash

Source: <https://www.bimcollab.com/en/products/bimcollab-zoom-b/>

For example, the Architectural Door should **not** have a design clash with the Structural Beam

		Architectural					Structural				
		Floor (IfcSlab)	Wall (IfcWall)	Ceiling (IfcCovering)	Door (IfcDoor)	Window (IfcWindow)	Structural Column (IfcColumn)	Structural Foundation (IfcPile, IfcFooting)	Structural Framing (IfcBeam)	Structural Wall (IfcWall)	Slab (IfcSlab)
Structural	Structural Column (IfcColumn)				1						
	Structural Foundations (IfcPile, IfcFooting)										
	Structural Framing (IfcBeam)		2		⚠						
	Structural Wall (IfcWall)				3						
	Slab (IfcSlab)										
	Generic Models (IfcBuildingElementProxy)										
MEP	Mechanical Equipment (IfcTank, IfcPump, IfcUnitaryEquipment)		4							8	
	Ducts (IfcDuctSegment)			5						9	
	Air Terminals (IfcAirTerminal)									10	
	Pipes (IfcPipeSegment)			6						⚠	
	Plumbing Fixtures (IfcSanitaryTerminal)									12	
	Cable Tray (IfcCableCarrierSegment)				7					13	
											11

S4 – Fig 7: Multi-Disciplinary Coordination

For example, the MEP Pipes should **not** have a design clash with the Structural Beam

S4 – Fig 8 : Design Clash

Photo credit: Clash Detection Projects | Tesla CAD UK

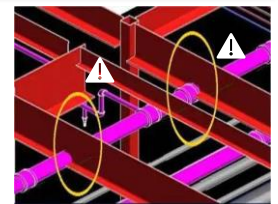

Note: Clash tolerance for specialist equipment such as an active chilled beam is acceptable.

# Preparing Models for Submission (Revit)

## Example using Revit Configuration File

### ► 1. Set your model into the agreed coordinates

- To place model into the correct location with Architectural, Civil & Structural, Mechanical & Electrical models.

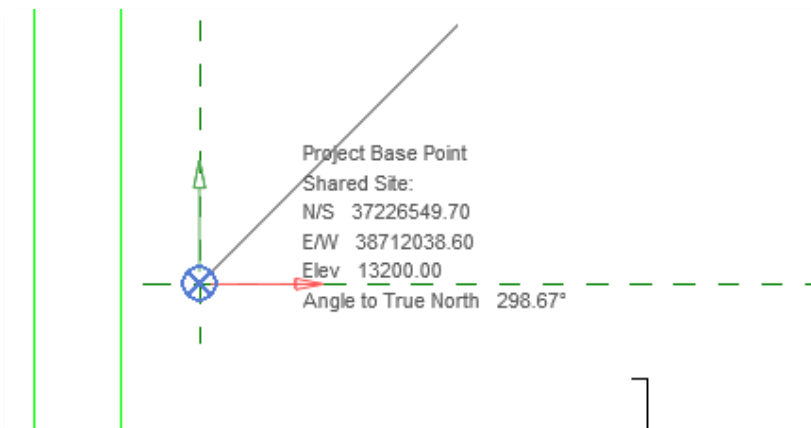

S4 – Fig9

### ► 2. Identify the IFC properties to be tagged into each element of your model

- Element's properties can be assigned while Modelling.

Agency	Identified Component	Domain	IFC4 Entities	IFC SubTypes (* = USERDEFINED)	Property Set	Property Name	Property Value	Property Unit	IFC4 Material Set
PUB	Cold Water System	PLU	IfcDistributionSystem	*DOMESTICCOLDWATER					
PUB	Bedding	ARC	IfcGeographicElement	*FOUNDATION	SGPset_GeographicElement	BeddingType	-	-	-
PUB	Manhole	PLU	IfcDistributionChamberElement	MANHOLE	SGPset_DistributionChamberElementDimension	Length	-	mm	-
PUB	Manhole	PLU	IfcDistributionChamberElement	MANHOLE	SGPset_DistributionChamberElementDimension	Width	-	mm	-
PUB	Manhole	PLU	IfcDistributionChamberElement	MANHOLE	SGPset_DistributionChamberElementDimension	Depth	-	mm	-

S4 – Fig10

Link:  
[IFC-SG Resource Kit](#)

# Preparing Models for Submission (Revit)

Example using Revit Configuration File

## 3. Set the Revit Workset

- To easily select the elements during IFC-SG Parameters mapping.
- To filter the views per Agency Submission.
- To reduce time when Exporting model in IFC format.
- To easily navigate when Modelling and model auditing.

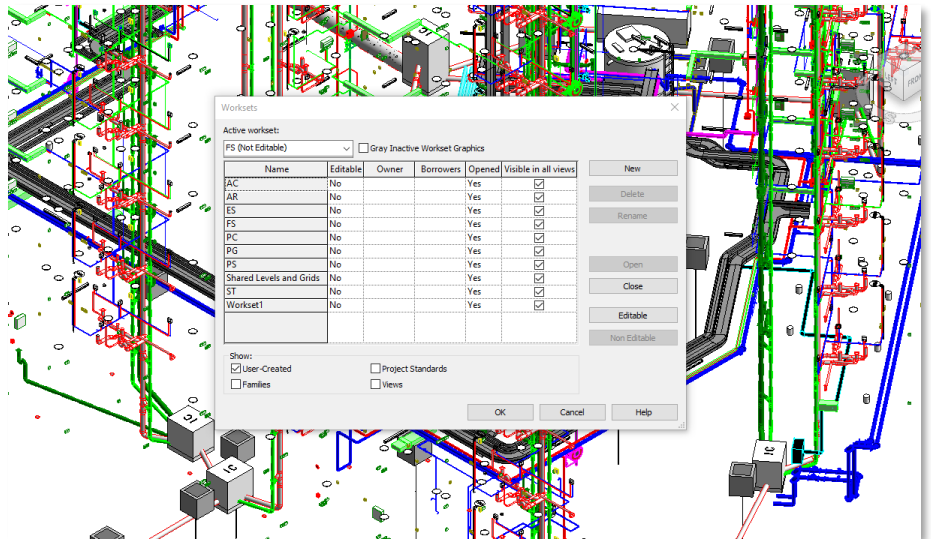

S4 – Fig 11

## 4. IFC-SG Mapping

- **Use BIM Interoperability Tools to assign IFC parameters**
- To avoid misspelled IFC parameters (misspelled parameters will not be exported).
- Faster than manual parameter key-in.
- Elements will be exported into the correct IFC category.

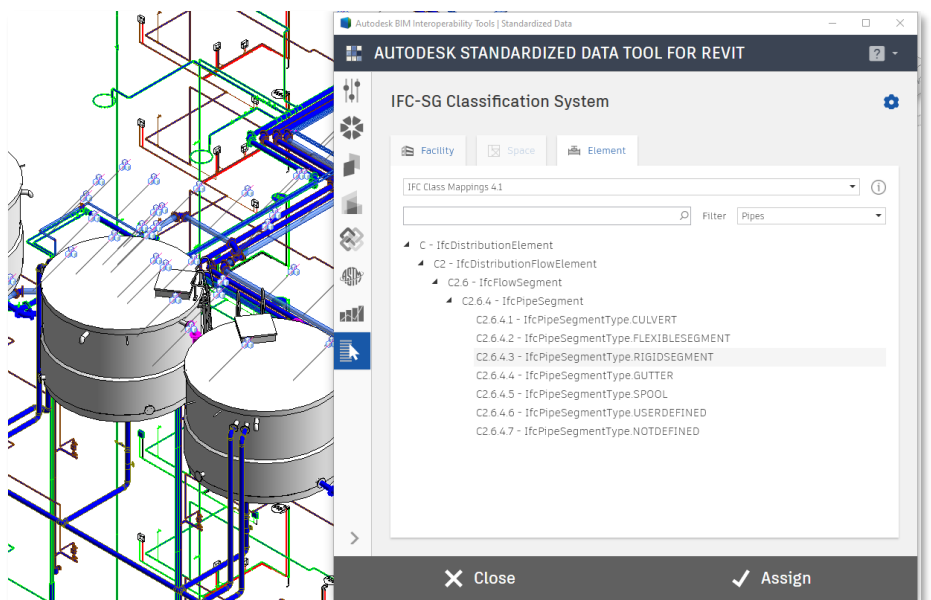

S4 – Fig 12

Link:  
[IFC-SG Resource Kit](#)

# Preparing Models for Submission (Revit)

## Example using Revit Configuration File

### ► From Revit Library

- Editing the Configuration File to Adapt In-house Company Properties

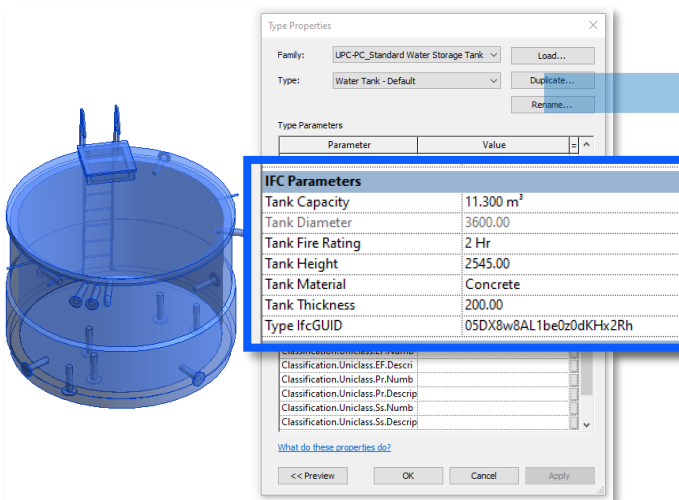

S4 - Fig 13: Revit Library

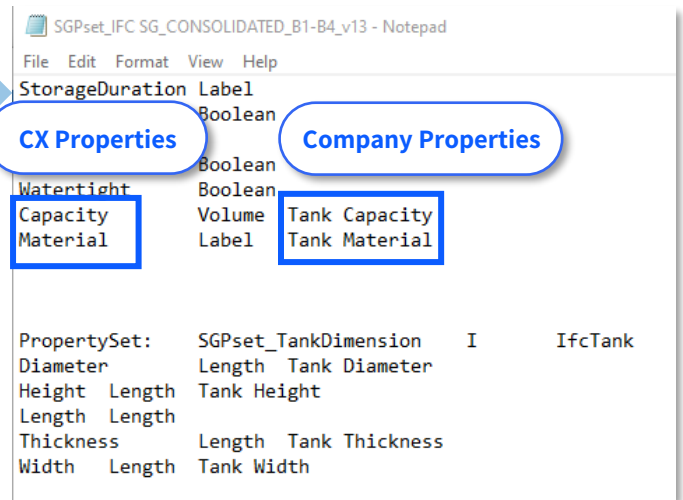

S4 - Fig 14: Configuration File

### ► From IFC Model

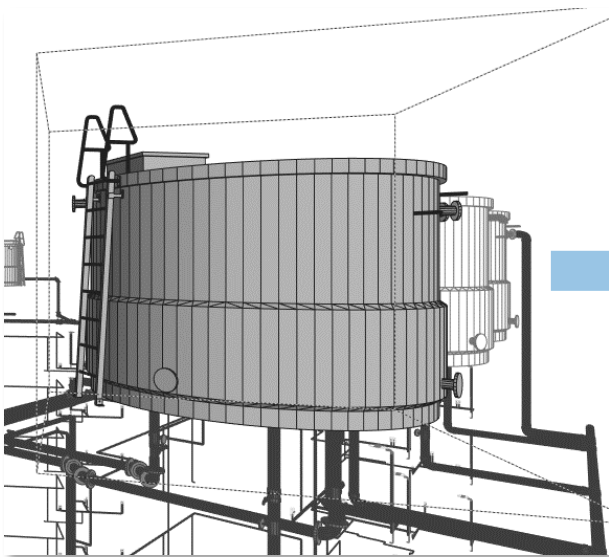

S4 - Fig 15

Properties	Location	Classification	Relations	Name	Value	Unit
<b>Element Specific</b>						
Guid				05DX8w8AL1be0z0dKHwvvp		
IfcEntity				IfcTank		
Name				UPC-PC_Standard Water Storage Tank:Water Tank - Default:2376892		
ObjectType				UPC-PC_Standard Water Storage Tank:Water Tank - Default		
PredefinedType				STORAGE		
Tag				2376892		
<b>Pset_EnvironmentalImpactIndicators</b>						
Reference				Water Tank - Default		
<b>Pset_TankTypeCommon</b>						
Reference				Water Tank - Default		
<b>SGPset_Tank</b>						
Capacity				11.3	m <sup>3</sup>	
IsPotable				Yes		
<b>SGPset_TankDimension</b>						
Diameter				3 600	mm	
Height				2 545	mm	
Thickness				200	mm	

S4 - Fig 16

Link:  
[IFC-SG Resource Kit](#)

## Top 3 Common Modelling Challenges and Solutions (Revit)

Example using Revit Configuration File

### ► Challenge 1

Challenge	Implications	Solutions
<b>Accidentally spelling IFC property wrongly</b>  e.g. ✓ IfcTank ✗ IfcTanl ✗ ifctank	➤ <b>Missing data in IFC</b> <ul style="list-style-type: none"> <li>IFC properties cannot be exported</li> <li>Existing in-house properties not mapped properly (to wrong IFC properties), thus also can't be exported</li> </ul>	✓ <b>Avoid manual typing where possible</b> <ul style="list-style-type: none"> <li>Use BIM Interoperability Tool, select from drop down list</li> <li>Copy Paste the information from IFC-SG Industry Mapping (.XLS file from GovTech)</li> </ul>

### ► Challenge 2

Challenge	Implications	Solutions
<b>Forgetting to update IFC after changes / modifications to model</b>	➤ <b>Missing data in IFC</b> <ul style="list-style-type: none"> <li>IFC properties cannot be exported</li> <li>Existing in-house properties not mapped properly (to wrong IFC properties), thus also can't be exported</li> </ul>	✓ <b>Check Mapping</b> <ul style="list-style-type: none"> <li>Redo the mapping</li> <li>Use Schedule to cross check if all elements were tagged properly.</li> </ul>
		✓ <b>Avoid manual typing where possible</b> <ul style="list-style-type: none"> <li>Use BIM Interoperability Tool, select from drop down list</li> <li>Copy Paste the information from IFC-SG Industry Mapping (.XLS file from GovTech)</li> </ul>

### ► Challenge 3

Challenge	Implications	Solutions
<b>Cannot export Revit linked files to a federated IFC (model with multiple link files)</b>  e.g. MEP sub-discipline models	➤ <b>Missing data in IFC</b> <ul style="list-style-type: none"> <li>Assigned systems will be lost</li> <li>IFC properties cannot be exported</li> <li>Existing in-house properties not mapped properly (to wrong IFC properties), thus also can't be exported</li> </ul>	✓ <b>Today</b> <ul style="list-style-type: none"> <li>Tag information after binding models</li> <li>Use Group Models instead of Binding</li> <li>Avoid binding if possible (i.e. export linked files one by one)</li> </ul>
		✓ <b>Future</b> <ul style="list-style-type: none"> <li>Through CORENET X community of practice, we have feedback to Autodesk to enable export of federated IFC</li> <li><b>Autodesk shared that this is part of the Revit Roadmap and will be included progressively in early 2023</b></li> </ul>



# Preparing Models for Submission (Archicad)

Example using Archicad Configuration File

## ► 1. Geo-reference the project

- To geo reference the project for Architectural, Civil & Structural, Mechanical & Electrical Model, refer [here](#).

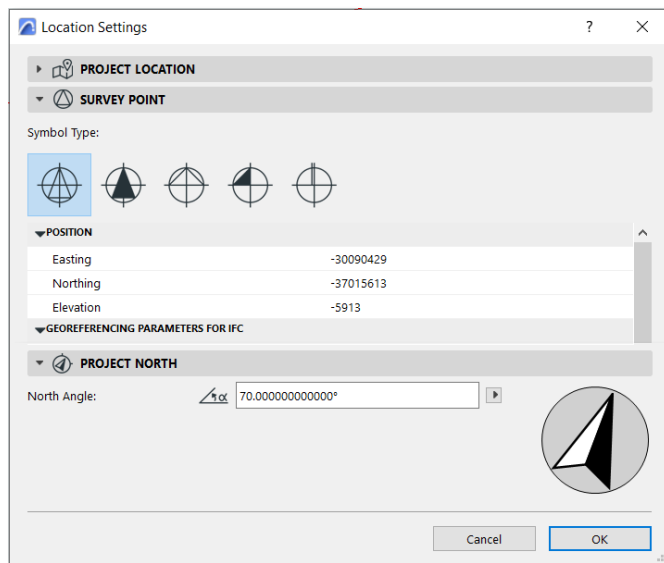

S4 – Fig 17

## ► 2. Identify the IFC properties to be tagged into each element in your model

- Element's properties can be assigned while modeling. Note: some parameters can be auto-filled using expressions.

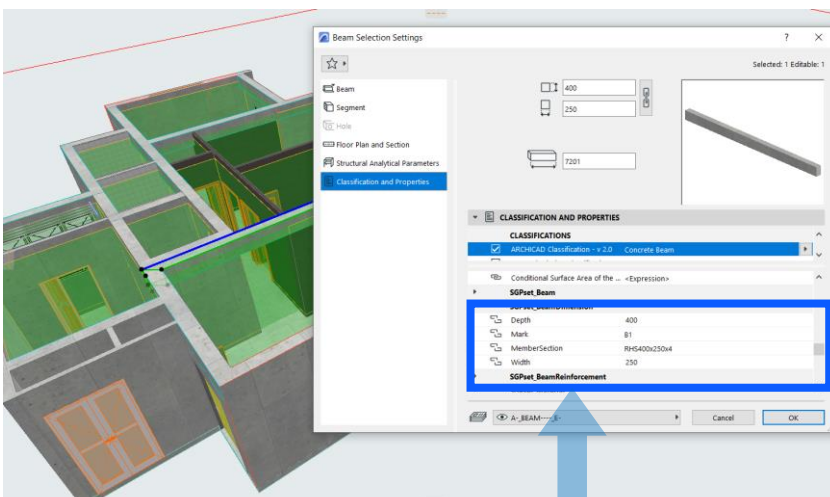

Agency	Identified Component	Identified parameters	Archicad Representation	Discipline	IFC4 Entities	IFC Sub Types (* = USERDEFINED)	Property Set	Property Name	Property Type	Property Unit	IFC4 Material Set
BCA	Beam	Depth	Beam	STR	IfcBeam	Need not specify	SGPset_BeamDimension	Depth	length	mm	N.A
BCA	Beam	Mark	Beam	STR	IfcBeam	Need not specify	SGPset_BeamDimension	Mark	label	N.A	N.A
BCA	Beam	Member Section	Beam	STR	IfcBeam	Need not specify	SGPset_BeamDimension	MemberSection	label	N.A	N.A
BCA	Beam	Width	Beam	STR	IfcBeam	Need not specify	SGPset_BeamDimension	Width	length	mm	N.A

S4 – Fig 18

Link:  
[IFC-SG Resource Kit](#)

## Preparing Models for Submission (Archicad)

Example using Archicad Configuration File

### ► 3. Set the View for Export from Navigator

- To easily view and select the elements while modelling.
- To easily navigate while modeling and checking.
- To filter the views as per Agency Submission.
- To easily export only elements visible on the current view.

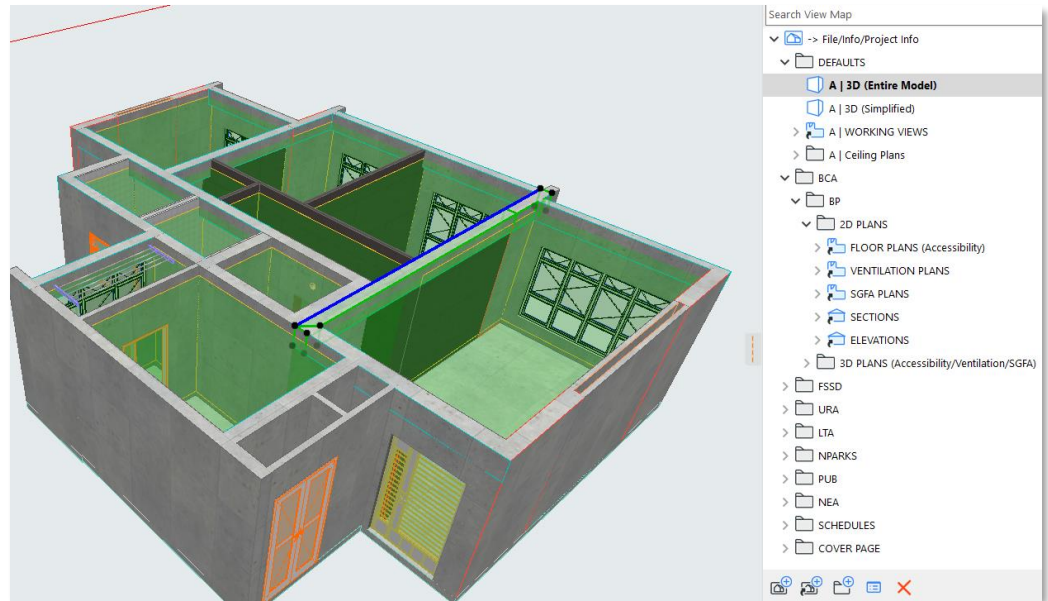

S4 – Fig 19

### ► 4. Model Verification using IFC Project Manager

- IFC Project Manager for Model Verification before export
- Assign or edit IFC-SG Property Values.
- Create custom IFC Property, Groups (Zones, Systems)

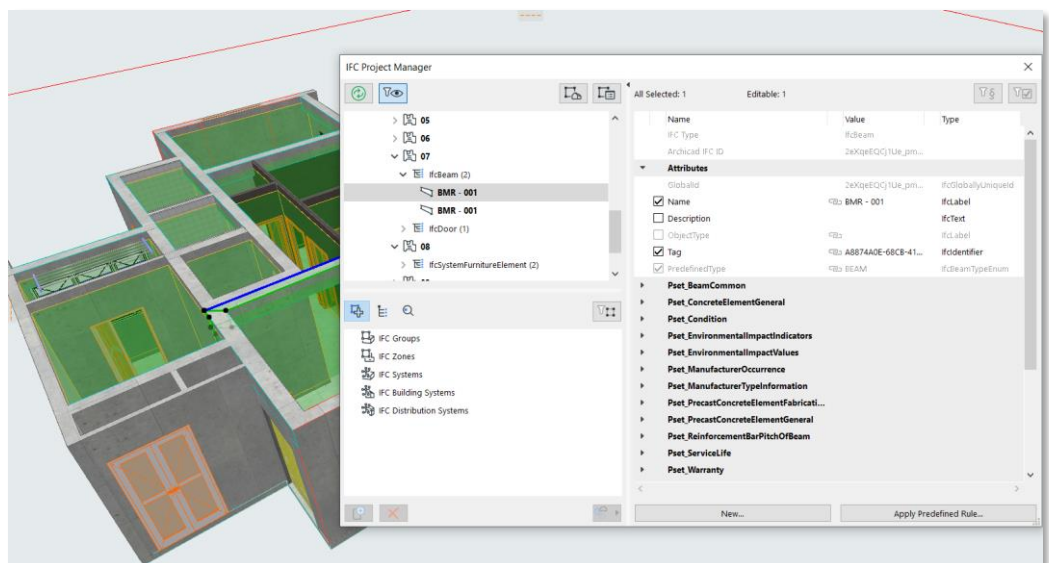

S4 – Fig 20

Link:  
[IFC-SG Resource Kit](#)

# Preparing Models for Submission (Archicad)

Example using Archicad Configuration File

## ► 5. IFC-SG Property Mapping

- IFC-SG Properties are already mapped in the IFC-SG Export Translator.

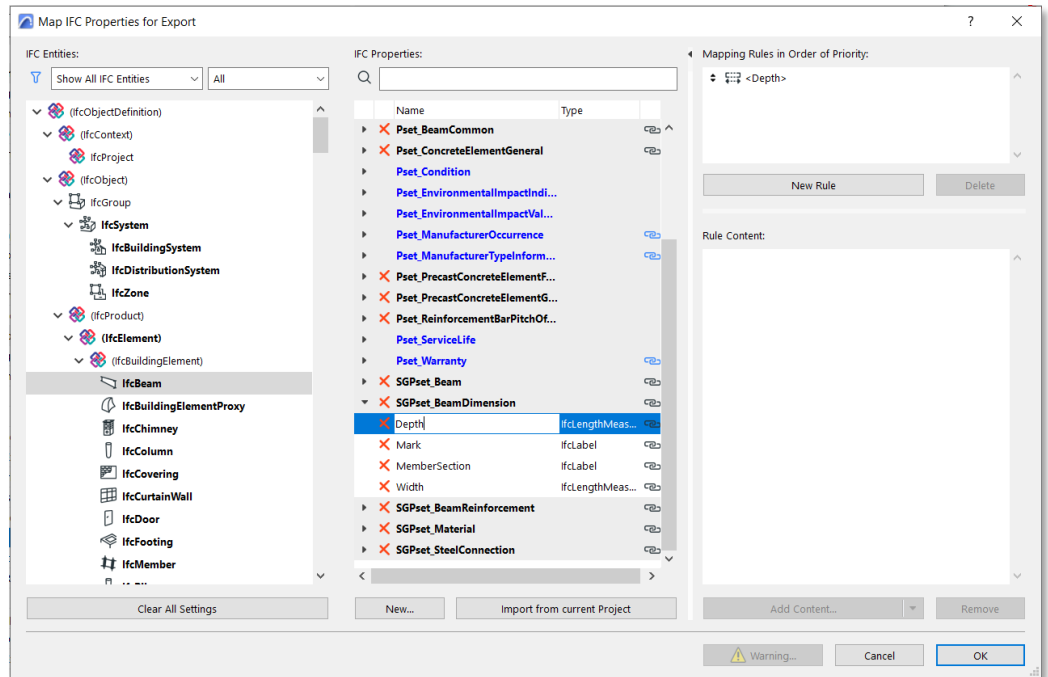

S4 – Fig 21

## ► 6. Export IFC Model

- Export visible elements (in all stories)
- Make sure to chose IFC-SG Translator
- Verify the IFC model in BIM Vision or Solibri Anywhere after exporting.

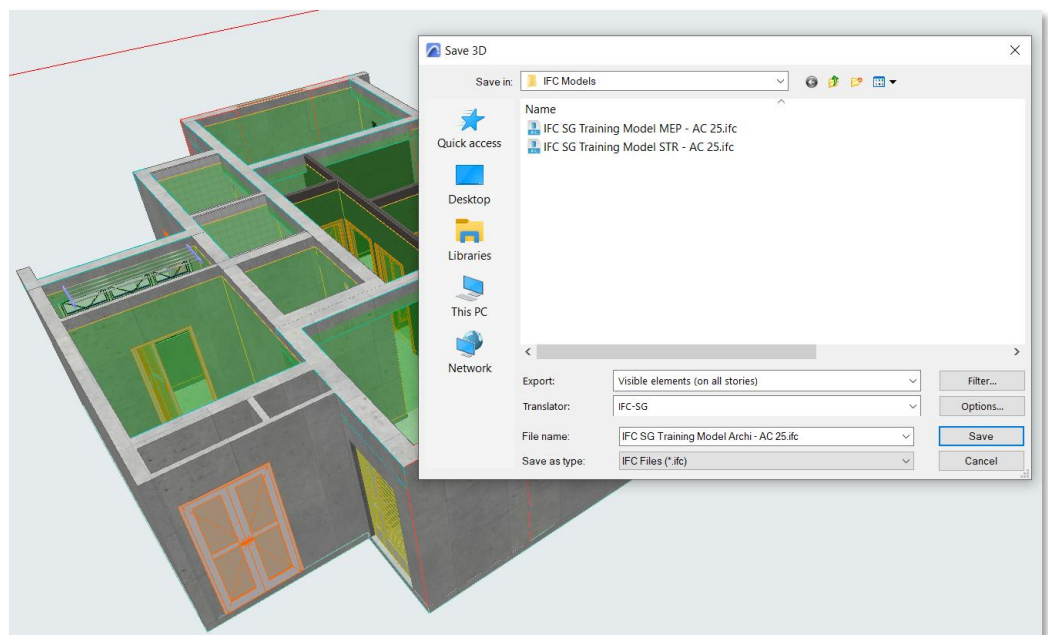

S4 – Fig 22

Link:  
[IFC-SG Resource Kit](#)

## Top 3 Modelling Tips (Archicad)

Example using Archicad Configuration File

### ► Tip 1

Scenario	Implications	Solutions
Updating latest IFC-SG requirements in Archicad project.	<p>➤ <b>Missing data in IFC</b></p> <ul style="list-style-type: none"> <li>Not importing latest IFC-SG requirements (config files) into the project.</li> </ul>	<p>✓ <b>Import latest config files</b></p> <p>For ongoing project:</p> <ul style="list-style-type: none"> <li>If expressions are used in properties, make sure to <a href="#">export those properties definitions (xml files)</a>.</li> <li>If IFC-SG parameters are populated with values, make sure to export those element parameters (<a href="#">Excel export from Schedules</a>)</li> <li>Import the config files using the <a href="#">Import IFC-SG Classifications and Properties</a> add-on.</li> <li>Import (merge) the properties xml exported in step 1.</li> <li>Import the excel schedule exported in step 2.</li> </ul> <p>For new project:</p> <ul style="list-style-type: none"> <li>Import the config files using the <a href="#">Import IFC-SG Classifications and Properties</a> add-on.</li> </ul>

### ► Tip 2

Scenario	Implications	Solutions
Update IFC-SG parameter values of non geometric entities.  E.g.: IfcSite, IfcBuilding, IfcStorey	<p>➤ <b>Missing data in IFC</b></p> <ul style="list-style-type: none"> <li>Missing values of IFC-SG Parameters of Non geometric entities.</li> </ul>	<p>✓ <b>Import latest config files</b></p> <ul style="list-style-type: none"> <li>Use IFC Project Manager to update the values of IFC-SG Parameters of spatial entities like IfcSite, IfcBuilding, IfcStorey</li> </ul>

### ► Tip 3

Scenario	Implications	Solutions
Update parameter values of IFC Systems, Groups, Building Systems, Distribution Systems	<p>➤ <b>Missing data in IFC</b></p> <ul style="list-style-type: none"> <li>Missing values of IFC-SG Parameters of IFC Systems, Groups, Building Systems, Distribution Systems</li> </ul>	<p>✓ <b>Import latest config files</b></p> <ul style="list-style-type: none"> <li>Use IFC Project Manager to update the values of IFC-SG Parameters of IFC Systems, Groups, Building Systems, Distribution Systems.</li> </ul>

# Preparing Models for Submission (Tekla)

## Example using Tekla Configuration File

### ► 1. Geo-reference the project

- To place model relative to the selected project base point using the coordinate system values.

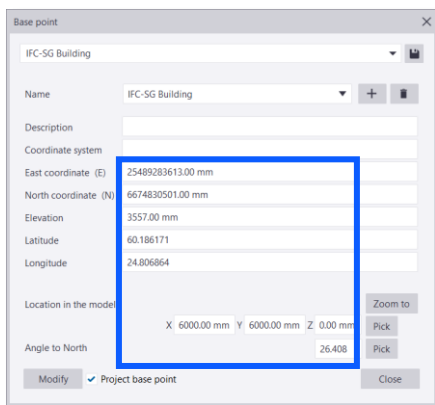

S4 – Fig 23 :  
Example of Base Point Dialog Box

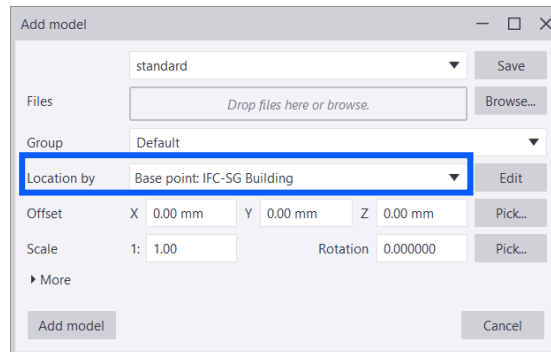

S4 – Fig 24 :  
Example of Add model Dialog Box

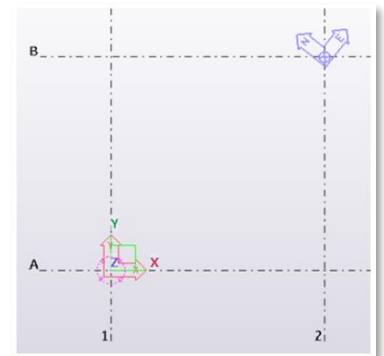

S4 – Fig 25 :  
Example of Base Point on model

### ► 2. Identify the IFC properties to be tagged into each element of your model

- Element's properties are automatically populated as measure type while modeling, no need to fill-in manually.

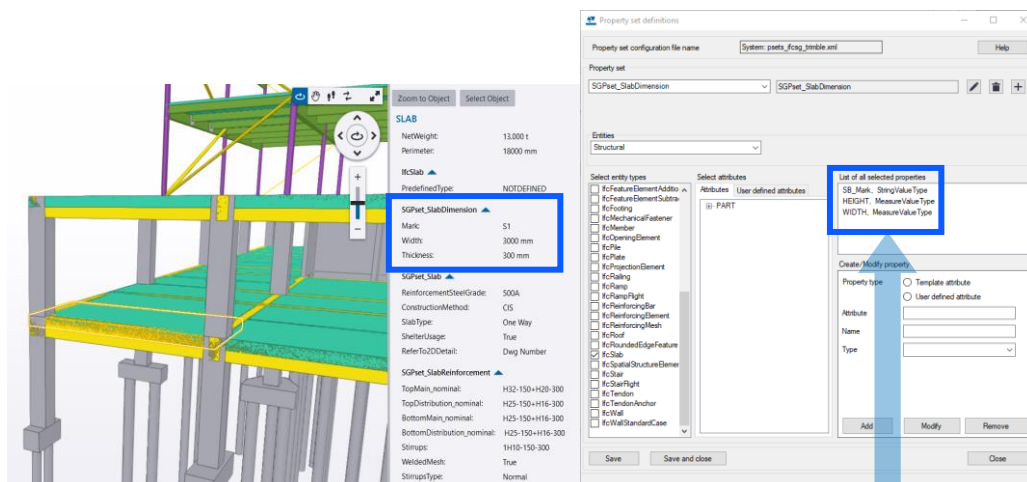

Discipline	IFC4 Entities	IFC Sub Types (* = USERDEFINED)	Property Set	Property Name	Property Type	Property Unit	IFC4 Material Set
STR	IfcSlab	Need not specify	SGPset_Slab	SlabType	Label	N.A	N.A
STR	IfcSlab	Need not specify	SGPset_Slab	ConstructionMethod	Label	N.A	N.A
STR	IfcSlab	Need not specify	SGPset_Slab	ReferTo2DDetail	Label	N.A	N.A
STR	IfcSlab	Need not specify	SGPset_Slab	ReinforcementSteelGrade	Label	N.A	N.A
STR	IfcSlab	Need not specify	SGPset_Slab	ShelterUsage	Boolean	N.A	N.A
STR	IfcSlab	Need not specify	SGPset_SlabDimension	Mark	Label	N.A	N.A
STR	IfcSlab	Need not specify	SGPset_SlabDimension	Thickness	Length	mm	N.A
STR	IfcSlab	Need not specify	SGPset_SlabReinforcement	WeldedMesh	Boolean	N.A	N.A
STR	IfcSlab	Need not specify	SGPset_SlabReinforcement	BottomDistribution_nominal	Label	N.A	N.A
STR	IfcSlab	Need not specify	SGPset_SlabReinforcement	BottomMain_nominal	Label	N.A	N.A
STR	IfcSlab	Need not specify	SGPset_SlabReinforcement	TopDistribution_nominal	Label	N.A	N.A
STR	IfcSlab	Need not specify	SGPset_SlabReinforcement	TopMain_nominal	Label	N.A	N.A
STR	IfcSlab	Need not specify	SGPset_SlabReinforcement	Stirrups	Label	N.A	N.A
STR	IfcSlab	Need not specify	SGPset_SlabReinforcement	StirrupsType	Label	N.A	N.A

S4 – Fig 26

# Preparing Models for Submission (Tekla)

Example using Tekla Configuration File

## 3. IFC-SG Mapping

- Use IFC Data Extractor (Auto-Filler) Tool to assign IFC parameters
- Faster than keying in manual parameters

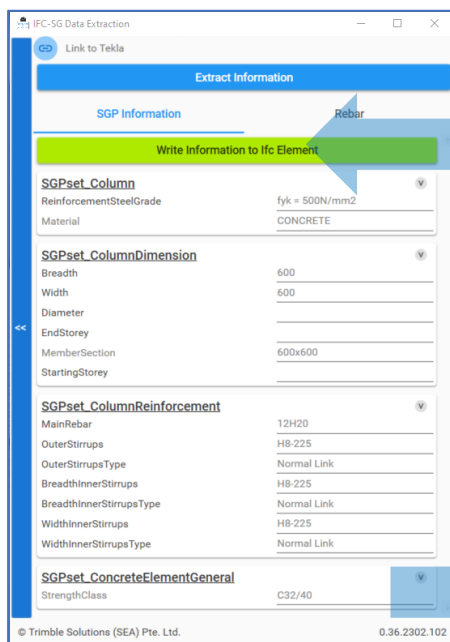

S4 – Fig 27

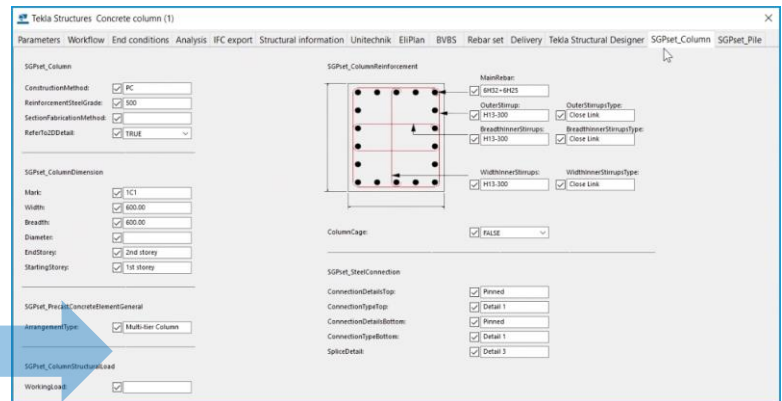
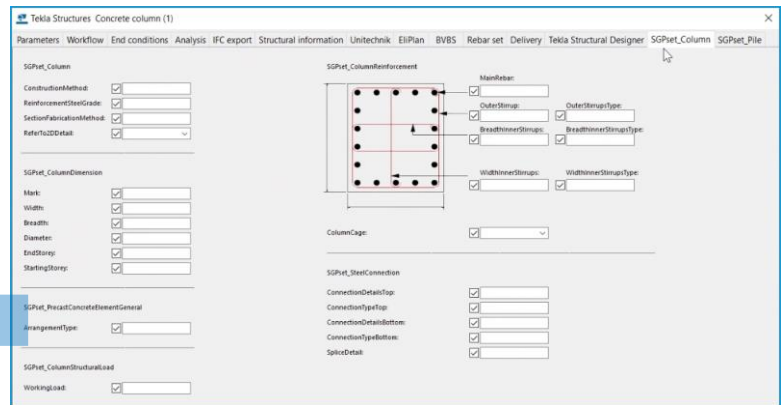

S4 – Fig 28 & 29

## 4. IFC Export Setup

- To simplify the process of choosing elements while mapping IFC-SG parameters
- To streamline the process of exporting a mode in IFC format and save time

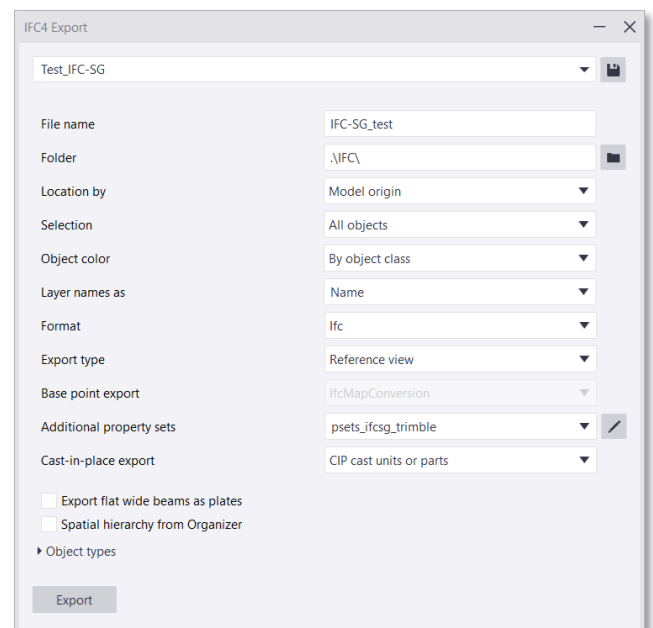

S4 – Fig 30

# Preparing Models for Submission (Tekla)

Example using Tekla Configuration File

## ► Examples of IFC-SG Parameters

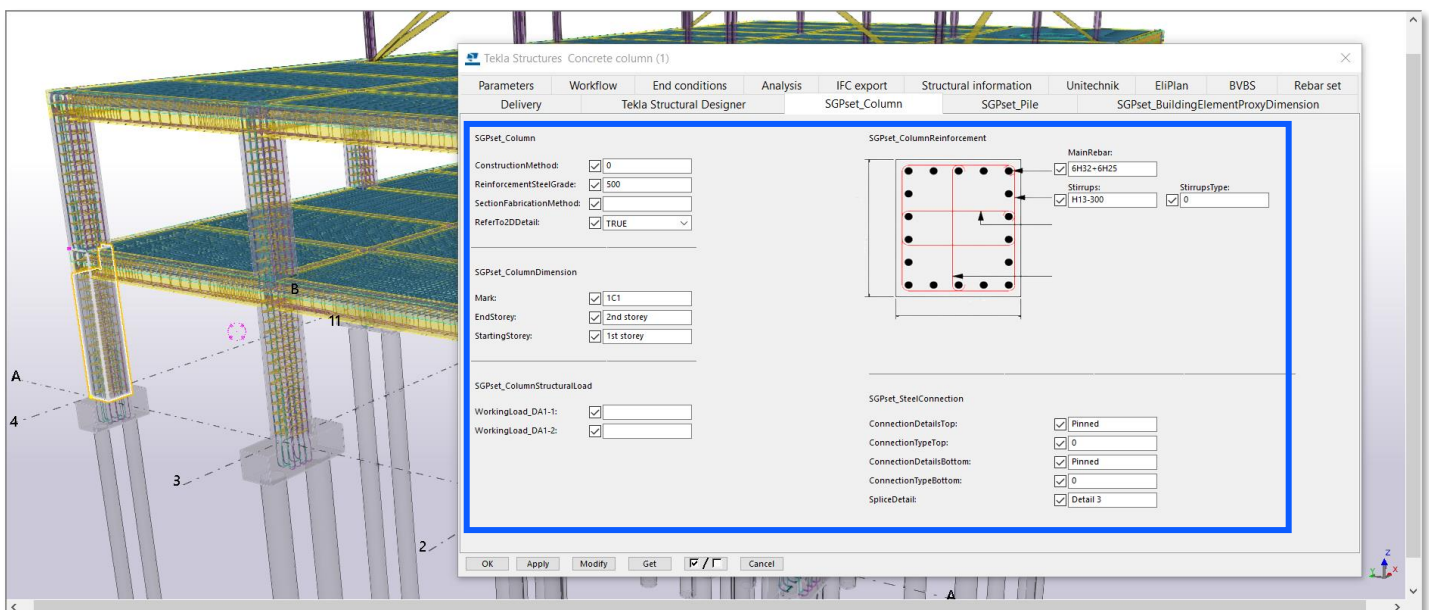
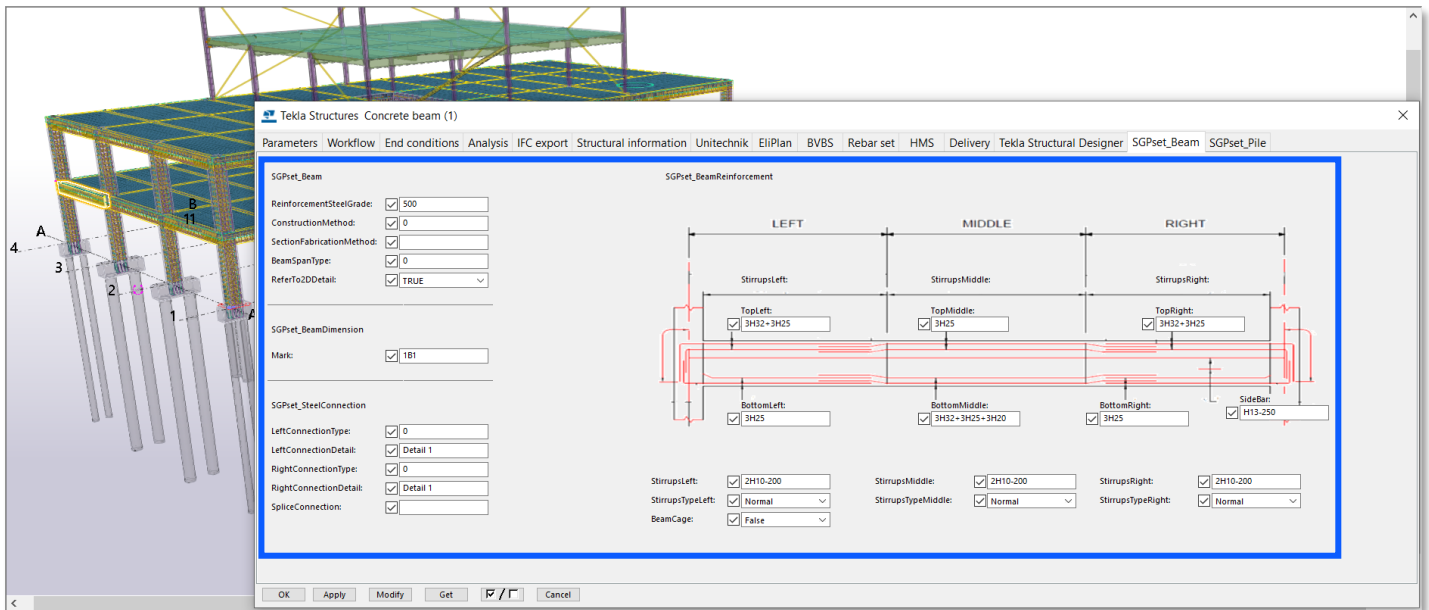

S4 – Fig 31 & 32 : Example of IFC-SG Parameters

# Preparing Models for Submission (Tekla)

Example using Tekla Configuration File

## ► From Tekla User-Defined Attribute (UDA) Parameters

- Editing configuration file to adapt in-house properties

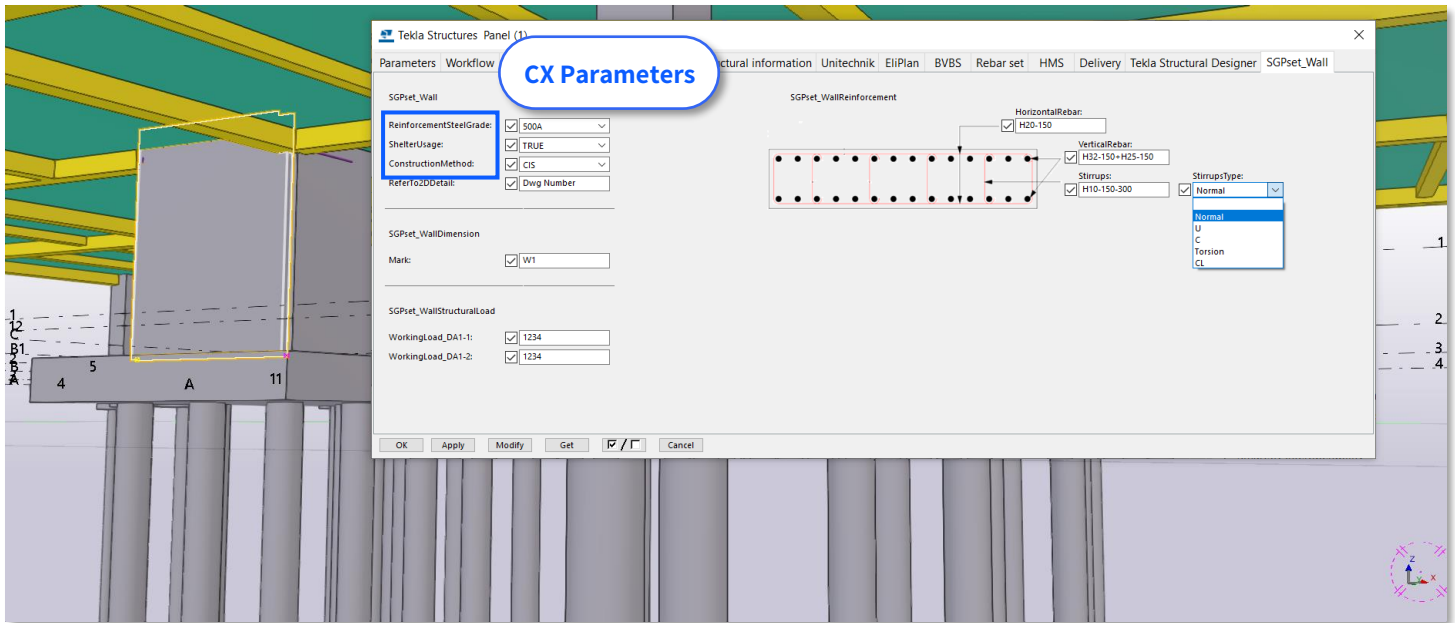

```

objects_ifsg_trimble.inp - Notepad
File Edit Format View Help
/** SGPset_Wall */
attribute("", "SGPset_Wall", label, "%s", none, none, "0", "0", 22, 17)

attribute("", "ReinforcementSteelGrade:", label, "%s", none, none, "0", "0", 22, 60)
attribute("WA_ReinforcementSt", "", option, "%s", No, none, "0.0", "0.0", 250, 60, 160)
{
    value("", 2)
    value("500A", 0)
    value("500B", 0)
    value("500C", 0)
    value("600A", 0)
    value("600B", 0)
    value("600C", 0)
}

attribute("", "ShelterUsage:", label, "%s", none, none, "0", "0", 22, 90)
/* MODIFIED */
attribute("WA_ShelterUsage", "", option, "%s", No, none, "0.0", "0.0", 250, 90, 160)
{
    value("", 2)
    value("FALSE", 0)
    value("TRUE", 0)
}

/* MODIFIED */
attribute("", "ConstructionMethod:", label, "%s", none, none, "0", "0", 22, 120)
attribute("WA_ConstructionMet", "", option, "%s", No, none, "0.0", "0.0", 250, 120, 160)
{
    value("", 2)
    value("CIS", 0)
    value("PC", 0)
    value("PT (Pre)", 0)
    value("PT (Post)", 0)
    value("PF", 0)
    value("PPVC", 0)
}
    
```

Company Parameters

S4 – Fig 33 & 34



# Preparing Models for Submission (Tekla)

Example using Tekla Configuration File

## ► Sample (Large) Tekla Structure Model and File Size

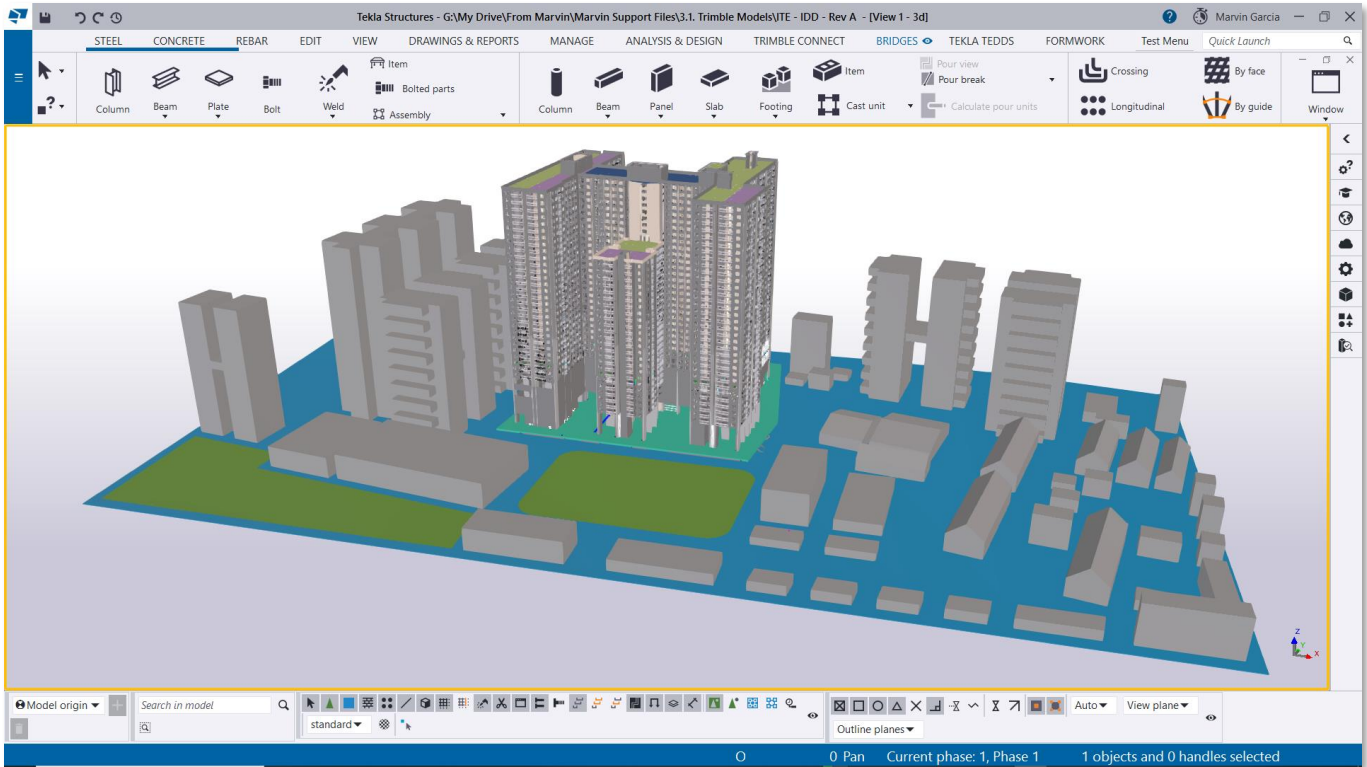

S4 – Fig 35 : Example of Large Tekla Model

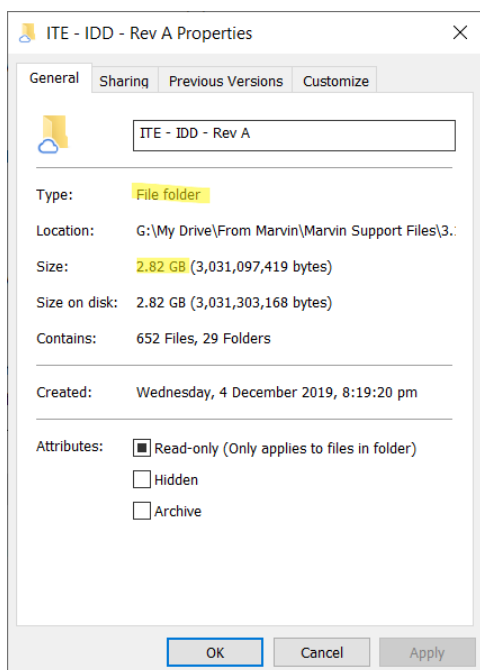

S4 – Fig 36 : Example of a Tekla Model folder

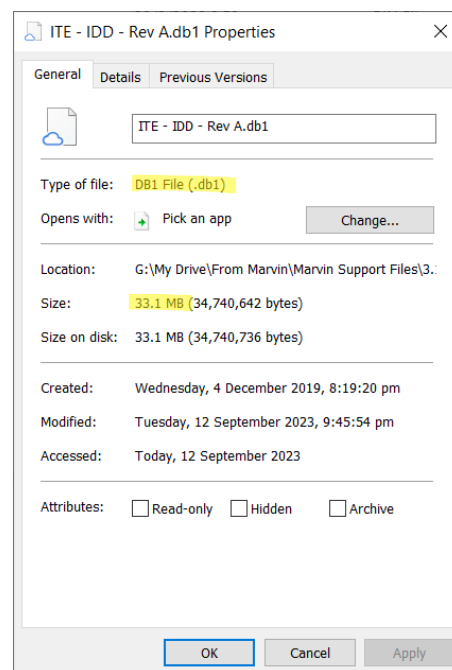

S4 – Fig 37 : Example of a Tekla model database \*.db1

# Preparing Models for Submission (Tekla)

Example using Tekla Configuration File

## ► From IFC Model Property Set (SGPset)

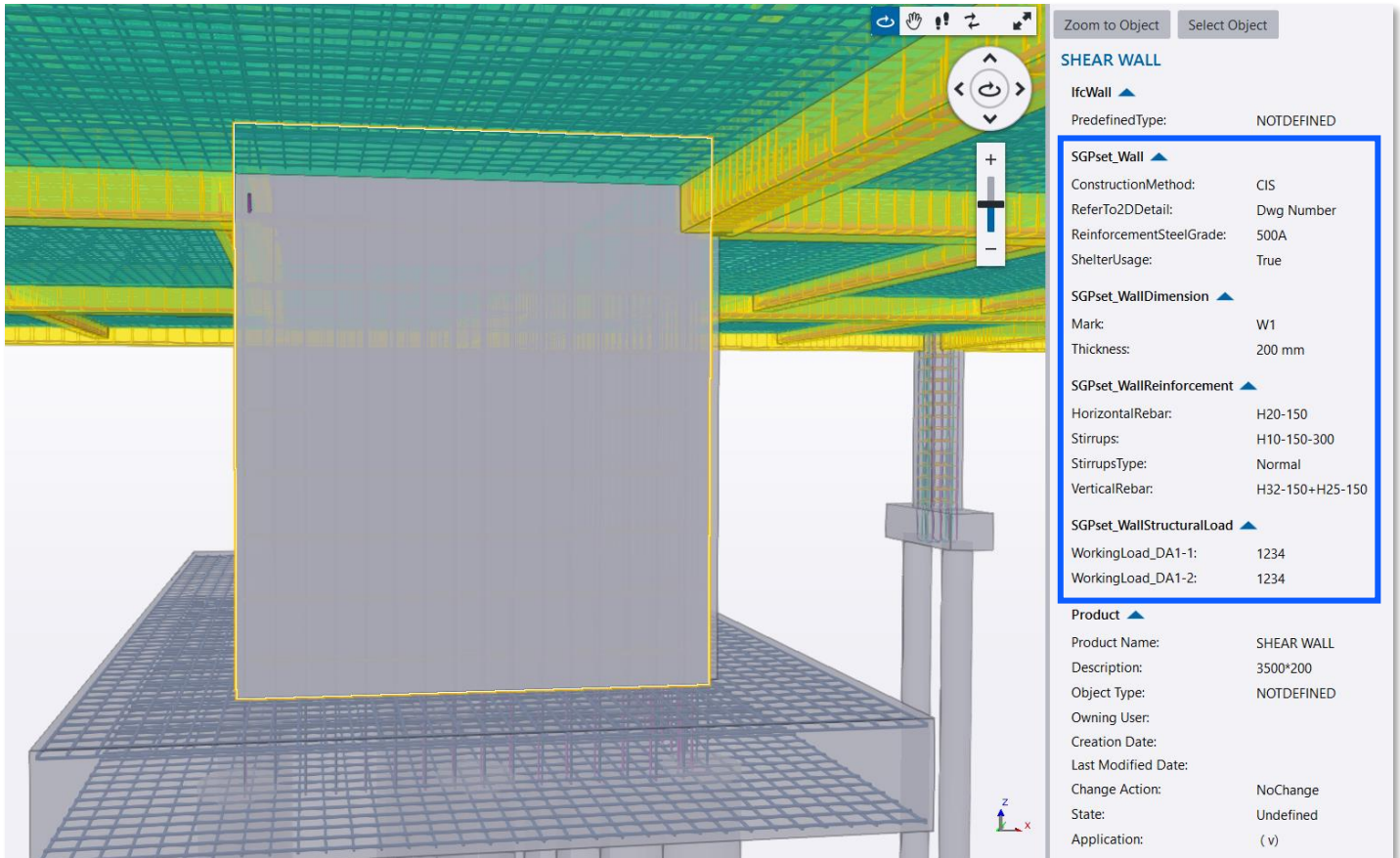

S4 - Fig 38

## Top 3 Common Modelling Challenges and Solutions (Tekla)

Example using Tekla Configuration File

### ► Challenge 1

Challenge	Implications	Solutions
Forgetting to update the definitions of user-defined attribute after modifying the objects.inp	➤ <b>Incorrect data in IFC</b>	✓ <b>Avoid modifying the label unless necessary</b>
	<ul style="list-style-type: none"> <li>Previously set in-house properties weren't correctly matched with the right IFC properties</li> </ul>	<ul style="list-style-type: none"> <li>Use Diagnose &amp; Repair to detect and repair the incorrect UDA value types</li> <li>Do not modify unless an experienced user</li> </ul>

### ► Challenge 2

Challenge	Implications	Solutions
Forgetting to update IFC after changes / modifications to model	➤ <b>Missing or incorrect data in IFC</b>	✓ <b>Re-Export IFC</b>
	<ul style="list-style-type: none"> <li>Previously set in-house properties weren't correctly matched with the right IFC properties</li> </ul>	<ul style="list-style-type: none"> <li>Load the pre-defined setting for IFC export</li> <li>Use filter when selecting an object if not meant for all objects</li> </ul>

### ► Challenge 3

Challenge	Implications	Solutions
Forgetting to set Subtype (IFC4)	➤ <b>Missing or incorrect data in IFC</b>	✓ <b>Check IFC Subtype (IFC4)</b>
	<ul style="list-style-type: none"> <li>Previously set in-house properties weren't correctly matched with the right IFC properties</li> </ul>	<ul style="list-style-type: none"> <li>Set and define the needed IFC Subtype</li> <li>Load the pre-defined types of the entity in the list of available drop-down option</li> </ul>

Link:

[IFC-SG Resource Kit](#)

# Preparing Models for Submission (OpenBuildings Designer)

Example using OpenBuildings Designer Configuration File

## ► 1. Geo-coordinate your project.

- To geo reference the project for Architectural, Civil & Structural, Mechanical & Electrical Model, refer [here](#)

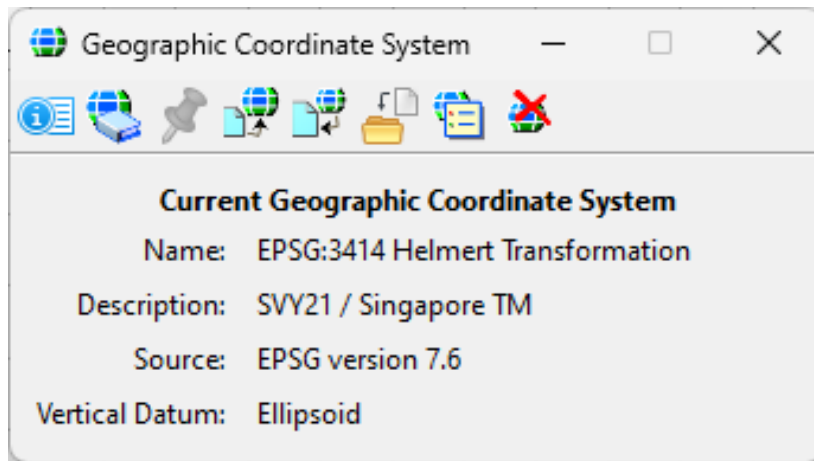

S4 – Fig 39

## ► 2. Identify the IFC properties to be tagged into each element of your model

- Element's properties can be assigned while Modelling.

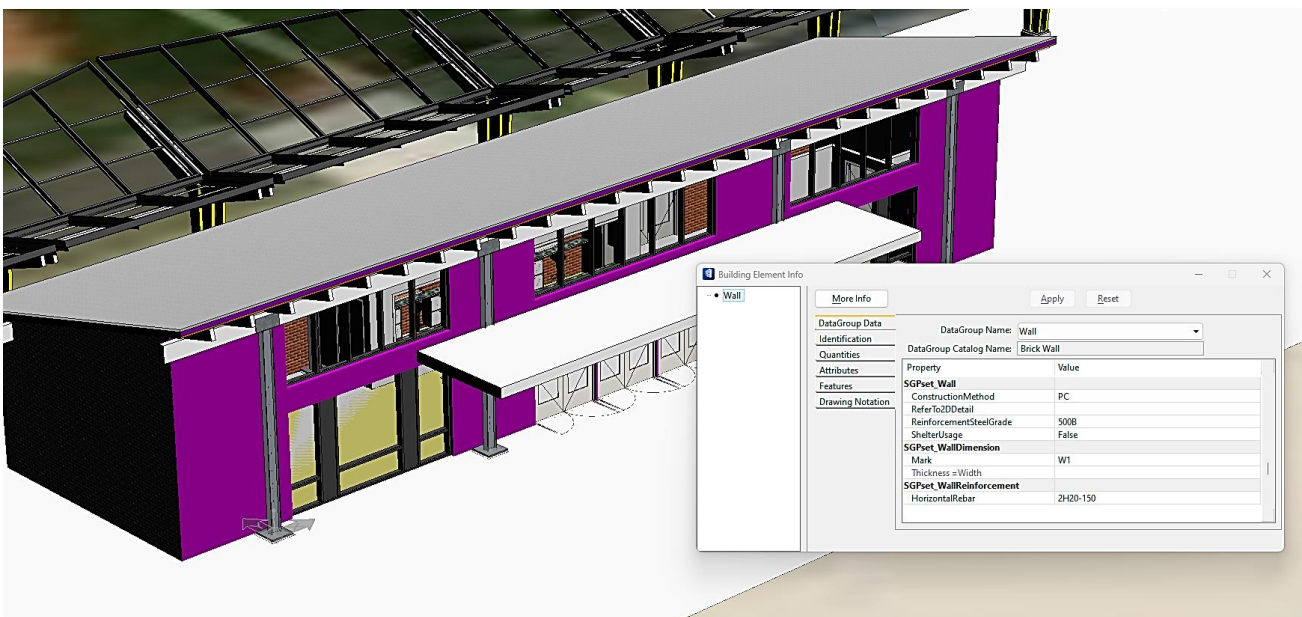

S4 – Fig 40

Link:  
[IFC-SG Resource Kit](#)

# Preparing Models for Submission (OpenBuildings Designer)

Example using OpenBuildings Designer Configuration File

## 3. IFC-SG Mapping

- The IFC category of elements are automatically assigned for default elements.
- IFC4Override is to be assigned for elements with different IFC Entity.
- If necessary, default mapping of datagroup can be modified (CAD Admin level)

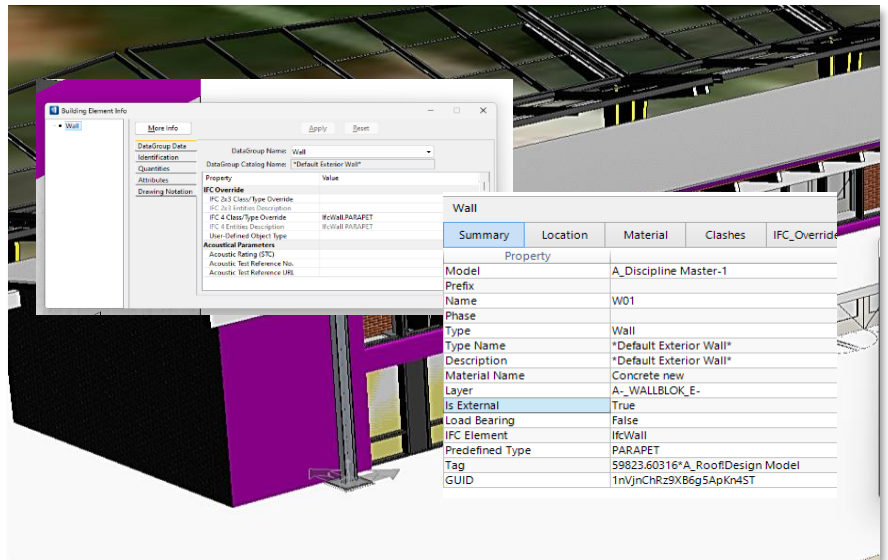

S4 – Fig 41

## 4. Export IFC Model

- Edit the IFC4\_PropertyMapping.set to map the properties for company or project components to reduce manual typing

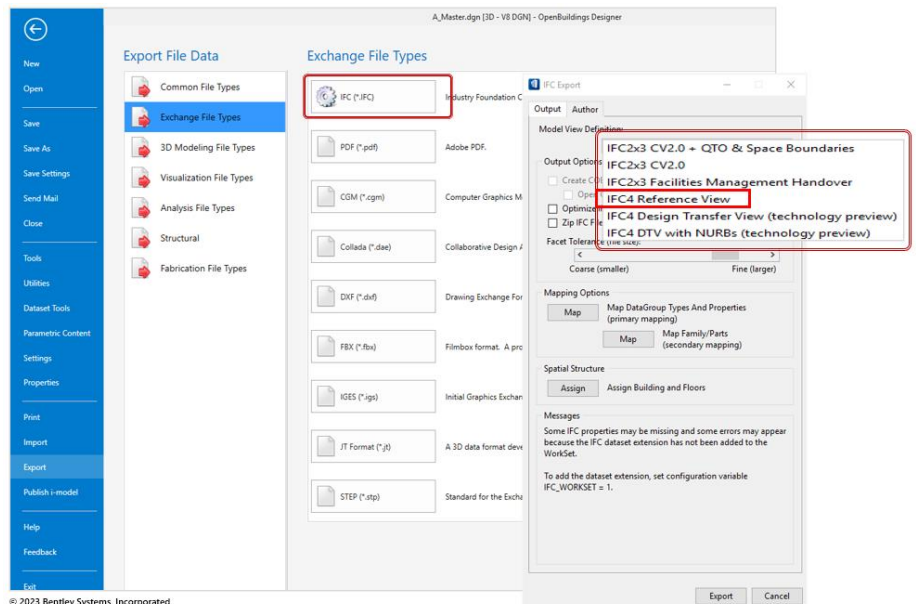

S4 – Fig 42

Link:  
[IFC-SG Resource Kit](#)

# Preparing Models for Submission (OpenBuildings Designer)

Example using OpenBuildings Designer Configuration File

## ► From OpenBuildings Designer

- Edit the IFC4\_PropertyMapping.set to map the properties for company or project components to reduce manual typing.

```

69 Concrete Beam * Pset_BeamCommon FireRating IfcLabel ObjectFireResistance/@Rating
70 Concrete Beam * Pset_BeamCommon IsExternal IfcBoolean ObjectThermalTransmittance/@IsExternal
71 Concrete Beam * Pset_BeamCommon LoadBearing IfcBoolean EVALUATE DG("ObjectStructuralUsage/@StructuralFunction") EQ "STRUCTURAL_VALUE";
72 Concrete Beam * SGPset_BeamDimension MemberSection IfcLabel StructuralFramingCommon/@sectionname
73 Concrete Column * Pset_ColumnCommon FireRating IfcLabel ObjectFireResistance/@Rating
74 Concrete Column * Pset_ColumnCommon IsExternal IfcBoolean ObjectThermalTransmittance/@IsExternal
75 Concrete Column * Pset_ColumnCommon LoadBearing IfcBoolean EVALUATE DG("ObjectStructuralUsage/@StructuralFunction") EQ "STRUCTURAL_VALUE";
76 Concrete Column Circular Column SGPset_ColumnDimension Diameter IfcLengthMeasure StructuralFramingCommon/@sectionname
77 Concrete Column * SGPset_ColumnDimension Height IfcLengthMeasure StructuralQuantities/@Length
78 Concrete Column * SGPset_ColumnDimension MemberSection IfcLabel StructuralFramingCommon/@sectionname
79 Concrete Pier * Pset_MemberCommon FireRating IfcLabel ObjectFireResistance/@Rating
80 Concrete Pier * Pset_MemberCommon IsExternal IfcBoolean ObjectThermalTransmittance/@IsExternal
81 Concrete Pier * Pset_MemberCommon LoadBearing IfcBoolean EVALUATE DG("ObjectStructuralUsage/@StructuralFunction") EQ "STRUCTURAL_VALUE";
82 Concrete File * Pset_MemberCommon FireRating IfcLabel ObjectFireResistance/@Rating
83 Concrete File * Pset_MemberCommon IsExternal IfcBoolean ObjectThermalTransmittance/@IsExternal
84 Concrete File * Pset_MemberCommon LoadBearing IfcBoolean EVALUATE DG("ObjectStructuralUsage/@StructuralFunction") EQ "STRUCTURAL_VALUE";
    
```

S4 – Fig 43

## ► From IFC Model

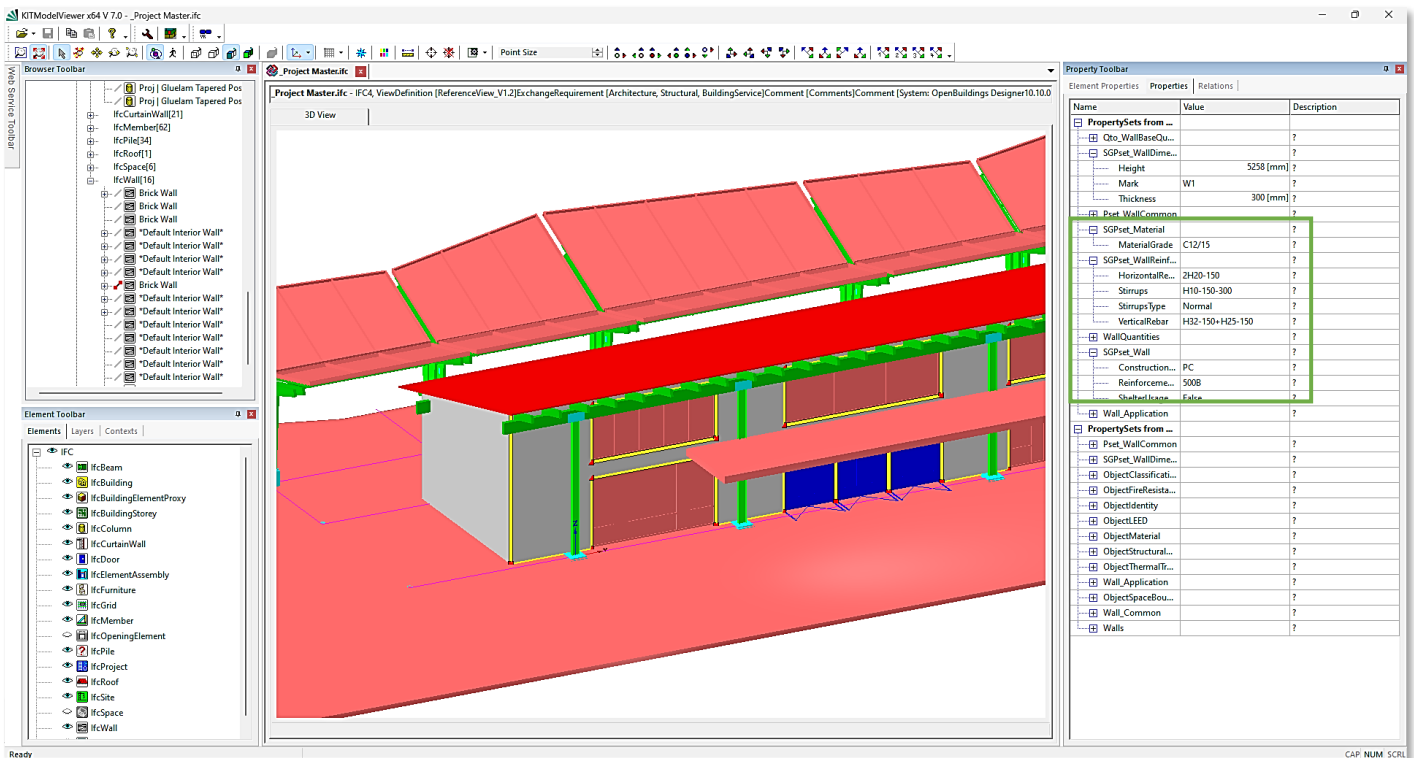

S4 – Fig 44

Link:  
[IFC-SG Resource Kit](#)

## Top 3 Common Modelling Challenges and Solutions (OpenBuildings Designer)

Example using OpenBuildings Designer Configuration File

### ► Challenge 1

Challenge	Implications	Solutions
Unable to see IFC Psets	➤ <b>Missing data in IFC</b>	✓ <b>Set IFC_Workset=3</b>
	<ul style="list-style-type: none"> <li>Model could export to IFC4x3 but unable to see default psets &amp; sgpsets.</li> </ul>	<ul style="list-style-type: none"> <li>Open the workset cfg file and set <u>IFC_Workset=3</u> to see the IFC Psets &amp; SGPsets.</li> </ul> <p><u>For on-going projects:</u></p> <ul style="list-style-type: none"> <li>Apply a <u>schema upgrade</u> for on-going projects</li> </ul>

### ► Challenge 2

Challenge	Implications	Solutions
Values of properties could not be applied	➤ <b>Missing data in IFC</b>	✓ <b>Apply Schema Upgrade</b>
	<ul style="list-style-type: none"> <li>Able to see the SGPset properties in the model but values are empty and won't be exported</li> </ul>	<p><u>For on-going projects:</u></p> <ul style="list-style-type: none"> <li>Apply a <u>schema upgrade</u> for on-going projects</li> </ul>

# 3<sup>rd</sup> Party Application(s) to help with Preparation of IFC-SG Models (IFC-SG Validator)

Example using IFC-SG Validator  
 (Free to Use)

## ► How does the IFC-SG Validator work?

- The IFC-SG Validator extracts all elements from the model and check whether IFC-SG parameters have been added to the corresponding BIM components in the model. This helps to check whether the QP have missed out any IFC-SG parameters when mapping IFC-SG data into the proprietary BIM model earlier.

## ► Setting up the IFC Model

### Pre-Requirement

- ✓ IFC Model
- ✓ IFC-SG Mapping File (Optional). Can be found in the [IFC-SG resource kit](#).

### Preparing the Model

- ✓ Input parameters into model.
- ✓ Instructions can be found in the [IFC-SG resource kit](#).

### Validation Overview

Go to: <https://www.code.builtsearch.com/ifcsg-validator>

- ✓ Upload IFC Model
- ✓ Upload IFC-SG Mapping file (Optional)
- ✓ View Result

Link:  
[IFC-SG Resource Kit](#)



## 3<sup>rd</sup> Party Application(s) to help with Preparation of IFC-SG Models (IFC-SG Validator)

Example using IFC-SG Validator  
(Free to Use)

### ► Guide to use the IFC-SG Validator Application

#### Step 1

Go to:

<https://www.code.builtsearch.com/ifcsg-validator>

- ✓ Click on 'Upload IFC' and select an IFC Model

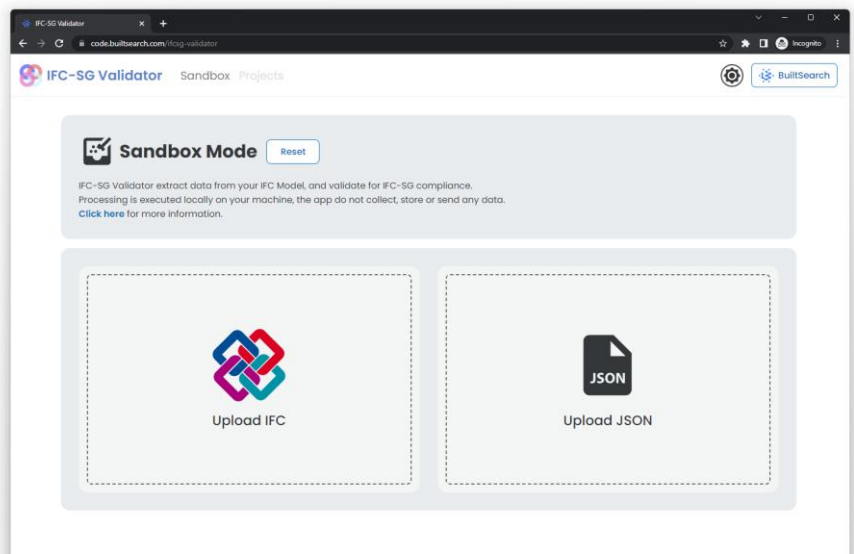

Note:

Work best on chromium-based browser (Microsoft Edge, Chrome, Brave, etc.) and Mozilla Firefox. For extremely large model >400mb, Firefox is preferred to avoid memory limit for chromium browser. All versions of Internet Explorer is not supported.

#### Step 2

- ✓ By default, IFC-SG Validator uses the latest IFC-SG Mapping file from [IFC-SG resource kit](#)
- ✓ To use a different Mapping table, upload your version of IFC-SG Mapping file.
- ✓ Leave processing threads as default for consistent results.

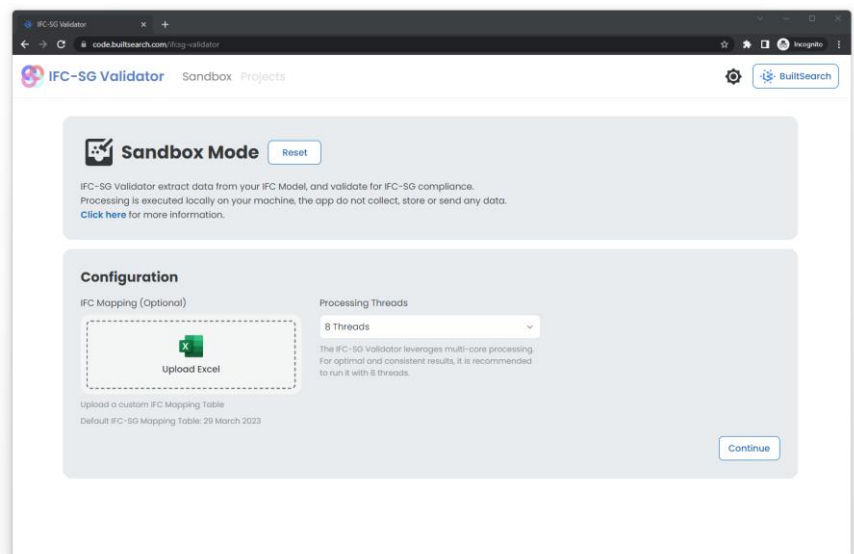

Note:

For extremely large model >400mb and when using chromium browser, lower processing threads to 2-3 to avoid hitting memory limit, which will crash the browser.

Link:

[IFC-SG Resource Kit](#)

# 3<sup>rd</sup> Party Application(s) to help with Preparation of IFC-SG Models (IFC-SG Validator)

Example using IFC-SG Validator  
(Free to Use)

## ► Guide to use the IFC-SG Validator Application

### Step 3

- ✓ View results
- ✓ The score should not be taken at face value, as the score is calculated by the presence of each element for each entity property in your IFC Model as compared to IFC-SG properties listed in the mapping file.
- ✓ Depending on your project's nature, it may not be relevant to have certain missing elements, therefore the score should only be used as an estimation.

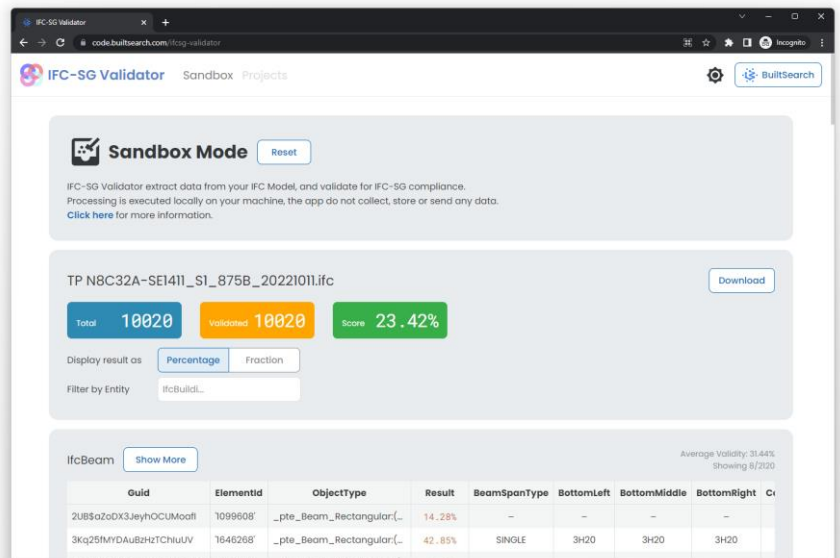

### Step 4

- ✓ By clicking on the download button, you will download a JSON file of this model's IFC-SG Validator result, which can then be uploaded on the home page.
- ✓ This will load the result immediately without processing the model again.

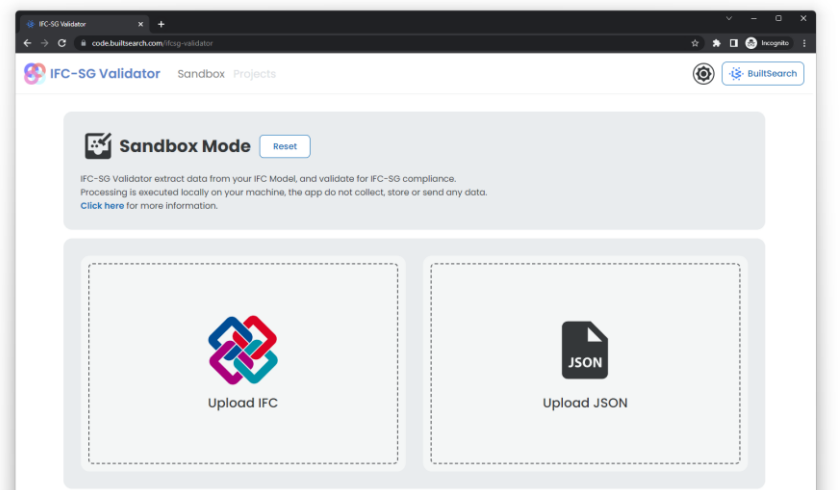

Note: By using the IFC-SG Validator Application, users will have to agree with the terms of use and privacy notice as stated in the website.

Link:  
[IFC-SG Resource Kit](#)

## 3<sup>rd</sup> Party Application(s) to help with Preparation of IFC-SG Models (DiRoots)

### Example using DiRoots Plugin

(Free Plugin)

#### ► How does the Plugin work?

- DiRoots is a free plug-in to export BIM data (Model and Annotation Categories, Elements and Schedules) from Revit to Excel or Google Spreadsheets, and import it back to update the model.



#### ► Example of Workflow using the Plugin

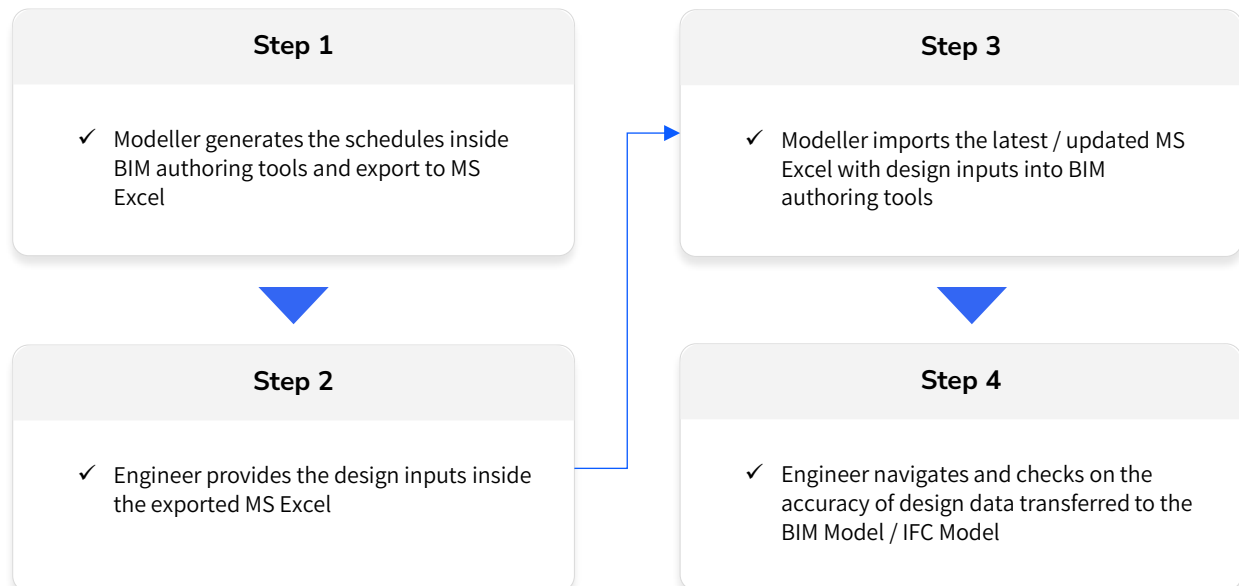

Link:

[IFC-SG Resource Kit](#)

[DiRoots Sheet Link Tutorial](#)

# 3<sup>rd</sup> Party Application(s) to help with Preparation of IFC-SG Models (DiRoots)

**Example using DiRoots Plugin**  
*(Free Plugin)*

## ► Guide to use DiRootsOne Plugin

\* Note user interface may differ for different versions of DiRoots

### Step 1

- ✓ Generate the IFC-SG schedules using 'DiRoots - SheetLink', in preparation to export it as MS Excel

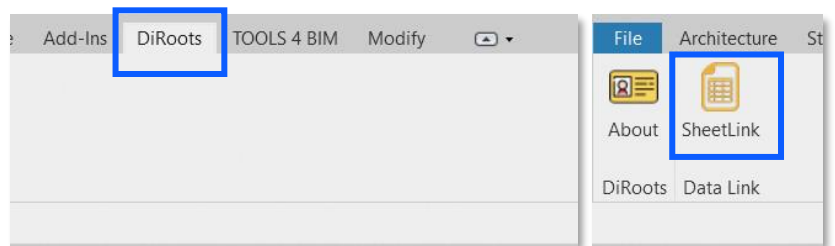

S4 – Fig 45

### Step 2

- ✓ Ensure that selection is 'Whole Model'
- ✓ Go to 'Schedules' and select the schedules accordingly (e.g. Wall, Beam)
- ✓ The values in the 'Schedules' are default parameter values which are automatically generated and referenced from the name that is set in the schedule header

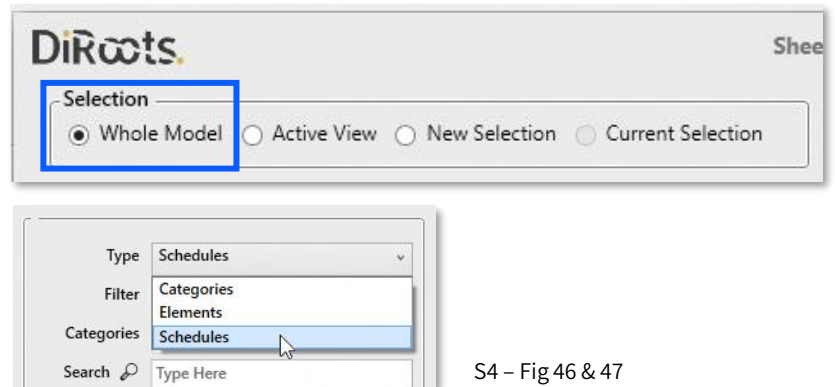

S4 – Fig 46 & 47

### Step 3

- ✓ 'Export' schedule to Excel or Google Sheet. There's a completion bar that tracks the exporting progress

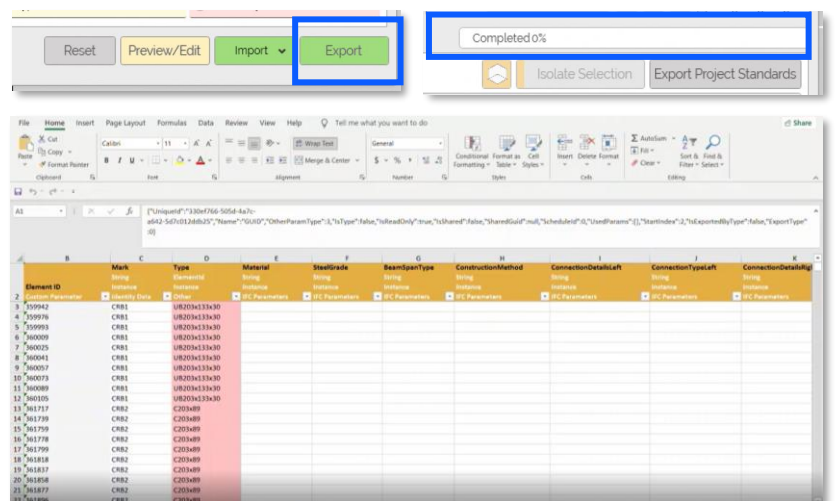

S4 – Fig 48

Link:  
[IFC-SG Resource Kit](#)  
[DiRoots Sheet Link Tutorial](#)

# 3<sup>rd</sup> Party Application(s) to help with Preparation of IFC-SG Models (DiRoots)

Example using DiRoots Plugin  
 (Free Plugin)

## ► Guide to use DiRoots Plugin

\* Note user interface may differ for different versions of DiRoots

### Step 4

- ✓ Design Engineer provides the design inputs (i.e. project specific parameters) into the exported 'Schedules' Excel

S4 – Fig 49

### Step 5

- ✓ 'Import' the updated 'Schedules' Excel back into DiRoots and the parameters will be updated accordingly

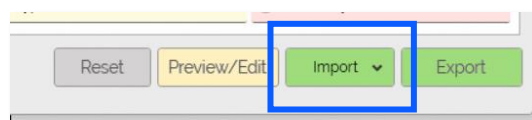

S4 – Fig 50

- [Automated] Default Parameter Values populated by Revit Families
- [Imported from Excel] Project Specific Parameter Values by Design Engineer

Project Browser - SE1411\_S1\_875B\_FDN

Views (BCA,BIM)

- Structural-3D
- Structural-FE
  - Elevation: ST\_FE\_East Elevation
  - Elevation: ST\_FE\_North Elevation
  - Elevation: ST\_FE\_South Elevation
  - Elevation: ST\_FE\_West Elevation
- Structural-FP
- Legends
- Schedules/Quantities (all)
  - IFC Structural BORED-PILE Schedule**
  - IFC Structural PILE CAP Schedule
  - WORKING\_Structural BORED-PILE Schedule
  - WORKING\_Structural PILE CAP Schedule

A	B	C	D	E	F	G	H	I	J	K	L	M	N
IFCExportAs	IFCObjectType	IFCGroupMark	Mark	Diameter	BoreholeRef	Material	StrengthClass	ReinforcementSteelGrade	ConstructionMethod	PileType	Length	HeadLevel	ToeLevel
IFCFile Type BORED	IFCFile Type	G1	P1E	1000	BH3	Concrete	C32/40	500	Bored Pile	CIS	24300	10.75	-13.55
IFCFile Type BORED	IFCFile Type	G2	P1C	800	BH3	Concrete	C32/40	500	Bored Pile	CIS	20500	10.35	-10.15
IFCFile Type BORED	IFCFile Type	G2	P2C	800	BH3	Concrete	C32/40	500	Bored Pile	CIS	20500	10.35	-10.15
IFCFile Type BORED	IFCFile Type	G3	P1C	800	BH3	Concrete	C32/40	500	Bored Pile	CIS	20500	10.35	-10.15
IFCFile Type BORED	IFCFile Type	G3	P2C	800	BH3	Concrete	C32/40	500	Bored Pile	CIS	20500	10.35	-10.15
IFCFile Type BORED	IFCFile Type	G4	P1E	1000	BH3	Concrete	C32/40	500	Bored Pile	CIS	24300	10.75	-13.55
IFCFile Type BORED	IFCFile Type	G5	P1E	1000	BH3	Concrete	C32/40	500	Bored Pile	CIS	24300	10.75	-13.55
IFCFile Type BORED	IFCFile Type	G6	P1C	800	BH3	Concrete	C32/40	500	Bored Pile	CIS	20500	10.35	-10.15
IFCFile Type BORED	IFCFile Type	G6	P2C	800	BH3	Concrete	C32/40	500	Bored Pile	CIS	20500	10.35	-10.15
IFCFile Type BORED	IFCFile Type	G7	P1C	800	BH3	Concrete	C32/40	500	Bored Pile	CIS	20500	10.35	-10.15

Project Browser - SE1411\_S1\_875B...

Views (BCA,BIM)

- Structural-3D
- Structural-FE
- Structural-FP
- Legends
- Schedules/Quantities (all)
  - IFC Structural BEAM**
  - IFC Structural COLUMN
  - IFC Structural DUCT, FACADE
  - IFC Structural SLAB
  - IFC Structural WALL

A	B	C	D	E	F	G	H	I	J	K	L	M	N	O
IFCExportAs	IFCObjectType	Mark	Width x Depth	MemberSection	Material	StrengthClass	ReinforcementSteelGrade	ConstructionMethod	BeamSpanType	TopLeft	TopMiddle	TopRight	BottomLeft	BottomMiddle
IFCBeamType BEAM	IFCBeamType	PT401	(300x500)	Rectangle	Concrete	C32/40	500	PC	SINGLE	3H16	3H16	3H16	3H20	3H20
IFCBeamType BEAM	IFCBeamType	PT401	(300x500)	Rectangle	Concrete	C32/40	500	PC	SINGLE	3H16	3H16	3H16	3H20	3H20
IFCBeamType BEAM	IFCBeamType	PT402	(300x500)	Rectangle	Concrete	C32/40	500	PC	SINGLE	3H16	3H16	3H16	3H25	3H25
IFCBeamType BEAM	IFCBeamType	PT403	(300x500)	Rectangle	Concrete	C32/40	500	PC	SINGLE	3H20	3H20	3H20	3H20	3H20
IFCBeamType BEAM	IFCBeamType	PT403	(300x500)	Rectangle	Concrete	C32/40	500	PC	SINGLE	3H20	3H20	3H20	3H20	3H20
IFCBeamType BEAM	IFCBeamType	PT405	(250x480)	Rectangle	Concrete	C32/40	500	PBU	SINGLE	2H20	2H20	2H20	2H25-2H20	2H25-2H20
IFCBeamType BEAM	IFCBeamType	PT405	(250x480)	Rectangle	Concrete	C32/40	500	PBU	SINGLE	2H20	2H20	2H20	2H25-2H20	2H25-2H20

S4 – Fig 51 & 52

Link:  
[IFC-SG Resource Kit](#)  
[DiRoots Sheet Link Tutorial](#)

## List of Recommended IFC Viewers

**Note that this list is not exhaustive**

*(Free to use)*

### ► Importance of reviewing IFC models before submission

- It is strongly encouraged to review your project team's models in an IFC viewer to ensure the models did not experience errors during the export process from their respective BIM software.

	Name	View IFC4	Federation of IFC(s)	Viewing of System Entities *	View IfcGrid	Search Query	Remarks
1	BIMCollab Zoom	○	○	✗	✗	○	Suitable for federation of IFC files, handle large files well
2	BIMVision	○	Up to 2 files	○	○	○	Suitable for quick visualization of IFC files
3	Kit Model Viewer (replacing FZK Viewer)	○	✗*	○	○	○	Suitable for analysing smaller files (< 200 MB)
4	ODA (Open Design Alliance) Open IFC Viewer	○	○	✗	○	✗	-
5	Solibri Anywhere	○	✗*	○	○	○	-
6	Trimble Connect Desktop Version	○	○	○	○	○	-

\* To view multiple IFC files in FOC viewers that are unable to federate IFC models, the “IFC-SG Integrator” could be used, available at the [IFC-SG Resource Kit](#). This application is based on C# and is able to bind multiple IFC files

Link:

[IFC-SG Resource Kit](#)

## Model Quality Quick Checklist

### ► Use openBIM viewer on Submission Portal to verify your model quality

Create high-quality models to reduce the likelihood of withdrawals, minimise delays, and accelerate your project's approval process.



Upload your models in the openBIM Viewer on the CORENET X Submission Portal



Files should not experience any error prompt during or after export from the native BIM software



Under the “Coordinated BIM” tab in the CORENET X Submission Portal, upload BIM files and “preview (your) model” in the Lightweight BIM Viewer. This is a simplified version of the CORENET X Collaboration Platform used by officers

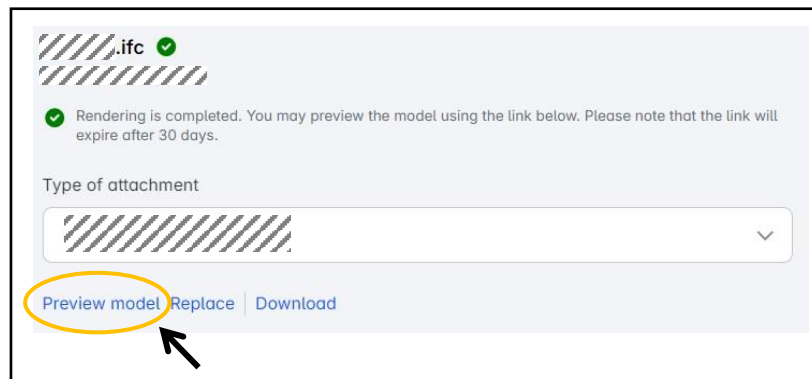

Select the models you wish to combine on the left-hand panel. Verify that these selected models appear correctly aligned and visible in the openBIM Viewer display on the right side of the screen.

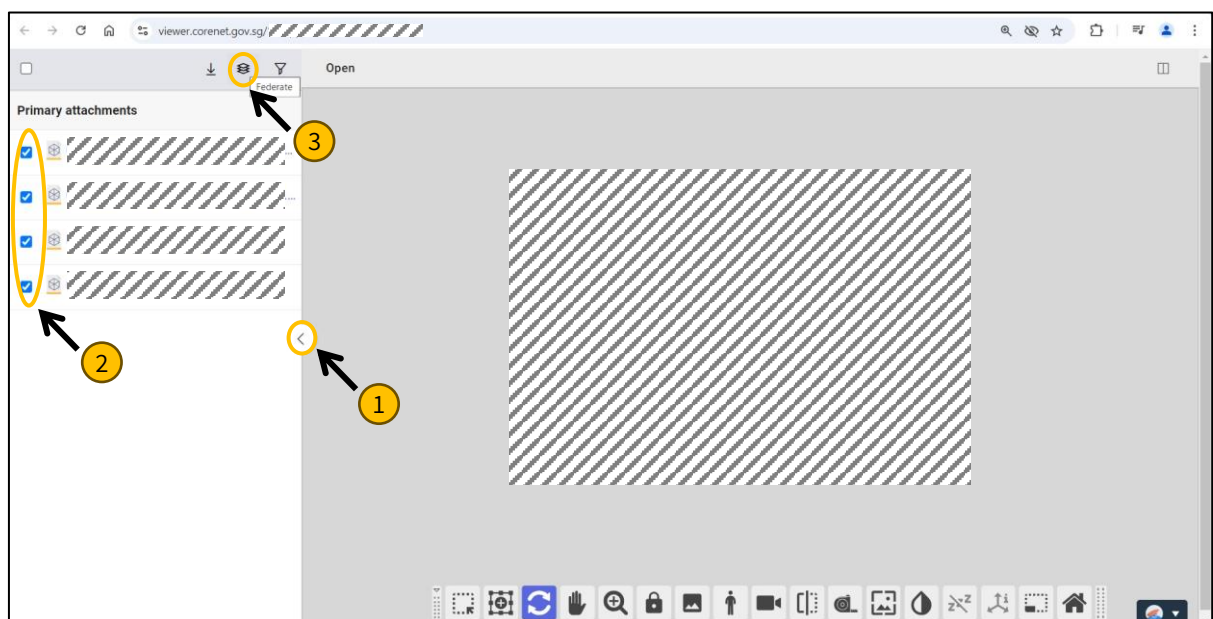

## Model Quality Quick Checklist



Check areas and spaces in your IFC models

- Check that storey-specific gross area does not deviate significantly from sum totals of the storey
- Do a tabulation of gross area by storey on the native BIM software
- Check against the sum totals of gross area before the export to IFC
  
- Ensure that attributes about cadastral lots, such as area, lot numbers as provided in the Project Information on the CORENET X Submission Portal are present
- Critical information like cadastral lot, lot numbers etc should be exported successfully into the IFC format
- There is no gap between boundaries of cadastral lots
  
- Check that spaces are directly adjacent to other space components, surrounding walls or floors below
- Check that each of the common boundary of any strata lots with another lot or with the common property are in the centre of the floor, wall or ceiling



Ensure the whole project team adopts model preparation and multi-disciplinary coordination good practices

- The project team should plan for sufficient time to align model coordination, planning and management workflows throughout the project
- Follow model preparation and multi-disciplinary good practice as elaborated in this section of the Code of Practice, as well as on the CORENET X IFC-SG Resource Toolkit and respective BIM vendor websites
- Do not leave the export and review of your IFC models to the last minute – models that are perfectly geo-referenced and mapped in the native BIM software may encounter unexpected problems after export into IFC

Link:

[IFC-SG Resource Kit](#)



## Glossary of “Identified Components”

	Pg		Pg		Pg
<b>A</b>		<a href="#">Foam Inlet / Outlet</a>	263	<b>R</b>	
<a href="#">Accessible Route</a>	229	<a href="#">Footpath</a>	264	<a href="#">Racking System</a>	297
<b>B</b>		<a href="#">Footing / Pilecap</a>	265	<a href="#">Railing</a>	298
<a href="#">Beam</a>	230	<b>G</b>		<a href="#">Ramp</a>	299
<a href="#">Borehole</a>	238	<a href="#">Grating</a>	270	<a href="#">Refuse Chute / Recyclables Chute</a>	300
<a href="#">Breeching Inlet</a>	239	<a href="#">Green Verges</a>	271	<a href="#">Refuse Handling Equipment</a>	302
<a href="#">Building Storey</a>	240	<a href="#">Gutter</a>	272	<a href="#">Road</a>	303
<b>C</b>		<b>H</b>		<a href="#">Roof</a>	306
<a href="#">Ceiling</a>	241	<a href="#">Hose Reel</a>	273	<b>S</b>	
<a href="#">Column</a>	242	<a href="#">Household Shelter</a>	274	<a href="#">Sanitary Appliances</a>	307
<a href="#">Control Element</a>	246	<b>I</b>		<ul style="list-style-type: none"> <li>• Bath</li> <li>• Bidet</li> <li>• Shower</li> <li>• Sink</li> <li>• Urinal</li> <li>• Wash Basin</li> <li>• Water Closet</li> </ul>	
<a href="#">Culvert / Drain</a>	247	<a href="#">Interceptor</a>	277	<a href="#">Seating</a>	310
<a href="#">Curtain Wall</a>	248	<b>L</b>		<a href="#">Security Lighting</a>	311
<b>D</b>		<a href="#">Lamp Post</a>	278	<a href="#">Sensor</a>	312
<a href="#">Damper</a>	249	<a href="#">Landscape Plants</a>	279	<a href="#">Shading Device</a>	313
<a href="#">* Distribution Chamber</a>	250	<a href="#">Lift</a>	280	<a href="#">Signage</a>	314
<a href="#">Door</a>	252	<b>P</b>		<a href="#">Site</a>	315
<b>E</b>		<a href="#">Parking Lot</a>	281	<a href="#">Site Boundary</a>	316
<a href="#">Earthworks</a>	255	<a href="#">Pile</a>	284	<a href="#">Slab</a>	317
<a href="#">Escalator</a>	255	<a href="#">Pipes / Drains</a>	289	<a href="#">Soffit</a>	320
<b>F</b>		<a href="#">Planter Box / Planting Trough</a>	291	<a href="#">** Space (About)</a>	321
<a href="#">Family-Friendly Furniture</a>	257	<a href="#">Planting Areas</a>	292-	<ul style="list-style-type: none"> <li>• <a href="#">Space (Area Scheme)</a></li> <li>• <a href="#">Space (Usage)</a></li> <li>• <a href="#">Space (Others)</a></li> </ul>	322
<a href="#">Finishes</a>	258	<a href="#">Pollution Control</a>	293		341
<a href="#">Fire Access Opening</a>	259	<a href="#">Prefabricated Building Systems and MEP Components</a>	294		375
<a href="#">Fire Alarm</a>	260	<a href="#">Project Development Type</a>	295	<a href="#">Sprinkler (Non-Fire) (For NEA)</a>	377
<a href="#">Fire Extinguisher</a>	261	<a href="#">Pump</a>	296	<a href="#">Staircase</a>	378
<a href="#">Fire Hydrant</a>	262			<a href="#">System</a>	381

## Glossary of “Identified Components”

	Pg
<b>T</b>	
<a href="#">Tank</a>	382
<a href="#">Type Bedding for Pipe</a>	383
<b>V</b>	
<a href="#">Valve</a>	384
<b>W</b>	
<a href="#">Wall</a>	385
<a href="#">Waste Terminal</a>	390
<a href="#">Water Meter</a>	391
<a href="#">Window</a>	392

### **Notes**

\* Distribution Chamber includes Inspection Chambers, Manholes, Meter Chambers, Sampling Sumps and Sumps.

\*\* As ‘IfcSpace’ is the most common component across all agencies, it is broken down into 2 sub-sections for ease of understanding. ‘IfcSpace’ consists of:

- Space (Area Schemes)
- Space (Usage)



## Modelling IFC-SG for Structural Submission

### ► List of inputs for IFC-SG Structural Parameters

Structural Parameters	
IFC-SG Property	List
BeamSpanType	<ul style="list-style-type: none"> <li>• Single</li> <li>• End</li> <li>• Interior</li> <li>• Cantilever</li> </ul>
ConnectionTypeBottom, ConnectionTypeTop, LeftConnectionType, or RightConnectionType	<ul style="list-style-type: none"> <li>• Pinned</li> <li>• Fixed</li> <li>• Free</li> </ul>
ConstructionMethod	<ul style="list-style-type: none"> <li>• CIS</li> <li>• PC</li> <li>• PT (Pre)</li> <li>• PT (Post)</li> <li>• PF</li> <li>• PPVC</li> <li>• Spun [for pile element only]</li> </ul>
MaterialGrade	<ul style="list-style-type: none"> <li>• C12/15</li> <li>• C20/25</li> <li>• C30/37</li> <li>• C32/40</li> <li>• C35/45</li> <li>• C40/50</li> <li>• C50/60</li> <li>• C55/67</li> <li>• C60/75</li> <li>• C70/85</li> <li>• C80/95</li> <li>• S235</li> <li>• S275</li> <li>• S355</li> <li>• S460</li> <li>• High Strength Concrete</li> </ul>
PileType	<ul style="list-style-type: none"> <li>• Driven</li> <li>• Bored</li> <li>• Jacked in</li> </ul>

Structural Parameters	
IFC-SG Property	List
ReinforcementLength	<ul style="list-style-type: none"> <li>• Fully reinforced</li> <li>• Unreinforced</li> <li>• Any numerical value [up to 1 decimal place]</li> </ul>
ReinforcementSteelGrade	<ul style="list-style-type: none"> <li>• 500A</li> <li>• 500B</li> <li>• 500C</li> <li>• 600A</li> <li>• 600B</li> <li>• 600C</li> </ul>
SectionFabricationMethod	<ul style="list-style-type: none"> <li>• Hot rolled</li> <li>• Cold formed</li> </ul>
SlabType	<ul style="list-style-type: none"> <li>• One way</li> <li>• Two way</li> <li>• Cantilever</li> <li>• Flat slab</li> <li>• Flat slab with drop panel</li> <li>• Transfer Slab</li> </ul>
StirrupsType, StirrupsTypeLeft, StirrupsTypeMiddle, or StirrupsTypeRight	<ul style="list-style-type: none"> <li>• Normal</li> <li>• U</li> <li>• C</li> <li>• CL [for civil defence shelter]</li> <li>• Torsion</li> </ul>

#### Abbreviation List:

CIS	- Cast in situ
PC	- Precast works
PT (Pre)	- Pre-tensioning works
PT (Post)	- Post-tensioning works
PF	- Prefabrication (e.g. steel, MET, etc.)
PPVC	- Precast-Prefabricate-Volumetric Component

Link:

[IFC-SG Resource Kit](#)

See also:

[Preparing models for submission](#)



## Modelling IFC-SG for SCDF Submission

### The following fire safety equipment / provision need not be shown in the model.

- Equipment, furniture, fixture (e.g. lighting, fans)
- Wiring connecting various system in building

### The following fire safety equipment / provision need not be modelled in full.

They can be represented by suitable objects.

If the equipment / provision is applicable only to Independent Submission, they can be represented in 2D.

- |  |  |
|--|--|
| <ul style="list-style-type: none"> <li>• Signage (exit staircase numbering, evacuation lift, re-entry floor, etc)</li> <li>• Signage for “PWD Holding Point”</li> <li>• Mean of communication between PWD holding point and FCC/24 hourly manned station.</li> <li>• Override device</li> <li>• Fire stopping material (for filling gap)</li> <li>• Composite panel</li> <li>• Hose reel drum (excluding cabinet/enclosure)</li> <li>• Breathing apparatus cabinet/enclosure (for Total flooding fire extinguishing system)</li> <li>• Generator/emergency generator/standby generator</li> <li>• transformer</li> <li>• Fire extinguisher</li> <li>• Housing cabinet/enclosure</li> <li>• Main fire alarm panel/cabinet</li> <li>• Sub fire alarm panel/cabinet</li> <li>• Manual call point</li> <li>• Standby hose cabinet/enclosure</li> <li>• Bell for manual alarm</li> <li>• Vision alarm – strobe light</li> <li>• Smoke/heat detector</li> <li>• Home Fire Alarm Device (HFAD)</li> <li>• Video Image Fire Detection System (VIFDS)</li> <li>• Sprinkler head</li> <li>• Sprinkler control valve</li> </ul> | <ul style="list-style-type: none"> <li>• Fire pump &amp; control panel</li> <li>• Fire water tank</li> <li>• Compressed cylinders &amp; discharge nozzle for Water mist system</li> <li>• Compressed cylinders &amp; discharge nozzle for fixed automatic fire extinguishing systems (e.g kitchen suppression system, GM200, etc)</li> <li>• Fire lift switch</li> <li>• Evacuation switch</li> <li>• Intercom system in fire lift</li> <li>• CCTV camera</li> <li>• Lift control panel</li> <li>• Lift car</li> <li>• Standby fans/ multiple fans</li> <li>• Fire damper</li> <li>• Smoke damper</li> <li>• Air-handling unit</li> <li>• Air conditioner compressor + unit</li> <li>• Exit/directional exit sign (high level and low level)               <ul style="list-style-type: none"> <li>• Need to provide arrow if for directional exit sign</li> </ul> </li> <li>• Emergency lighting</li> <li>• Photoluminescent marking</li> <li>• Equipment/services in Fire Command Centre mentioned in Cl. 8.2.4b.</li> <li>• Speakers for public address system/emergency voice communication system</li> <li>• Handset/cabinet/enclosure (for emergency voice communication system)</li> </ul> |
|--|--|

Link:

[IFC-SG Resource Kit](#)

See also:

[Preparing models for submission](#)

## Accessible Route

### ► Modelling Accessible Route in IFC-SG

- This component can be modelled with Generic Models (Revit), Model Element (ArchiCAD), or Object (OpenBuildings) functions in the respective Native BIM software
- Other components that could be viewed with Accessible Route may include: Lift, Ramp, Slab, Space, Vehicular Parking, if they contain a positive BarrierFreeAccessibility property

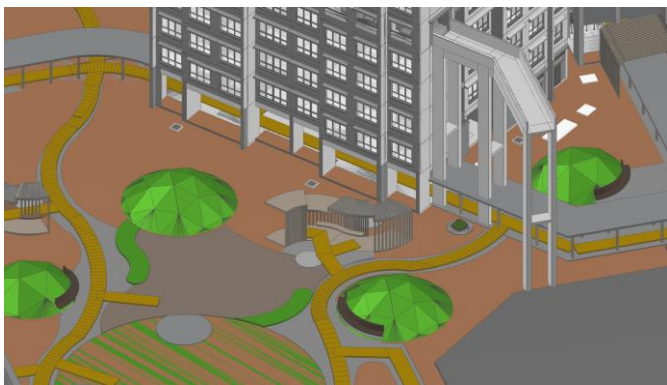

S4 – Fig 1: Accessible Route within BIM model

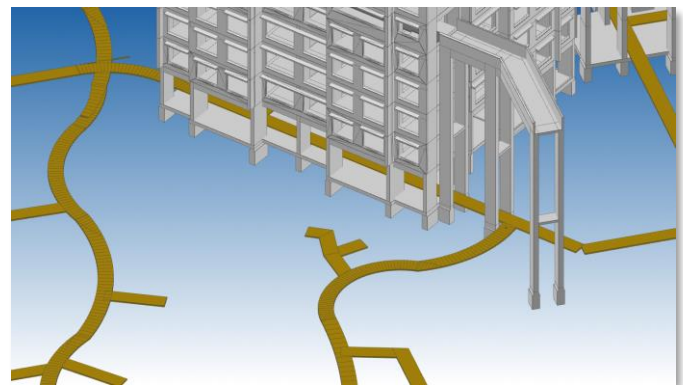

S4 – Fig 2: Accessible Route with BIM model hidden

### ► By IFC Representation

IFC Entity: <b>IfcBuildingElementProxy, IfcSlab, IfcCivilElement, IfcRamp, IfcSpace</b>						
IFC SubType: ACCESSIBLEROUTE						
S/N	IFC-SG Property	Property Type	Type of Elements	Unit	Input Limitation	Examples
1	BarrierFreeAccessibility	Boolean	-	-	Yes	TRUE / FALSE
2	Width	Length	-	mm	No	1200

# Beam

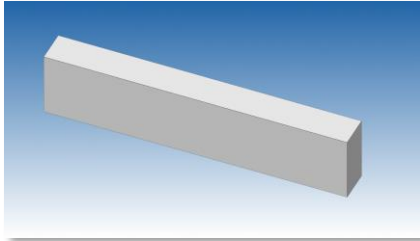

S4 – Fig 3 : Beam

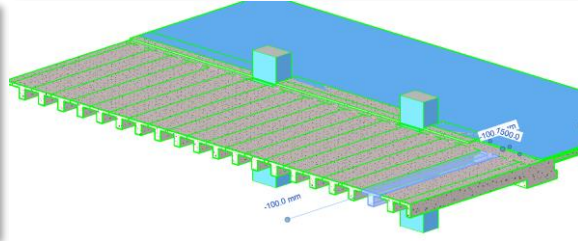

S4 – Fig 4 : Concrete Rectangular Beam

## ► Modelling Beam in IFC-SG

- All the beam elements shall be modelled in IFC-SG model with the necessary information required as stipulated in the tables below.
  - Typical beams are allowed to have same marks and design information. All marks and design information have to be embedded in every beam element.
  - Multiple beams elements shall be modelled from support to support for beams with continuous spans.
- 2D detail drawings are allowed for any irregular or complex beam design (e.g. transfer beams, precast beams, prestressed beams, cold-form steel beams, etc.) with the indication of drawing number in the IFC-SG parameter “ReferTo2DDetail”.

## ► Beam Property Definition

Beam Property Definition	
<b>1</b>	Every beam will be detailed based on 3 parts (left, middle & right) in accordance to its local building axis orientation (refer to Figure 5 below).
<b>2</b>	Starting point of a beam should be the smallest x coordinate of local building axis orientation in a span and denoted as left part of a beam.
<b>3</b>	Behaviour of the beam (single, end, interior & cantilever span) shall be indicated in the parameters called “BeamSpanType”. Limitation of inputs for this parameter is applied. Please refer to <a href="#">list</a> of input.

Scenario 1

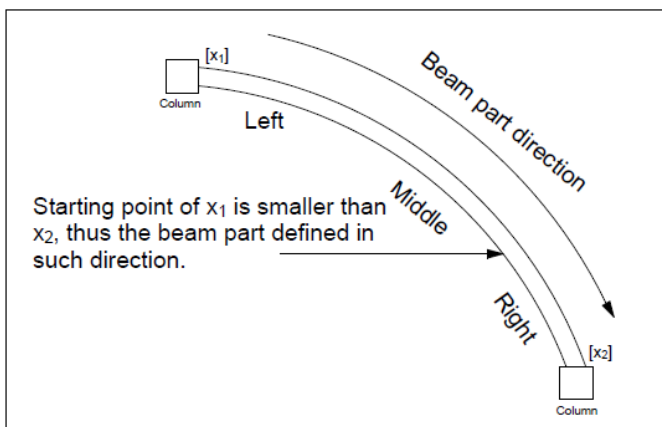

Scenario 2

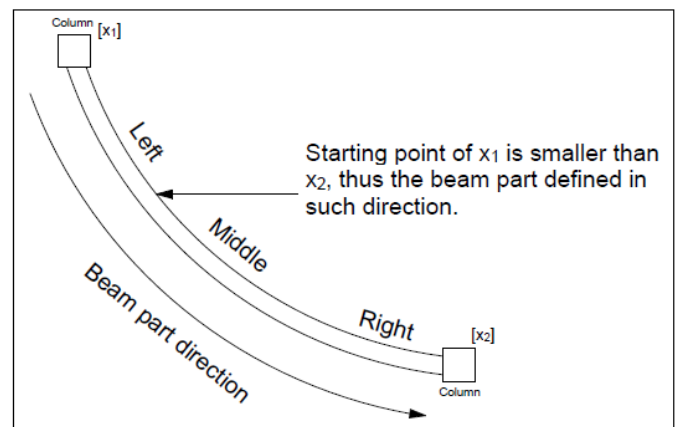

S4 – Fig 5 : Beam Part Definition

# Beam

## ► Beam Property Definition (continued from previous page)

Scenario 3

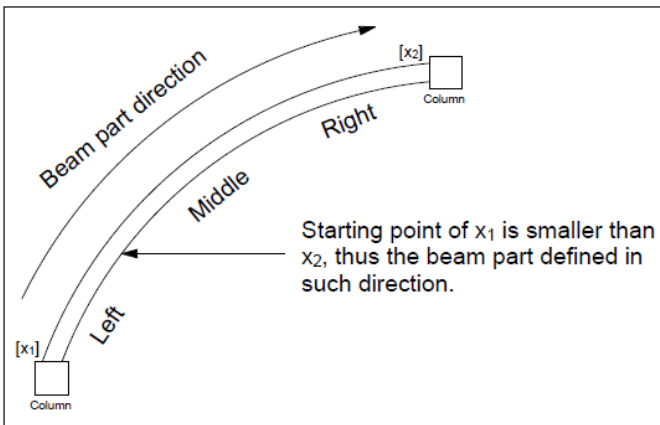

Scenario 4

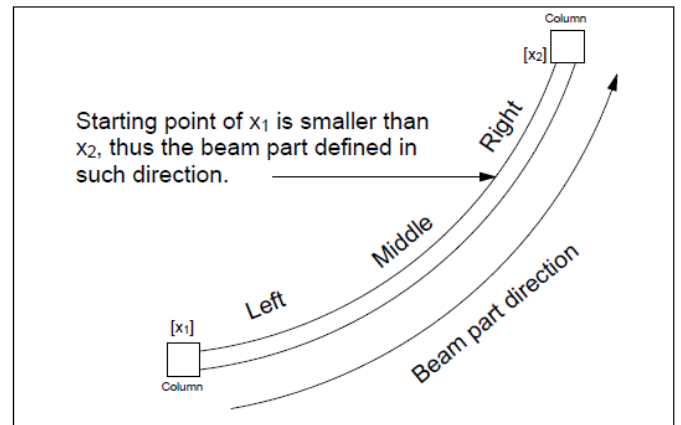

S4 – Fig 5 : Beam Part Definition (continued from previous page)

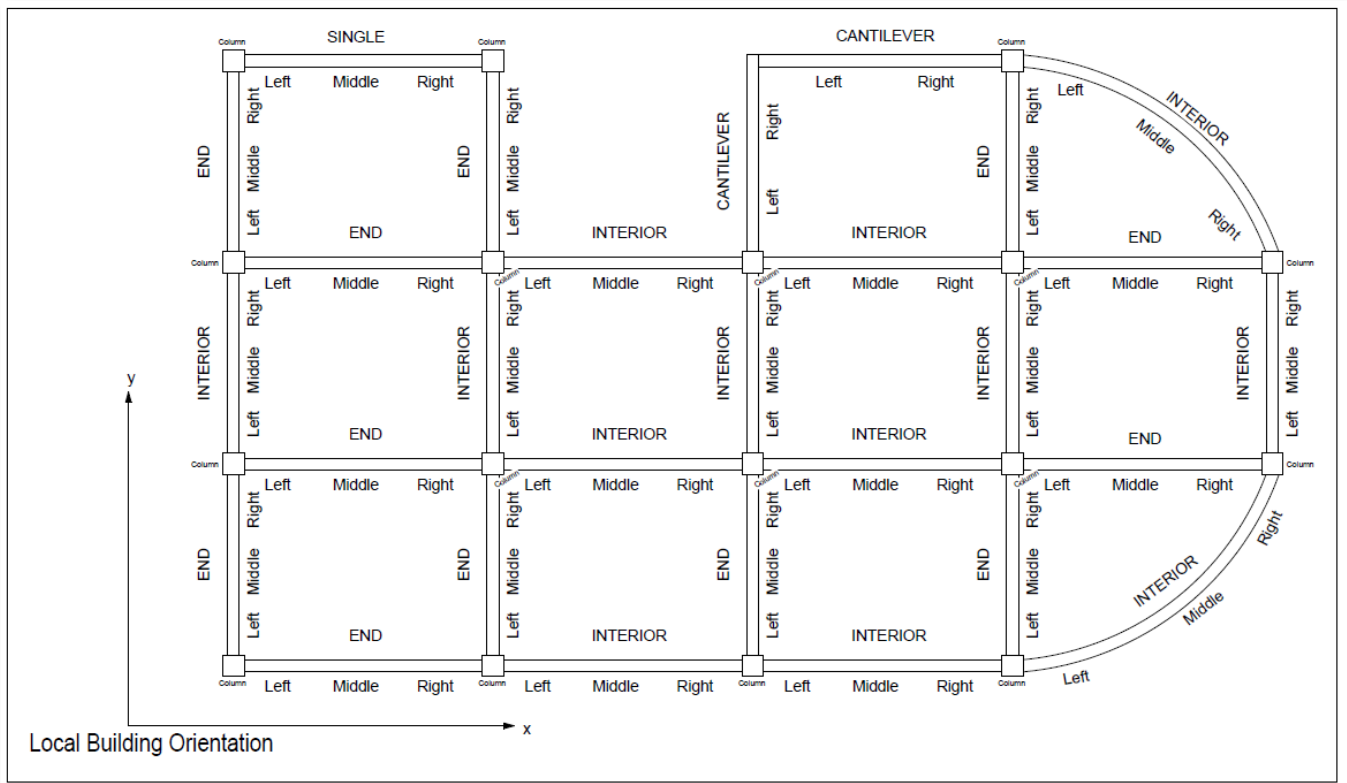

S4 – Fig 6 : Beam Sequencing and Span Definition

# Beam

## ► Beam Reinforcement Definition

Beam Reinforcement Definition	
1	A set of typical beam reinforcement annotation is provided for reference.
2	QP may provide a set of 2D typical drawings to present typical beam reinforcement annotation based on the standardised IFC-SG parameter names.
3	<p>The input for TopLeft, TopMiddle, TopRight, BottomLeft, BottomMiddle &amp; BottomRight shall be "XXHXX" while "H" is a must, 1st XX is number of longitudinal reinforcement &amp; 2nd XX is the reinforcement diameter</p> <ul style="list-style-type: none"> <li>Use '+' for more than 1 layer of reinforcement (e.g. 12H32+6H20)</li> </ul> <div style="text-align: center;"> </div>
4	<p>The input for StirrupsLeft, StirrupsMiddle &amp; StirrupsRight shall be "XXHXX-XXX" while "H" is a must, 1st XX is number of legs for transverse reinforcement, 2nd XX is the reinforcement diameters and XXX is the spacing of transverse reinforcement.</p> <ul style="list-style-type: none"> <li>Use '+' for more than 1 layer of reinforcement (e.g. 4H10-100 : [4 denotes 4 legs])</li> </ul> <div style="text-align: center;"> </div>
5	Type of the beam stirrups (Normal link, U-link, C-link or torsion link) shall be indicated in the parameters called "StirrupType" based on beam part. Limitation of inputs for this parameter is applied. Please refer to <a href="#">list</a> of input. This parameter is optional for input.

### SINGLE SPAN BEAM REINFORCEMENT ANNOTATION

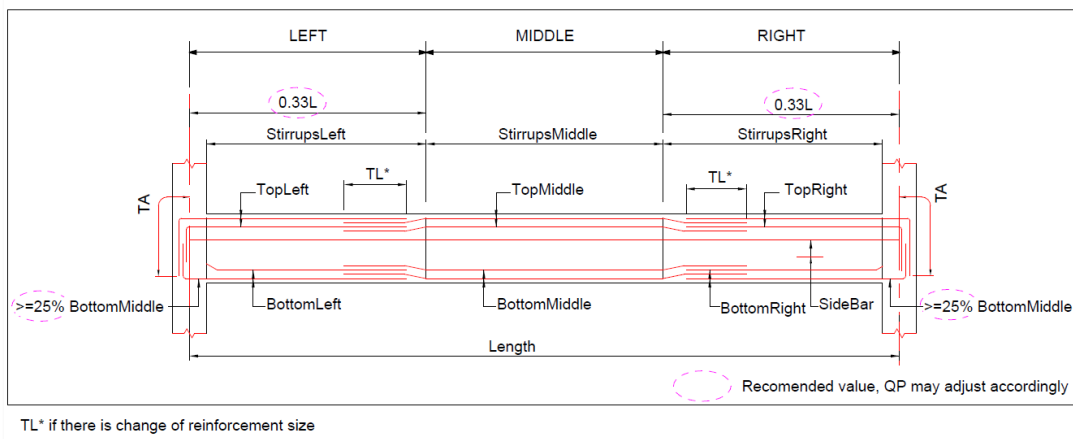

S4 – Fig 7: Beam Annotation Single Span



# Beam

## ► Beam Reinforcement Definition (continued from previous page)

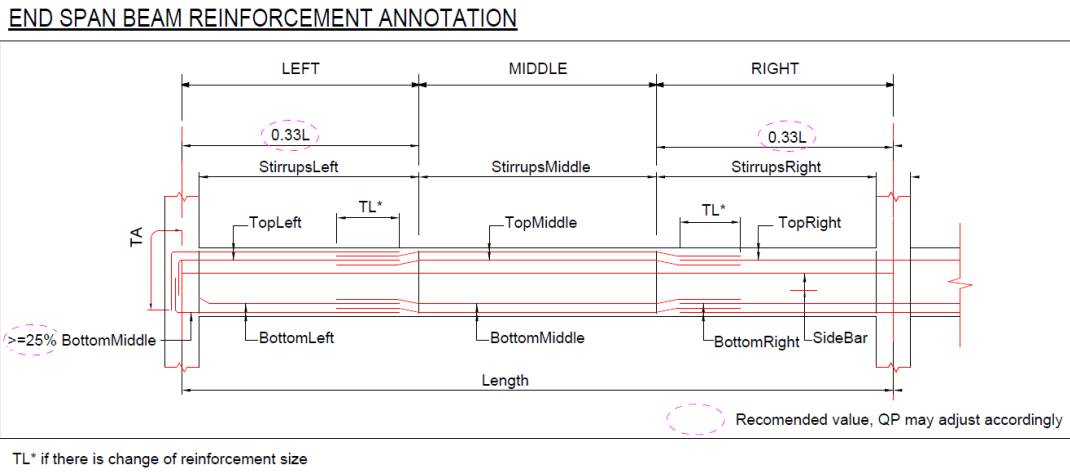

S4 – Fig 8 : Beam Annotation End Span

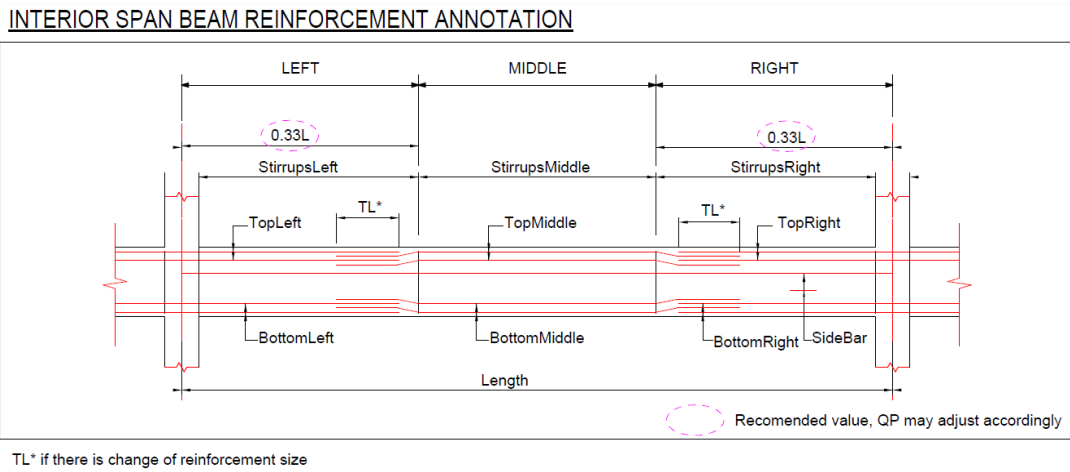

S4 – Fig 9 : Beam Annotation Interior Span

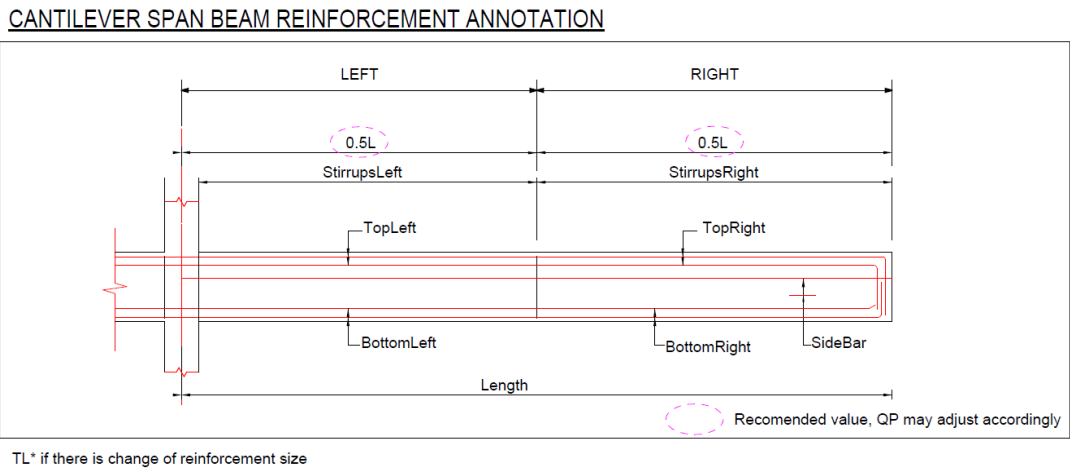

S4 – Fig 10 : Beam Annotation Cantilever Span

## Beam

### ► **Beam Reinforcement Definition** (continued from previous page)

#### DEFINITION OF STIRRUPS TYPE

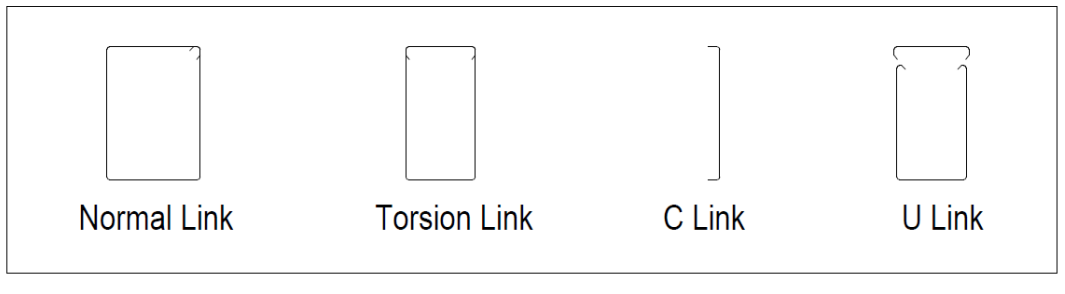

S4 – Fig 11 : Beam Annotation Stirrups

### ► **Example of Irregular Beam Section**

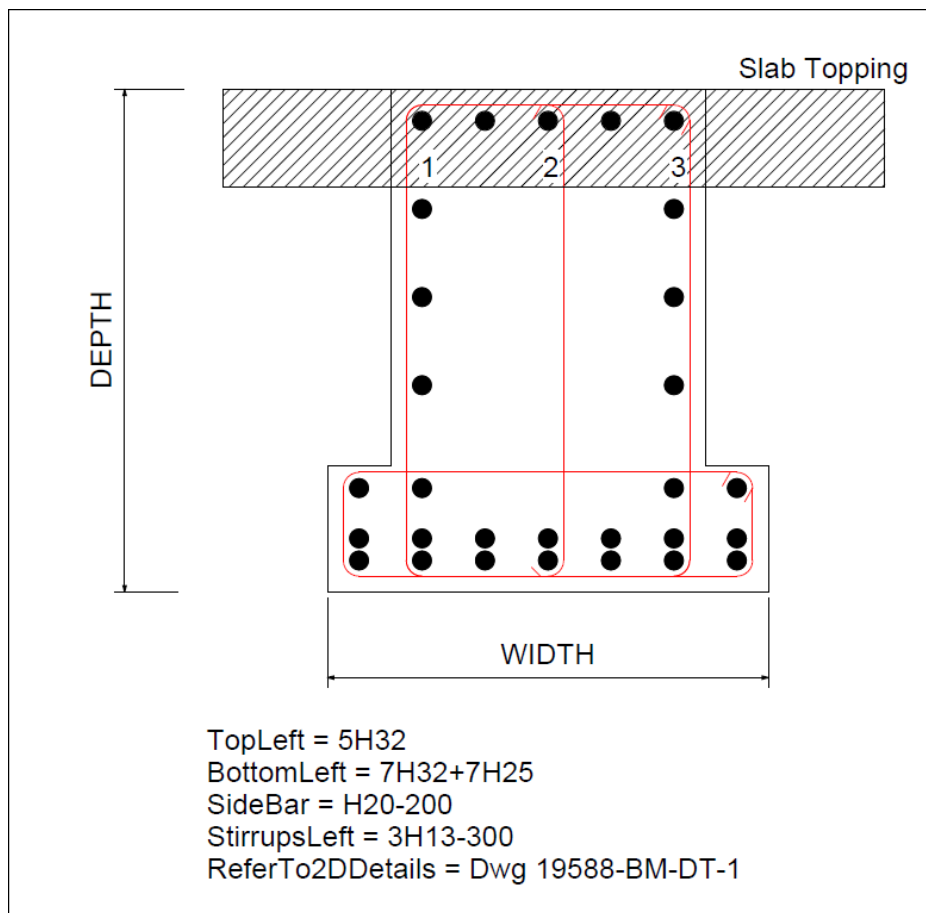

#### IRREGULAR BEAM SECTION

S4 – Fig 12 : Irregular Beam Section

# Beam

## ► By IFC Representation

IFC Entity: <b>lfcBeam</b>						
IFC SubType: N.A.						
S/N	IFC-SG Property	Property Type	Type of Elements	Unit	Input Limitation	Examples
1	BeamSpanType	Text	All beams	-	Yes	Refer to list <sup>^</sup>
2	ConstructionMethod	Text	RC beam	-	Yes	Refer to list <sup>^</sup>
3	ReferTo2DDetail	Text	When required / relevant	-	No	Dwg Number
4	ReinforcementSteelGrade	Text	RC beam	-	Yes	Refer to list <sup>^</sup>
5	SectionFabricationMethod	Text	Steel beam	-	Yes	Refer to list <sup>^</sup>
6	Depth	Length	RC beam	mm	No*	600
7	Mark	Text	All beams	-	No	HB1, VB1, B1
8	MemberSection	Text	Steel beam	-	No	RHS600x30x4, CHS500x3.0, 254x254x63kg/m
9	Width	Length	RC beam	mm	No*	300
10	BottomLeft	Text	RC beam	-	Yes	3H25
11	BottomMiddle	Text	RC beam	-	Yes	3H32+3H25+3H20
12	BottomRight	Text	RC beam	-	Yes	3H25
13	SideBar	Text	When required / relevant	-	Yes	H13-250
14	StirrupsLeft	Text	RC beam	-	Yes	4H13-300
15	StirrupsMiddle	Text	RC beam	-	Yes	4H13-300
16	StirrupsRight	Text	Optional	-	Yes	4H13-300
17	StirrupsTypeLeft	Text	Optional	-	Yes	Refer to list <sup>^</sup>
18	StirrupsTypeMiddle	Text	Optional	-	Yes	Refer to list <sup>^</sup>
19	StirrupsTypeRight	Text	Optional	-	Yes	Refer to list <sup>^</sup>
20	TopLeft	Text	RC beam	-	Yes	3H32+3H25
21	TopMiddle	Text	RC beam	-	Yes	3H25
22	TopRight	Text	RC beam	-	Yes	3H32+3H25
23	MaterialGrade	Text	All beams	-	Yes	Refer to list <sup>^</sup>
24	LeftConnectionDetail	Text	Steel beam	-	No	Detail 1
25	LeftConnectionType	Text	Steel beam	-	Yes	Refer to list <sup>^</sup>

\* Parameter is populated from the dimensions of BIM elements modelled.

<sup>^</sup> List can be found [here](#).

## Beam

### ► By IFC Representation (continued from previous page)

IFC Entity: <b>IfcBeam</b>						
IFC SubType: N.A.						
S/N	IFC-SG Property	Property Type	Type of Elements	Unit	Input Limitation	Examples
26	RightConnectionDetail	Text	Steel beam	-	No	Detail 1
27	RightConnectionType	Text	Steel beam	-	Yes	Refer to list <sup>^</sup>
28	SpliceConnection	Text	When required / relevant	-	No	Detail 3
29	Accreditation_PAS	Boolean	-	-	Yes	TRUE / FALSE
30	BeamCage	Boolean	-	-	Yes	TRUE / FALSE
31	PrefabricatedReinforcementCage	Boolean	-	-	Yes	TRUE / FALSE
32	MechanicalConnectionType	Text	-	-	No	Telescopic Beam Connector

\* Parameter is populated from the dimensions of BIM elements modelled.

<sup>^</sup> List can be found [here](#).

### ► Example of Beam (RC Beam) Structural Element Input

RC Beam (600x1200mm RC Precast Beam)	IFC Entity: <b>IfcBeam</b>		
	IFC SubType: N.A.		
	S/N	IFC-SG Property	Examples
<ul style="list-style-type: none"> <li>• Mark – 4HB52</li> <li>• Concrete grade C32/40</li> <li>• Interior span</li> <li>• Top Rebar at support 6H32</li> <li>• Bottom Rebar at support 6H20</li> <li>• Top rebar at midspan 6H20</li> <li>• Bottom Rebar at midspan 6H32+6H20</li> <li>• Stirrups at support 3 leg H10-150</li> <li>• Stirrups at midspan 3 leg H10-300</li> <li>• Sidebar H16-200</li> </ul>	1	BeamSpanType	Interior
	2	ConstructionMethod	PC
	3	ReinforcementSteelGrade	500B
	4	Depth	1200
	5	Mark	4HB52
	6	Width	600
	7	BottomLeft	6H20
	8	BottomMiddle	6H32+6H20
	9	BottomRight	6H20
	10	SideBar	H16-200

## Beam

### ► Example of Beam (RC Beam) Structural Element Input

*continued from previous page*

RC Beam (600x1200mm RC Precast Beam)	IFC Entity: <b>IfcBeam</b>			
	IFC SubType: N.A.			
<ul style="list-style-type: none"> <li>• Mark – 4HB52</li> <li>• Concrete grade C32/40</li> <li>• Interior span</li> <li>• Top Rebar at support 6H32</li> <li>• Bottom Rebar at support 6H20</li> <li>• Top rebar at midspan 6H20</li> <li>• Bottom Rebar at midspan 6H32+6H20</li> <li>• Stirrups at support 3 leg H10-150</li> <li>• Stirrups at midspan 3 leg H10-300</li> <li>• Sidebar H16-200</li> </ul>	S/N	IFC-SG Property	Examples	
		11	StirrupsLeft	3H10-150
		12	StirrupsMiddle	3H10-300
		13	StirrupsRight	3H10-150
		14	StirrupsTypeLeft	Normal+C
		15	StirrupsTypeMiddle	Normal+C
		16	StirrupsTypeRight	Interior
		17	TopLeft	6H32
		18	TopMiddle	6H20
		19	TopRight	6H32
		20	MaterialGrade	C32/40

### ► Example of Beam (Steel Beam) Structural Element Input

Steel Beam (UC254x254x63kg/m Steel Beam)	IFC Entity: <b>IfcBeam</b>			
	IFC SubType: N.A.			
<ul style="list-style-type: none"> <li>• Mark – SB1</li> <li>• Steel Grade S355 Hot Rolled</li> <li>• Cantilever Span</li> <li>• Fixed Connection to column at right part (Typical connection of SB1 to C1)</li> </ul>	S/N	IFC-SG Property	Examples	
		1	BeamSpanType	Cantilever
		2	ConstructionMethod	PF
		3	SectionFabricationMethod	Hot Rolled
		4	Mark	SB1
		5	MemberSection	UC254x254x63kg/m
		6	MaterialGrade	S355
		7	LeftConnectionDetail	-
		8	LeftConnectionType	Free
		9	RightConnectionDetail	Typical connection of SB1 to C1 on dwg 19588-ST-DT-3
	10	RightConnectionType	Fixed	

## Borehole

### ► Modelling Borehole in IFC-SG

- All the boreholes shall be modelled as per true coordinates in the IFC-SG structural model with the necessary information required as stipulated in the tables below.
  - The borehole elements shall be modelled with reasonable visibility for its location.
- The SI report for all boreholes shall be included and submitted in PDF & AGS format.

### ► By IFC Representation

IFC Entity: <b>IfcBuildingElementProxy</b>						
IFC SubType: BOREHOLE						
S/N	IFC-SG Property	Property Type	Type of Elements	Unit	Input Limitation	Examples
1	Depth	Length	All boreholes	mm	No*	14560
2	Mark	Text	All boreholes	-	No	BH1
3	SHDLevel_SPT_MoreThan_100N	Real	All boreholes	SHD Level	No	-27.5
4	SHDLevel_SPT_MoreThan_60N	Real	All boreholes	SHD Level	No	-15.0
5	TerminationLevel	Real	All boreholes	SHD Level	No	-50.5
6	TopLevel	Real	All boreholes	SHD Level	No	1.8

### ► Example of Borehole Structural Element Input

Borehole	IFC Entity: <b>IfcBuildingElementProxy</b>					
	IFC SubType: BOREHOLE					
	S/N	IFC-SG Property				Examples
<ul style="list-style-type: none"> <li>Mark – BH1</li> <li>Starting level SHD 1.50</li> <li>Termination level SHD -45.80</li> <li>Starting of soil layer with SPT&gt;60N at SHD -16.80</li> <li>Starting of soil layer with SPT&gt;100N at SHD -35.60</li> </ul>	1	Depth				47300
	2	Mark				BH1
	3	SHDLevel_SPT_MoreThan_100N				-35.6
	4	SHDLevel_SPT_MoreThan_60N				-16.8
	5	TerminationLevel				-45.8

\* Parameter is populated from the dimensions of BIM elements modelled.

## Breeching Inlet



S4 – Fig 13 : Breeching Inlet

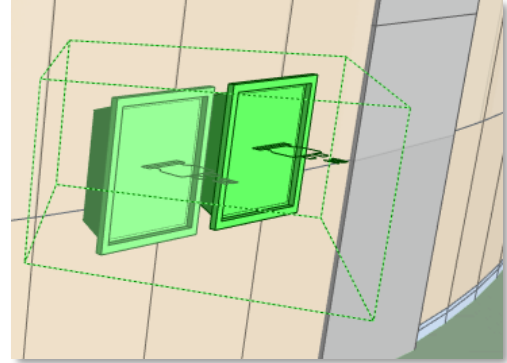

S4 – Fig 14 : Breeching Inlet

### ► By IFC Representation

<b>IFC Entity:</b> <a href="#">IfcFireSuppressionTerminal</a>						
<b>IFC SubType:</b> BREECHINGINLET						
S/N	IFC-SG Property	Property Type	Type of Elements	Unit	Input Limitation	Examples
1	Hose_NominalDiameter	Text	-	mm	No	-
2	ID	Text	-	-	No	-

#### Notes

- Besides modelling the individual Breeching Inlet as an individual component, also ensure each Breeching Inlet is exported as part of the Dry Riser, Wet Riser, Foam Sprinkler or Sprinkler [System](#) respectively.

## Building Storey

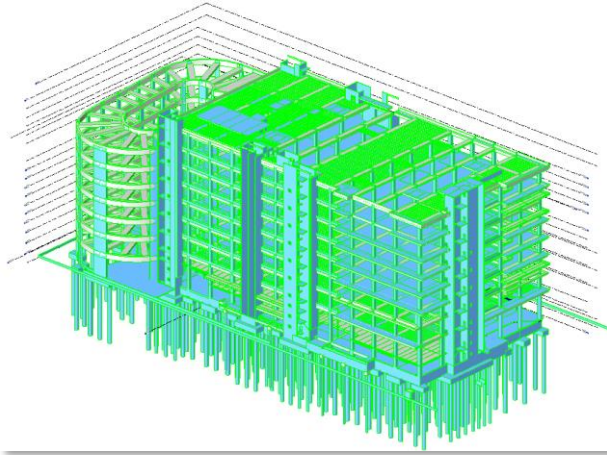

S4 – Fig 15 : Building Storey



S4 – Fig 16 : Building Storey with First Storey Plan selected

### ► Modelling Building Storey in IFC-SG

- Different levels of the building development are automatically exported to the IfcBuildingStorey entity in the IFC model.
- All disciplines must have been aligned in naming and z-value of the building storeys when geo-referencing their models for coordination
- If difficulties are encountered in the naming of a building storey due to site conditions, we encourage industry practitioners to carry out pre-consultation with relevant agencies early before modelling starts.

### ► By IFC Representation

IFC Entity: <b>IfcBuildingStorey</b>						
IFC SubType: N.A.						
S/N	IFC-SG Property	Property Type	Type of Elements	Unit	Input Limitation	Examples
1	AtticLevel	Boolean	-	-	Yes	TRUE / FALSE

#### **Notes**

- Different levels of the building development are automatically exported to the IFC model
- Roof level is required to be separately represented as a property to meet URA requirements



# Ceiling

## ► By IFC Representation

IFC Entity: <a href="#">IfcCovering</a>						
IFC SubType: CEILING						
S/N	IFC-SG Property	Property Type	Type of Elements	Unit	Input Limitation	Examples
1	FireRating	Text	-	-	No	1 hr, 4hr
2	Material	Text	-	-	No	Sand, Corey Dust, Granite Dust, Gravel, Crusher Run, Recycled Aggregates, Intumescent Paint, Steel, Timber, Engineered Timber, Concrete, Wood, Brick, Reinforced Concrete, MET, Galvanized Mild Steel Heavy Duty, Plastic, Plastered, Fair-Faced Brickwall, Samples of Concrete Elements

# Column

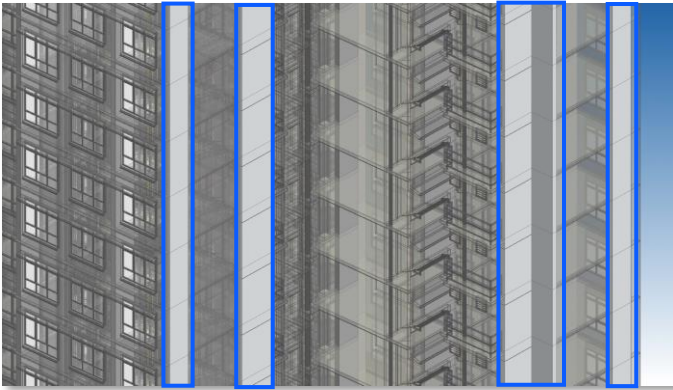

S4 – Fig 17: Columns in relation to the Building

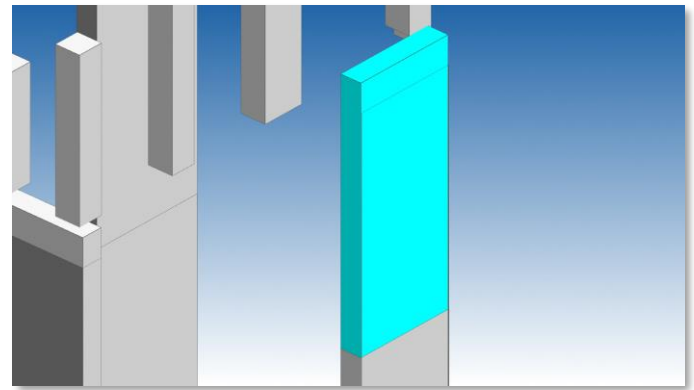

S4 – Fig 18: Column

## ► Modelling Column in IFC-SG

- All the column elements shall be modelled in IFC-SG model with the necessary information required as stipulated in the tables below.
  - Typical columns are allowed to have same marks and design information. The marks and design information have to be embedded in every column element.
  - Multiple columns elements shall be modelled from support to support (storey to storey) for continuous column.
  - Column working load is required for 1<sup>st</sup> storey column only.
- 2D detail drawings are allowed for any irregular or complex column section (e.g. L shape column, inclined column, composite column, cold-form steel column, etc.) with the indication of drawing number in the IFC-SG parameter “ReferTo2DDetail”.

## ► Column Dimension and Reinforcement Definition

Column Dimension and Reinforcement Definition	
<b>1</b>	The breadth is referring to the longest side of a rectangular column while width is referring to the shorter side of a rectangular column, despite of the column orientation.
<b>2</b>	QP may substantiate a set of 2D column schedule drawings to present the orientation and arrangement of column reinforcement for illustration.
<b>3</b>	The input for MainRebar shall be “XXHXX” while “H” is a must, 1 <sup>st</sup> XX is number of longitudinal reinforcement & 2 <sup>nd</sup> XX is the reinforcement diameter. <ul style="list-style-type: none"> <li>• Use ‘+’ for bundle column reinforcement (e.g. 12H32+12H25)</li> </ul> <div style="text-align: center; margin-top: 10px;"> </div>

# Column

## ► Column Dimension and Reinforcement Definition (continued from previous page)

Column Dimension and Reinforcement Definition	
4	<p>The input for Stirrups shall be “XHXX-XXX” while “H” is a must, X is number of legs for transverse reinforcement, XX are the reinforcement diameter and XXX is the spacing of transverse reinforcement (e.g. 4H10-150).</p> <ul style="list-style-type: none"> <li>Use ‘+’ for more than 1 layer of reinforcement (e.g. 4H10-100+4H8-100, [4 denotes 4 legs])</li> </ul> <div style="text-align: center;"> <p>XXHXX-XXX</p> </div>
5	<p>Type of the column stirrup (Normal link, U-link, C-link or torsion link) shall be indicated in the parameters called “StirrupType” based on beam part. Limitation of inputs for this parameter is applied. Please refer to <a href="#">list</a> of input. This parameter is optional for input.</p>

## ► Example of Column Sections

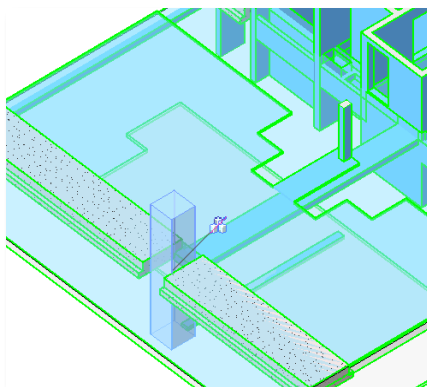
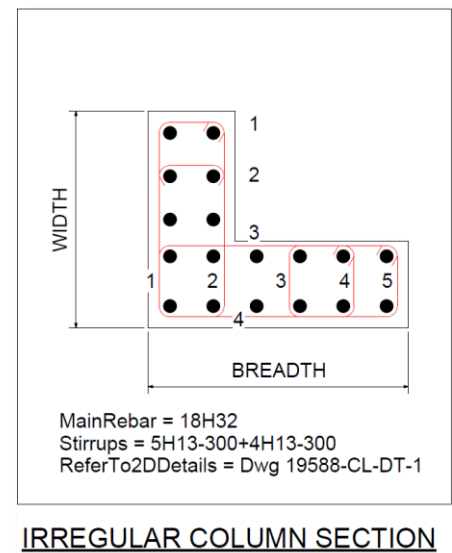
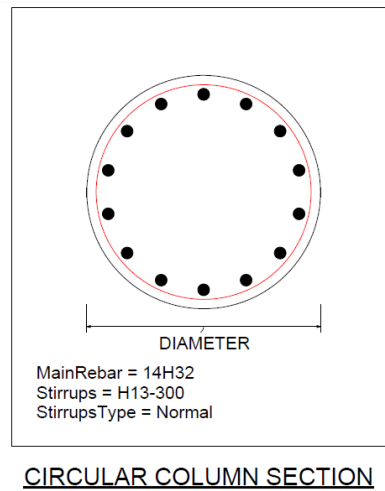
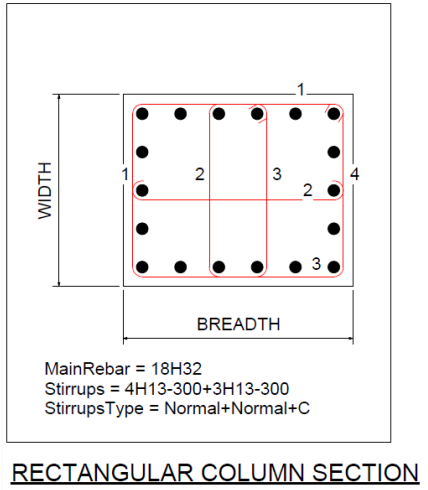

S4 – Fig 19: Rectangular Column

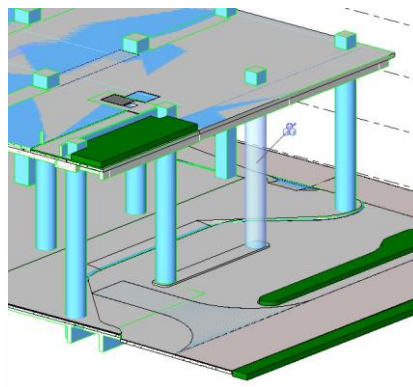

S4 – Fig 20: Circular Column

S4 – Fig 21: Irregular Column Section

# Column

## ► By IFC Representation

IFC Entity: <b>IfcColumn</b>						
IFC SubType: N.A.						
S/N	IFC-SG Property	Property Type	Type of Elements	Unit	Input Limitation	Examples
1	ConstructionMethod	Text	RC column	-	Yes	Refer to list <sup>^</sup>
2	ReferTo2DDetail	Text	When required / relevant	-	No	Dwg Number
3	ReinforcementSteelGrade	Text	RC column	-	Yes	Refer to list <sup>^</sup>
4	SectionFabricationMethod	Text	Steel column	-	Yes	Refer to list <sup>^</sup>
5	Breadth	Length	RC column	mm	No*	300
6	Diameter	Length	When required / relevant	mm	No*	600
7	EndStorey	Text	All columns	-	No	2 <sup>nd</sup> Storey, Roof Storey
8	Mark	Text	All columns	-	No	C1, TC1
9	MemberSection	Text	Steel column	-	No	RHS600x30x4, CHS500x3.0, 254x254x63kg/m
10	StartingStorey	Text	All columns	-	No	1 <sup>st</sup> Storey, Lower Roof Storey
11	Width	Length	RC column	mm	No*	600
12	MainRebar	Text	RC column	-	Yes	6H32+6H25
13	Stirrups	Text	RC column	-	Yes	4H13-300
14	StirrupsType	Text	Optional	-	Yes	Refer to list <sup>^</sup>
15	WorkingLoad_DA1-1	Integer	When required / relevant	kN	No	1234
16	WorkingLoad_DA1-2	Integer	When required / relevant	kN	No	1234
17	MaterialGrade	Text	All columns	-	Yes	Refer to list <sup>^</sup>
18	ConnectionDetailsBottom	Text	Steel column	-	Yes	Detail 1
19	ConnectionDetailsTop	Text	Steel column	-	Yes	Detail 1
20	ConnectionTypeBottom	Text	Steel column	-	No	Refer to list <sup>^</sup>
21	ConnectionTypeTop	Text	Steel column	-	No	Refer to list <sup>^</sup>
22	SpliceDetail	Text	When required / relevant	-	No	Detail 3
23	Accreditation_PAS	Boolean	-	-	Yes	TRUE / FALSE
24	ColumnCage	Boolean	-	-	Yes	TRUE / FALSE
25	PrefabricatedReinforcementCage	Boolean	-	-	Yes	TRUE / FALSE
26	MechanicalConnectionType	Text	-	-	No	Column Shoes
27	ArrangementType	Text	-	-	No	Multi-Tier

## Column

### ► Example of Column (RC CIS Column) Structural Element Input

RC Column (600x600mm RC Cast-In-Situ Column)	IFC Entity: <b>IfcColumn</b>		
	IFC SubType: N.A.		
<ul style="list-style-type: none"> <li>Mark – C2</li> <li>Concrete grade C32/40</li> <li>From 1<sup>st</sup> storey to 2<sup>nd</sup> storey</li> <li>Main rebar 8H20</li> <li>2 nos H10-300 link (total 4 legs)</li> <li>Load for DA1-1: 4536kN</li> <li>Load for DA1-2: 3864kN</li> </ul>	S/N	IFC-SG Property	Examples
	1	ConstructionMethod	CIS
	2	ReinforcementSteelGrade	500B
	3	Breadth	600
	4	EndStorey	2nd storey
	5	Mark	C2
	6	StartingStorey	1st storey
	7	Width	600
	8	MainRebar	8H20
	9	Stirrups	4H10-300
	10	StirrupsType	Normal
	11	WorkingLoad_DA1-1	4536
	12	WorkingLoad_DA1-2	3864
13	MaterialGrade	C32/40	

### ► Example of Column (Steel Column) Structural Element Input

Steel Column (UC305x305x118kg/m Steel Column)	IFC Entity: <b>IfcColumn</b>		
	IFC SubType: N.A.		
<ul style="list-style-type: none"> <li>Mark – SC1</li> <li>Steel grade S355 hot rolled</li> <li>From 6<sup>th</sup> storey to roof storey</li> <li>Pinned connection to RC column at bottom part (Typical SC1 baseplate details) and support a steel frame (Typical connection of SB1 to SC1)</li> </ul>	S/N	IFC-SG Property	Examples
	1	ConstructionMethod	PF
	2	SectionFabricationMethod	Hot Rolled
	3	EndStorey	Roof Storey
	4	Mark	SC1
	5	MemberSection	UC305x305x118kg/m
	6	StartingStorey	6 <sup>th</sup> Storey
	7	MaterialGrade	S355
	8	ConnectionDetailsBottom	Pinned
	9	ConnectionDetailsTop	Pinned
	10	ConnectionTypeBottom	Typical SC1 baseplate details on dwg 19588-ST-DT-6
11	ConnectionTypeTop	Typical connection of SB1 to SC1 on dwg 19588-ST-DT-6	

## Control Element

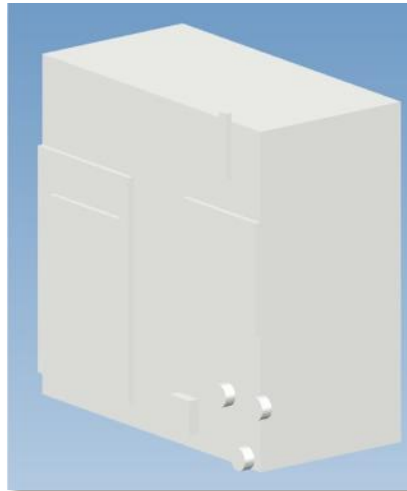

S4 – Fig 22 : Control Panel

### ► By IFC Representation

IFC Entity: <b>IfcUnitaryControlElement</b>						
IFC SubType: CONTROLPANEL						
S/N	IFC-SG Property	Property Type	Type of Elements	Unit	Input Limitation	Examples
1	Purpose	Text	-	-	No	Main Panel, Sub Panel
2	PWCS_Flushing	Boolean	-	-	Yes	TRUE / FALSE

# Culvert

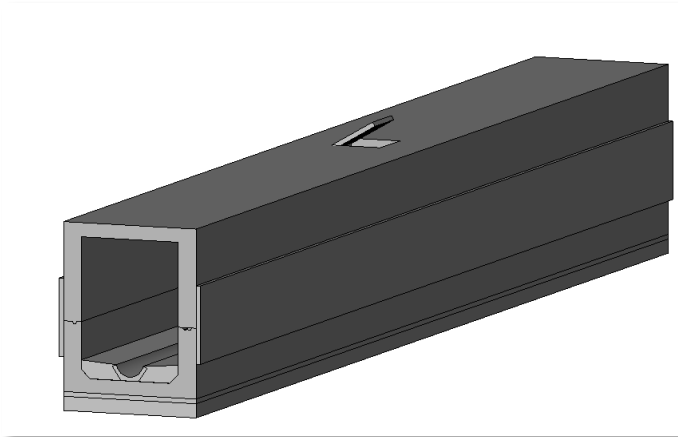

S4 – Fig 23 : Culvert

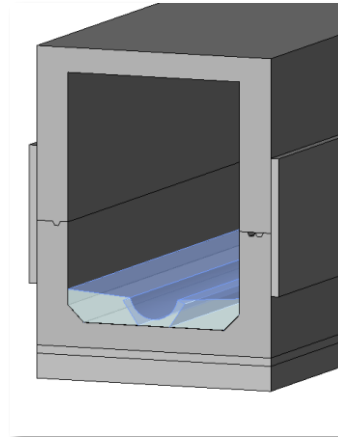

S4 – Fig 24 : Culvert

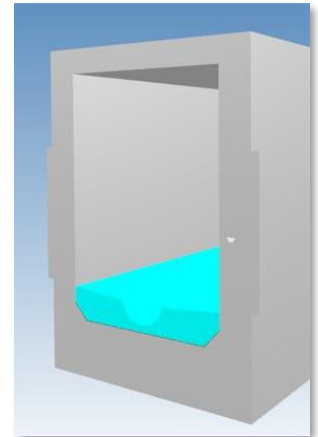

S4 – Fig 25 : Culvert

## ► By IFC Representation

IFC Entity: <b>IfcCivilElement</b>						
IFC SubType: CULVERT, ENTRANCECULVERT, CROSSCULVERT, EXTERNALDRAIN, COMMONDRAIN, INTERNALDRAIN, OUTLETDRAIN, ROADSIDEDRAIN, TRENCH						
S/N	IFC-SG Property	Property Type	Type of Elements	Unit	Input Limitation	Examples
1	LoadBearing	Boolean	-	-	Yes	TRUE / FALSE
2	Gradient	Text	-	-	No	-
3	Diameter	Length	-	mm	No	-
4	Height	Length	-	mm	No	-
5	Length	Length	-	mm	No	-
6	Thickness	Length	-	mm	No	-
7	Width	Length	-	mm	No	-
8	Footpath	Boolean	-	-	No	-
9	Material	Text	-	-	No	-

IFC Entity: <b>IfcBuildingElementProxy</b>						
IFC SubType: DROPINLETCHAMBER						
S/N	IFC-SG Property	Property Type	Type of Elements	Unit	Input Limitation	Examples
-	-	-	-	-	-	-

## Curtain Wall

### ► By IFC Representation

IFC Entity: <a href="#">IfcCurtainWall</a>						
IFC SubType: N.A.						
S/N	IFC-SG Property	Property Type	Type of Elements	Unit	Input Limitation	Examples
-	-	-	-	-	-	-



# Damper

## ► By IFC Representation

<b>IFC Entity:</b> <a href="#">IfcDamper</a>						
<b>IFC SubType:</b> FIREDAMPER, FIRESMOKEDAMPER, SMOKEDAMPER						
S/N	IFC-SG Property	Property Type	Type of Elements	Unit	Input Limitation	Examples
1	FireRating	Text	-	-	Yes	30min / 60min / 90min / 120min / 150min / 180min / 210min / 240min

### Notes

- Modelling Damper is voluntary.
- Refer [here](#) for fire safety equipment / provisions that need not be modelled in full and can be represented by suitable modelling objects / components.

## Distribution Chamber

### ► Modelling Distribution Chamber in IFC-SG

- Distribution Chambers include Inspection Chambers, Manholes, Meter Chambers, Sampling Sumps and Sumps.
  - Refer to other Distribution Chambers in IFC SubTypes on the next page

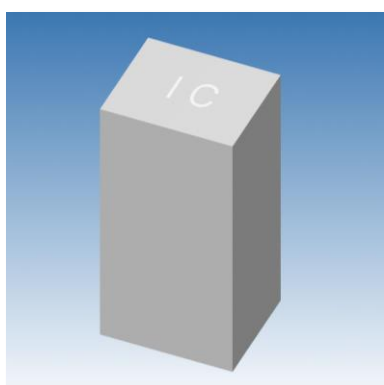

S4 – Fig 26: Inspection Chamber

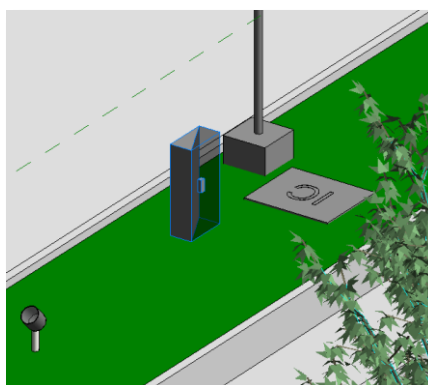

S4 – Fig 27: Inspection Chamber

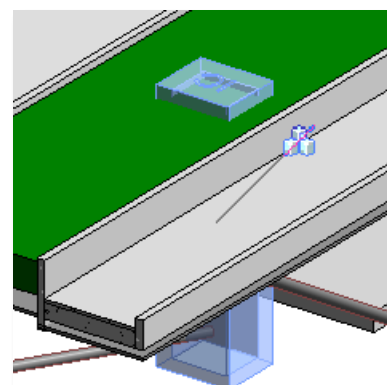

S4 – Fig 28: Inspection Chamber

### ► By IFC Representation

IFC Entity: <b>IfcDistributionChamberElement</b>						
IFC SubType: INSPECTIONCHAMBER, PWCSINSPECTIONCHAMBER, MANHOLE, PWCSMANHOLE, METERCHAMBER, SCREENCHAMBER, SUMP, TRENCH, SAMPLINGSUMP						
S/N	IFC-SG Property	Property Type	Type of Elements	Unit	Input Limitation	Examples
1	TopLevel	Real	-	SHD m	No	-50, 3.423
2	InvertLevel	Real	-	SHD m	No	-
3	Diameter	Length	-	mm	No	-
4	Depth	Length	-	mm	No	-
5	Height	Length	-	mm	No	-
6	Length	Length	-	mm	No	-
7	Width	Length	-	mm	No	-
8	Material	Text	-	-	No	-
9	TradeEffluent	Boolean	-	-	Yes	TRUE / FALSE
10	ID	Text	-	-	No	
11	Status	Text	-	-	No	Temporary, Demolished, Existing, Proposed, To Be Removed, To Be Transplanted, Abandoned, New

## Distribution Chamber

### ► By IFC Representation (continued from previous page)

<b>IFC Entity:</b> <a href="#">IfcCovering</a>						
<b>IFC SubType:</b> PWCSINSPECTIONCHAMBERCOVER, PWCSMANHOLECOVER						
S/N	IFC-SG Property	Property Type	Type of Elements	Unit	Input Limitation	Examples
1	Watertight	Boolean	-	-	Yes	TRUE / FALSE
2	ExternalReference	Text	-	-	No	SS 30 Manhole Tops and Surface-box Tops

#### Notes

- Sanitary drain-lines are to be submitted as schematic and/or 2D drawings. If industry would like to submit in 3D, it is optional and will also be accepted.

# Door

## ► Modelling Door in IFC-SG

- All the door elements must indicate “ClearHeight” in its properties, to facilitate headroom checks.

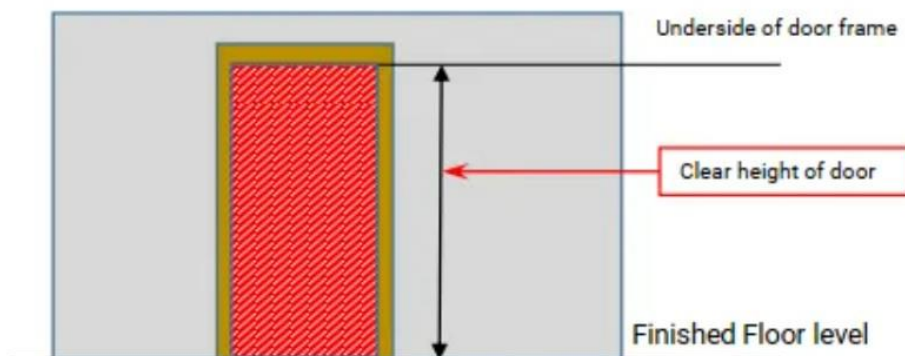

## ► By IFC Representation

IFC Entity: <b>IfcDoor</b>						
IFC SubType: DOOR, GATE, ACCESSHATCH, BLASTDOOR, ROLLERSHUTTER						
S/N	IFC-SG Property	Property Type	Type of Elements	Unit	Input Limitation	Examples
1	ClearWidth	Length	-	mm	No	1200
2	ClearHeight	Length	-	mm	No	N.A.
3	FireExit	Boolean	-	-	Yes	TRUE / FALSE
4	FireRating	Text	-	hr	No	½-hr , 1-hr etc.
5	Hardware	Boolean	-	-	Yes	TRUE / FALSE
6	MainEntrance	Boolean	-	-	Yes	TRUE / FALSE
7	OneWayLockingDevice	Boolean	-	-	Yes	TRUE / FALSE
8	OperationType	Text	-	-	No	Pls refer to the next page
9	OverallWidth	Length	-	mm	No	-
10	PowerOperated	Boolean	-	-	Yes	TRUE / FALSE
11	SelfClosing	Boolean	-	-	Yes	TRUE / FALSE
12	Thickness	Length	-	mm	No	N.A.
13	VisionPanel	Boolean	-	-	Yes	TRUE / FALSE
14	Material	Text	-	-	No	-
15	FireAccessOpening	Boolean	-	-	Yes	TRUE / FALSE

# Door

## ► Door Operation Types

To facilitate viewing of door swings and other operation movements in IFC format, inputs or values for the “OperationType” parameter should be provided with reference to the table below. More info can be found at <https://standards.buildingsmart.org/IFC/RELEASE/IFC4/ADD1/HTML/schema/ifcsharedbldgelements/lexical/ifcdoortypeoperationenum.htm>

“OperationType” parameter values	Description
SINGLE_SWING_LEFT	<ul style="list-style-type: none"> <li>Door with one panel that opens (swings) to the left.</li> <li>The hinges are on the left side as viewed in the direction of the positive y-axis</li> </ul>
SINGLE_SWING_RIGHT	<ul style="list-style-type: none"> <li>Door with one panel that opens (swings) to the right.</li> <li>The hinges are on the right side as viewed in the direction of the positive y-axis</li> </ul>
DOUBLE_DOOR_SINGLE_SWING	<ul style="list-style-type: none"> <li>Door with two panels, one opens (swings) to the left, the other opens (swings) to the right</li> </ul>
DOUBLE_DOOR_SINGLE_SWING_OPPosite_LEFT	<ul style="list-style-type: none"> <li>Door with two panels that both open to the left, one panel swings in one direction and the other panel swings in the opposite direction</li> </ul>
DOUBLE_DOOR_SINGLE_SWING_OPPosite_RIGHT	<ul style="list-style-type: none"> <li>Door with two panels that both open to the right, one panel swings in one direction and the other panel swings in the opposite direction</li> </ul>
DOUBLE_SWING_LEFT	<ul style="list-style-type: none"> <li>Door with one panel that swings in both directions and to the left in the main traffic direction, also called double acting door</li> </ul>
DOUBLE_SWING_RIGHT	<ul style="list-style-type: none"> <li>Door with one panel that swings in both directions and to the right in the main traffic direction, also called double acting door</li> </ul>
DOUBLE_DOOR_DOUBLE_SWING	<ul style="list-style-type: none"> <li>Door with two panels</li> <li>One panel swings in both directions and to the right in the main traffic direction</li> <li>The other panel swings also in both directions and to the left in the main traffic direction</li> </ul>
SLIDING_TO_LEFT	<ul style="list-style-type: none"> <li>Door with one panel that is sliding to the left</li> </ul>
SLIDING_TO_RIGHT	<ul style="list-style-type: none"> <li>Door with one panel that is sliding to the right</li> </ul>
DOUBLE_DOOR_SLIDING	<ul style="list-style-type: none"> <li>Door with two panels</li> <li>One is sliding to the left, the other is sliding to the right</li> </ul>
FOLDING_TO_LEFT	<ul style="list-style-type: none"> <li>Door with one panel that is folding to the left</li> </ul>
FOLDING_TO_RIGHT	<ul style="list-style-type: none"> <li>Door with one panel that is folding to the right</li> </ul>
DOUBLE_DOOR_FOLDING	<ul style="list-style-type: none"> <li>Door with two panels</li> <li>One is folding to the left, the other is folding to the right</li> </ul>
REVOLVING	<ul style="list-style-type: none"> <li>An entrance door consisting of four leaves set in a form of a cross</li> <li>Revolves around a central vertical axis</li> </ul>
ROLLING UP	<ul style="list-style-type: none"> <li>Door that opens by rolling up</li> </ul>
SWING_FIXED_LEFT	<ul style="list-style-type: none"> <li>Door with one panel that opens (swings) to the left and one fixed panel</li> <li>The hinges of the swinging panel are on the left side as viewed in the direction of the positive y-axis</li> </ul>
SWING_FIXED_RIGHT	<ul style="list-style-type: none"> <li>Door with one panel that opens (swings) to the right and one fixed panel</li> <li>The hinges of the swinging panel are on the right side as viewed in the direction of the positive y-axis</li> </ul>

## Door

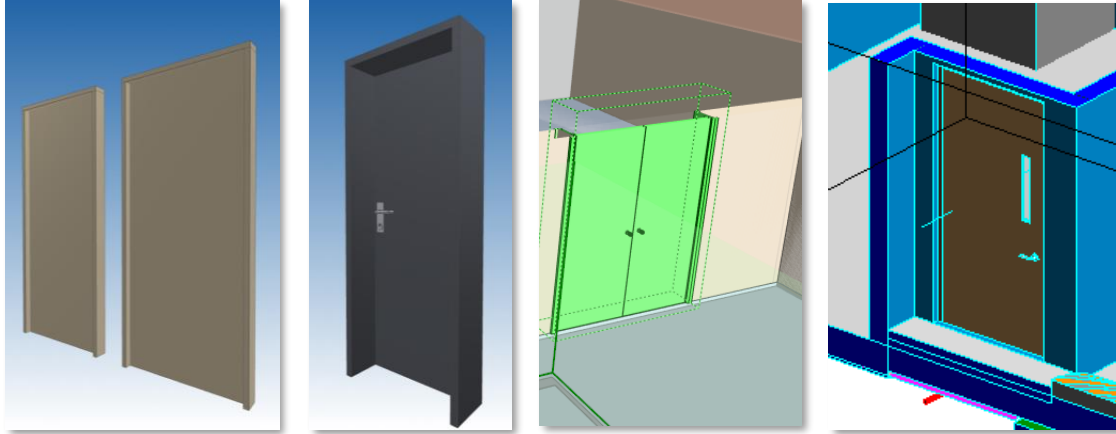

S4 – Fig 29 to 32 : Doors

## Earthworks

### ► By IFC Representation

<b>IFC Entity:</b> <a href="#">IfcGeographicElement</a>						
<b>IFC SubType:</b> TERRAIN, EXISTINGEARTHWORKS, PROPOSEDEARTHWORKS						
S/N	IFC-SG Property	Property Type	Type of Elements	Unit	Input Limitation	Examples
1	Area	Area	-	m <sup>2</sup>	No	-

# Escalator

## ► By IFC Representation

<b>IFC Entity:</b> <a href="#">IfcTransportElement</a>							
<b>IFC SubType:</b> ESCALATOR							
S/N	IFC-SG Property	IFC-SG PropertySet	Property Type	Type of Elements	Unit	Input Limitation	Examples
-	-	-	-	-	-	-	-



## Family-Friendly Furniture

### ► By IFC Representation

<b>IFC Entity:</b> <a href="#">IfcFurniture</a>						
<b>IFC SubType:</b> CHANGINGBED, CHILDPROTECTIONSEAT, DIAPERCHANGINGTABLE						
S/N	IFC-SG Property	Property Type	Type of Elements	Unit	Input Limitation	Examples
-	-	-	-	-	-	-

# Finishes

## ► By IFC Representation

<b>IFC Entity:</b> <a href="#">IfcCovering</a>						
<b>IFC SubType:</b> CLADDING, FIRECURTAIN, FLOORING, PIPESLEEVE, SOFFIT						
S/N	IFC-SG Property	Property Type	Type of Elements	Unit	Input Limitation	Examples
1	FireRating	Text	-	-	No	-
2	Material	Text	-	-	No	-

<b>IFC Entity:</b> <a href="#">IfcBuildingElementProxy</a>						
<b>IFC SubType:</b> TACTILETILE						
S/N	IFC-SG Property	Property Type	Type of Elements	Unit	Input Limitation	Examples
-	-	-	-	-	-	-

- Note: Tactile Tiles are included as part of the [Footpath component](#) only

## Fire Access Opening

### ► By IFC Representation

IFC Entity: <a href="#">IfcOpeningElement</a> , <a href="#">IfcDoor</a> , <a href="#">IfcWindow</a>						
IFC SubType: OPENING						
S/N	IFC-SG Property	Property Type	Type of Elements	Unit	Input Limitation	Examples
1	FireAccessOpening	Boolean	-	-	Yes	TRUE / FALSE

### ► Modelling Fire Access Opening in IFC-SG

- This component can be modelled using [IfcOpeningElement](#), [IfcDoor](#) or [IfcWindow](#), where relevant.

# Fire Alarm

## ► Modelling Fire Alarm in IFC-SG

- For Manual Fire Alarm, it will be shown together with BP at Construction Gateway (G2) as it is under the purview of the Architect.
- Design of automatic fire alarm system will be submitted in Independent Gateway as it is submitted by the Professional Engineer (optional in 3D).

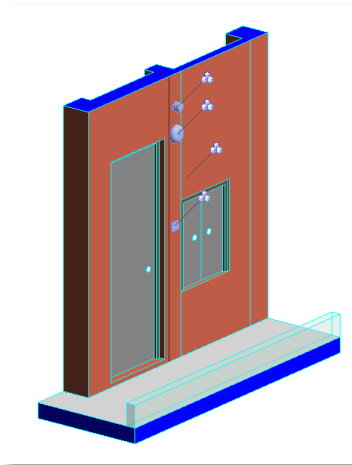

S4 – Fig 33 : Fire Alarm

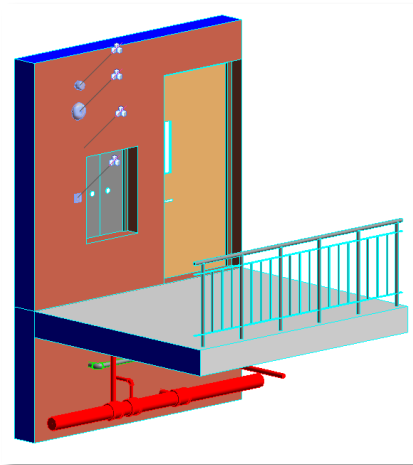

S4 – Fig 34 : Fire Alarm



S4 – Fig 35 : Fire Alarm

## ► By IFC Representation

<b>IFC Entity:</b> <a href="#">IfcAlarm</a>						
<b>IFC SubType:</b> FIREALARMPANEL, MANUALALARMCALLPOINT, VISUALALARM, SOUNDER, HOMEFIREALARMDEVICE						
S/N	IFC-SG Property	Property Type	Type of Elements	Unit	Input Limitation	Examples
-	-	-	-	-	-	-

# Fire Extinguisher

## ► By IFC Representation

<b>IFC Entity:</b> <a href="#">IfcBuildingElementProxy</a>						
<b>IFC SubType:</b> PORTABLEFIREEXTINGUISHER						
S/N	IFC-SG Property	Property Type	Type of Elements	Unit	Input Limitation	Examples
1	FireExtinguisherRating	Text	-	-	No	-

## Fire Hydrant



S4 – Fig 36 : Fire Hydrant

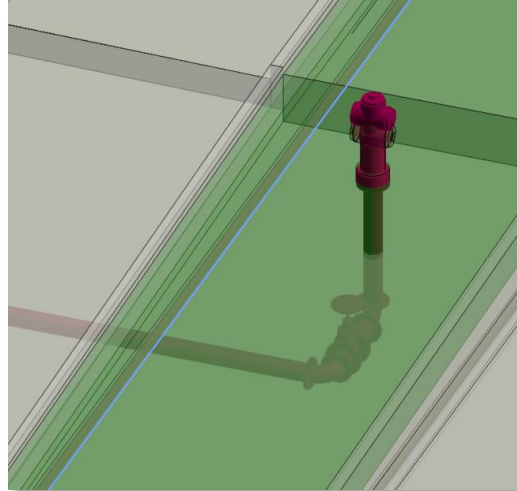

S4 – Fig 37 : Fire Hydrant

### ► Modelling Fire Hydrant in IFC-SG

- Details for technical clearance is not part of Gateway approval and is to be submitted as individual SCDF clearance in 2D. 3D is optional.

### ► By IFC Representation

IFC Entity: <b>lfcFireSuppressionTerminal</b>						
IFC SubType: FIREHYDRANT						
S/N	IFC-SG Property	Property Type	Type of Elements	Unit	Input Limitation	Examples
1	ID	Text	-	-	-	N.A.
2	Private	Boolean	-	-	Yes	TRUE / FALSE
3	Public	Boolean	-	-	Yes	TRUE / FALSE

## Foam Inlet / Outlet

### ► By IFC Representation

<b>IFC Entity:</b> <a href="#">IfcFireSuppressionTerminal</a>							
<b>IFC SubType:</b> FOAMINLET, FOAMOUTLET							
S/N	IFC-SG Property	IFC-SG PropertySet	Property Type	Type of Elements	Unit	Input Limitation	Examples
-	-	-	-	-	-	-	-

# Footpath

## ► By IFC Representation

<b>IFC Entity: <a href="#">IfcCivilElement</a></b>						
<b>IFC SubType: FOOTPATH</b>						
S/N	IFC-SG Property	Property Type	Type of Elements	Unit	Input Limitation	Examples
1	Material	Text	-	-	-	-
2	Width	Length	-	-	-	-

<b>IFC Entity: <a href="#">IfcBuildingElementProxy</a></b>						
<b>IFC SubType: TACTILETILE</b>						
S/N	IFC-SG Property	Property Type	Type of Elements	Unit	Input Limitation	Examples
-	-	-	-	-	-	-



## Footing / Pilecap

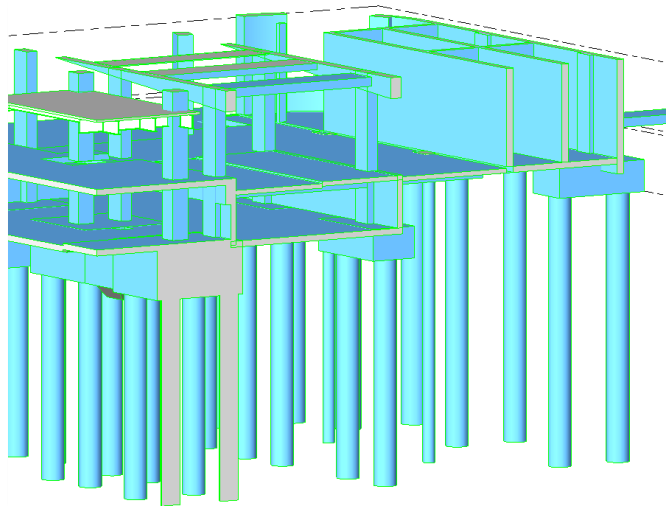

S4 – Fig 38 : Footing / Pilecap

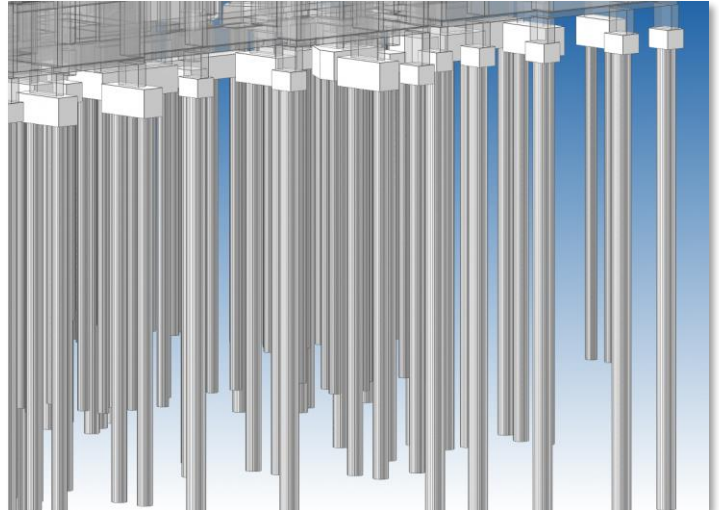

S4 – Fig 39 : Footing / Pilecap

### ► Modelling Footing / Pilecap in IFC-SG

- All the footing / pilecap elements shall be modelled as independent elements\* in IFC-SG model with the necessary information required as stipulated in the tables below.
  - For footing and pilecap with the same foundation design, they are allowed to have same marks and design information. All marks and design information have to be embedded in every footing / pilecap element.
- 2D detail drawings are allowed for any irregular or complex footing/pilecap design (e.g. 3 pile group, stair core pile group, etc.) with the indication of drawing number in the IFC-SG parameter “ReferTo2DDetail”.
- The following pile-related parameters do not need to be provided for individual piles. Instead, they are to be provided in general (refer to the “Project Information” component in Section 4)
  - Pile Model Factor, Shaft R4 Design Factor, End Bearing R4 Design Factor
  - Number of ULT Tests, Number of Working Load Tests – Maintained Load Tests and Rapid Load Tests, Number of Non Destructive Test Piles

*\*Independent elements refers to elements with no combining or grouping of piles, pilecaps, footings or columns as one family type or generic element*

# Footing / Pilecap

## ► Footing / Pilecap Dimension and Reinforcement Definition

Footing / Pilecap Dimension and Reinforcement Definition	
1	The breadth is referring to the longest side of a footing / pilecap while width is referring to the shorter side of a footing / pilecap, despite of its element orientation.
2	<p>The input for TopMain, TopDistribution, BottomMain &amp; BottomDistributions shall be "HXX-XXX" while "H" is a must, XX is the longitudinal reinforcement diameter and XXX is the spacing of longitudinal reinforcement.</p> <ul style="list-style-type: none"> <li>Use '+' for more than 1 layer of reinforcement (e.g. H32-150+H25-150)</li> </ul> <div style="text-align: center;"> </div>
3	<p>The input for Stirrups shall be "HXX-XXX-XXX" while "H" is a must, XX are the transverse reinforcement diameter and XXX is the spacing of transverse reinforcement.</p> <ul style="list-style-type: none"> <li>Indicate the longitudinal spacing (main direction) and follow with transverse spacing (distribution direction) (e.g. H8-100-100)</li> </ul> <div style="text-align: center;"> </div>

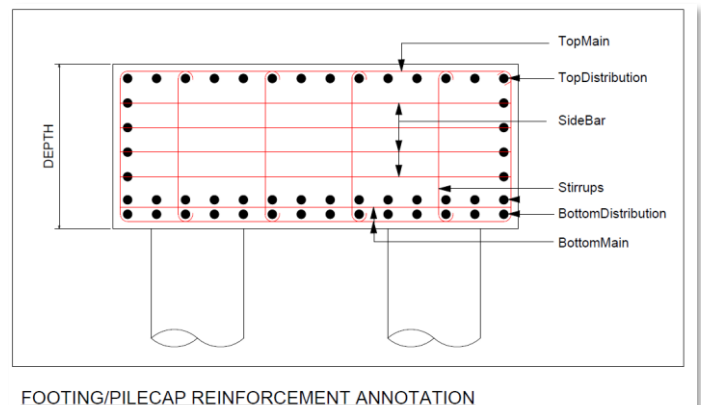
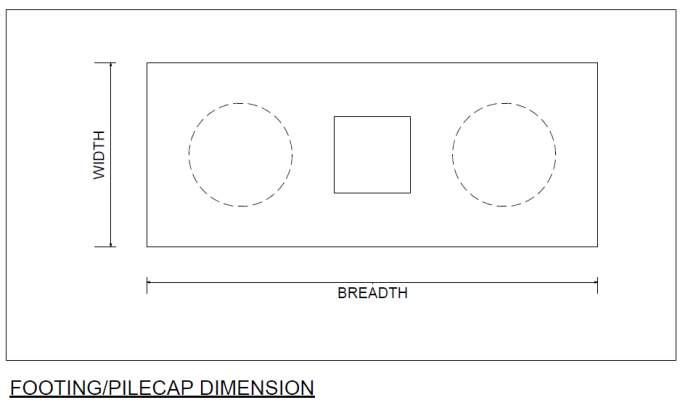

S4 – Fig 40 : Dimension Definitions for Footing / Pilecap

S4 – Fig 41 : Dimension Definitions for Footing / Pilecap

## Footing / Pilecap

### ► By IFC Representation

IFC Entity: <b>IfcFooting</b>						
IFC SubType: N.A.						
S/N	IFC-SG Property	Property Type	Type of Elements	Unit	Input Limitation	Examples
1	DA1-1_BearingCapacity	Integer	All footings	kN/m <sup>2</sup>	No	150
2	DA1-2_BearingCapacity	Integer	All footings	kN/m <sup>2</sup>	No	120
3	ReferTo2DDetail	Text	When required / relevant	-	No	Dwg Number
4	ReinforcementSteelGrade	Text	All footings & pilecap	-	Yes	Refer to list <sup>^</sup>
5	SoilVerificationTest	Text	When required / relevant	-	No	2 nos Plate load Test
6	Breadth	Length	All footings & pilecap	mm	No*	6200
7	Depth	Length	All footings & pilecap	mm	No*	300
8	Mark	Text	All footings & pilecap	-	No	F1, F2, PC1, PC2, PC4_1
9	Width	Length	All footings & pilecap	mm	No*	300
10	BottomDistribution	Text	All footings & pilecap	-	Yes	H16-150
11	BottomMain	Text	All footings & pilecap	-	Yes	H25-150
12	SideBar	Text	All footings & pilecap	-	Yes	H13-250
13	Stirrups	Text	When required / relevant	-	Yes	H13-200-300
14	StirrupsType	Text	Optional	-	Yes	Refer to list <sup>^</sup>
15	TopDistribution	Text	All footings & pilecap	-	Yes	H16-150
16	TopMain	Text	All footings & pilecap	-	Yes	H25-150
17	WorkingLoad_DA1-1	Integer	All footings	kN	No	4321
18	WorkingLoad_DA1-2	Integer	All footings	kN	No	4321
19	MaterialGrade	Text	All footings & pilecap	-	Yes	Refer to list <sup>^</sup>

\* Parameter is populated from the dimensions of BIM elements modelled.

<sup>^</sup> List can be found [here](#).

## Footing / Pilecap

### ► Example of Footing / Pilecap (RC Pile Cap) Structural Element Input

5900 x 1900 x 1250mm Depth Pilecap	IFC Entity: <b>lfcFooting</b>		
	IFC SubType: N.A.		
<ul style="list-style-type: none"> <li>• Mark – 2PC1600A</li> <li>• Concrete grade C32/40</li> <li>• Top Rebar (main) H32-200</li> <li>• Top Rebar (distribution) H20-200</li> <li>• Bottom Rebar (main) H32-200+H16-200</li> <li>• Bottom Rebar (distribution) H20-200</li> <li>• Binder bar H16-150</li> </ul>	S/N	IFC-SG Property	Examples
	1	ReinforcementSteelGrade	500B
	2	Breadth	5900
	3	Depth	1250
	4	Mark	2PC1600A
	5	Width	1900
	6	BottomDistribution	H20-200
	7	BottomMain	H32-200+H16-200
	8	SideBar	H16-150
	9	TopDistribution	H20-200
	10	TopMain	H32-200
11	MaterialGrade	C32/40	

## Footing / Pilecap

### ► Example of Footing / Pilecap (RC Footing) Element Input

1250 x 800 x 450mm Depth Footing	IFC Entity: <b>IcfFooting</b>		
	IFC SubType: N.A.		
	S/N	IFC-SG Property	Examples
<ul style="list-style-type: none"> <li>• Mark – F2</li> <li>• Concrete grade C32/40</li> <li>• Top Rebar (main) H13-200</li> <li>• Top Rebar (distribution) H10-200</li> <li>• Bottom Rebar (main) H16-200</li> <li>• Bottom Rebar (distribution) H10-200</li> <li>• Binder bar H10-200</li> <li>• Allowable soil bearing pressure                             <ul style="list-style-type: none"> <li>○ DA1-C1: 150kN/m<sup>2</sup></li> <li>○ DA1-C2: 120kN/m<sup>2</sup></li> </ul> </li> <li>• 1 no of plate load test (for whole project)</li> <li>• Working Load (DA1-1) 1286kN</li> <li>• Working Load (DA1-2) 1025kN</li> </ul>	<b>1</b>	DA1-1_BearingCapacity	150
	<b>2</b>	DA1-2_BearingCapacity	120
	<b>3</b>	ReinforcementSteelGrade	500B
	<b>4</b>	SoilVerificationTest	1 no of plate load test
	<b>5</b>	Breadth	1250
	<b>6</b>	Depth	450
	<b>7</b>	Mark	F2
	<b>8</b>	Width	800
	<b>9</b>	BottomDistribution	H10-200
	<b>10</b>	BottomMain	H16-200
	<b>11</b>	SideBar	H10-200
	<b>12</b>	TopDistribution	H10-200
	<b>13</b>	TopMain	H13-200
	<b>14</b>	WorkingLoad_DA1-1	1286
	<b>15</b>	WorkingLoad_DA1-2	1025
	<b>16</b>	MaterialGrade	C32/40

# Grating

## ► By IFC Representation

IFC Entity: <a href="#">IfcDiscreteAccessory</a>						
IFC SubType: GRATING						
S/N	IFC-SG Property	Property Type	Type of Elements	Unit	Input Limitation	Examples
-	-	-	-	-	-	-

## Green Verges

### ► By IFC Representation

IFC Entity: <a href="#">IfcGeographicElement</a>						
IFC SubType: GREENVERGES						
S/N	IFC-SG Property	Property Type	Type of Elements	Unit	Input Limitation	Examples
1	Area	Area	-	m <sup>2</sup>	No	-
2	ApprovedSoilMixture	Boolean	-	-	Yes	TRUE / FALSE
3	Shrubs	Boolean	-	-	Yes	TRUE / FALSE
4	ShrubSpecies	Text	-	-	-	-
5	ApprovedTurfSpecies	Boolean	-	-	Yes	TRUE / FALSE

# Gutter

## ► By IFC Representation

IFC Entity: <b>IfcPipeSegment</b>						
IFC SubType: GUTTER						
S/N	IFC-SG Property	Property Type	Type of Elements	Unit	Input Limitation	Examples
-	-	-	-	-	-	-

IFC Entity: <b>IfcCivilElement</b>						
IFC SubType: GUTTER						
S/N	IFC-SG Property	Property Type	Type of Elements	Unit	Input Limitation	Examples
1	ConstructionMethod	Text	-	-	-	-
2	Height	Length	-	mm	-	-
3	Length	Length	-	mm	-	-
4	Thickness	Length	-	mm	-	-
5	Width	Length	-	mm	-	-
6	Public	Boolean	-	-	Yes	TRUE / FALSE



## Hose Reel

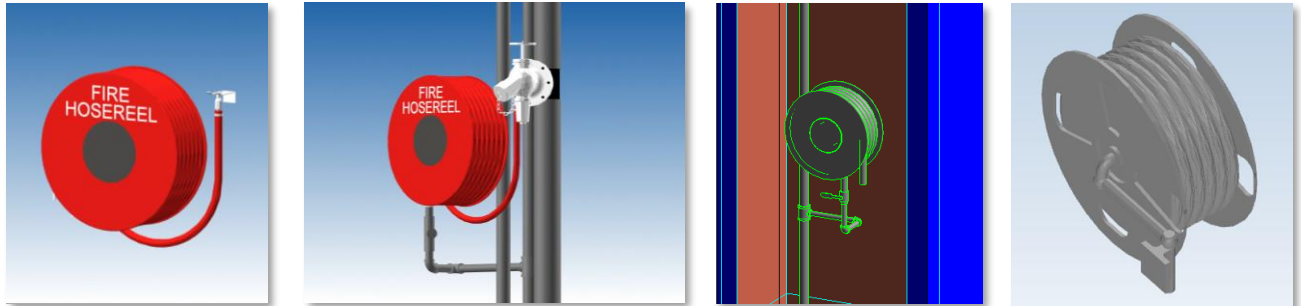

S4 – Fig 42 to 45: Hose Reel

### ► By IFC Representation

<b>IFC Entity:</b> <a href="#">IfcFireSuppressionTerminal</a>						
<b>IFC SubType:</b> HOSEREEL, STANDBYFIREHOSE						
S/N	IFC-SG Property	Property Type	Type of Elements	Unit	Input Limitation	Examples
1	Hose_NominalDiameter	Length	-	mm	No	-

## Household Shelter

### ► Modelling Household Shelters in IFC-SG

- There are 8 types of IFC Entities in a Household Shelter

1) IfcSpace

- a) Internal
- b) External
- c) Setback

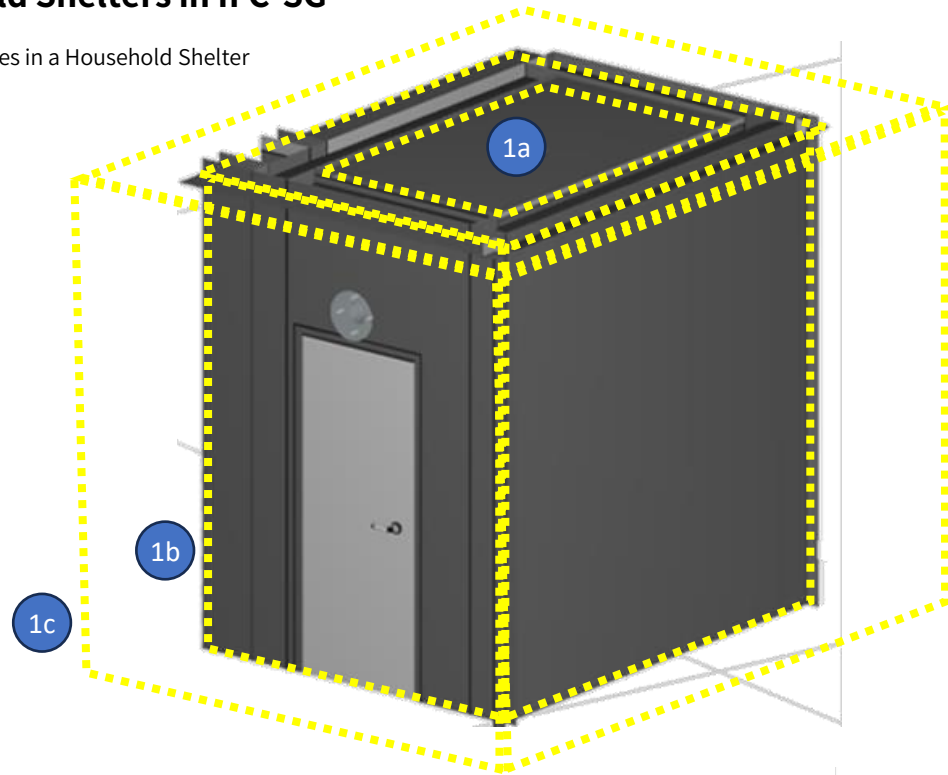

2) IfcSlab

3) IfcWall

4) IfcWindow (Refer to [“Window” component](#))

5) IfcDoor (Refer to [“Door” component](#))

6) IfcLightFixture

7) IfcSwitchingDevice

8) IfcOutlet



Details of the Household Shelter can be shown through 2D supplementary drawings.

# Household Shelter

## ► By IFC Representation

► Parameters below refer to the internal space of the Household Shelter

IFC Entity: <b>lfcSpace</b>						
IFC SubType: SPACE						
S/N	IFC-SG Property	Property Type	Type of Elements	Unit	Input Limitation	Examples
1	SpaceName	Text	-	-	Yes	Household Shelter, Setback
2	Accreditation_PAS	Boolean	-	-	Yes	TRUE/FALSE
3	InternalLength	Length	-	mm	No	-
4	InternalWidth	Length	-	mm	No	-
5	Area	Area	-	m <sup>2</sup>	No	-
6	ConstructionMethod	Text	-	-	-	Precast

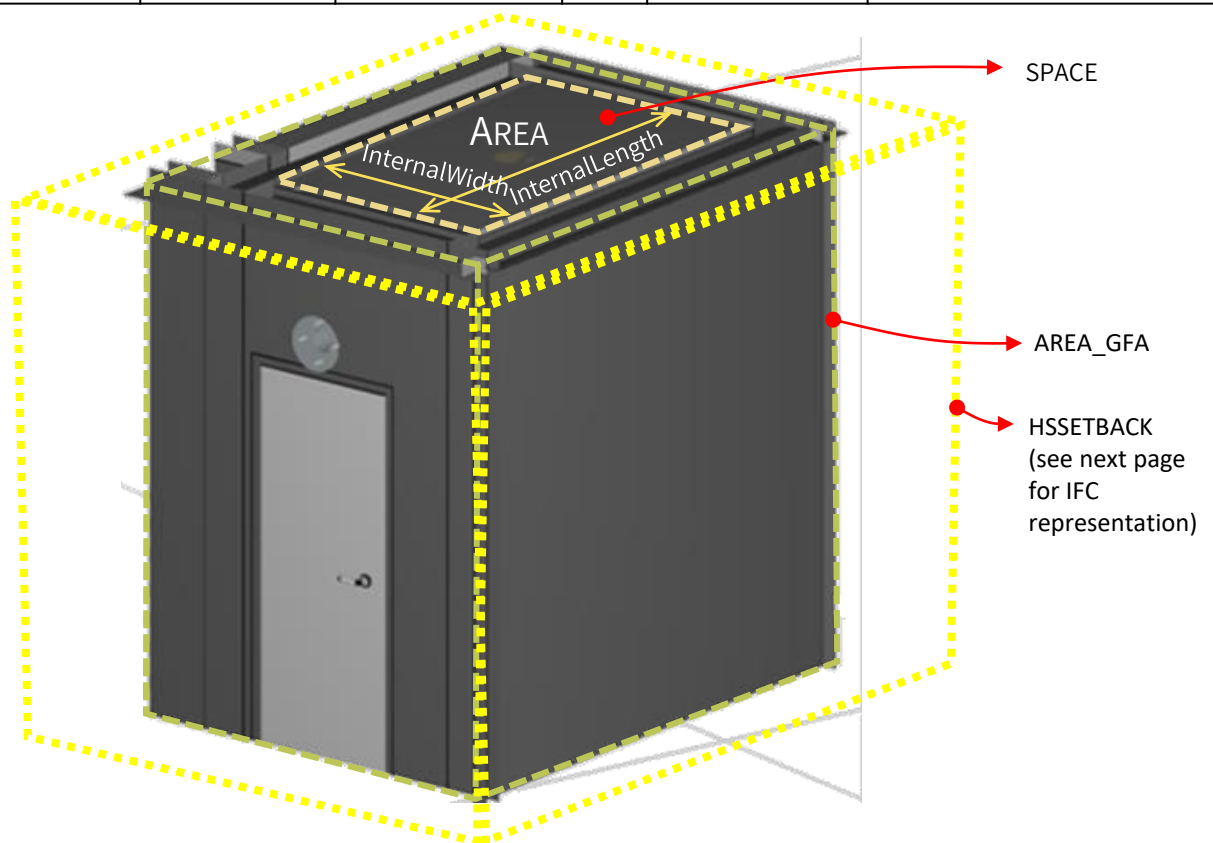

► Parameters below refer to the external “shell” of the Household Shelter

IFC Entity: <b>lfcSpace</b>						
IFC SubType: AREA_GFA						
S/N	IFC-SG Property	Property Type	Type of Elements	Unit	Input Limitation	Examples
1	AGF_Name	Text	-	-	Yes	Household Shelter

## Household Shelter

### ► By IFC Representation (continued from previous page)

➤ Parameters below refer to the internal space and the setback of the Household Shelter

<b>IFC Entity:</b> <a href="#">IfcSpace</a>						
<b>IFC SubType:</b> HSSETBACK						
S/N	IFC-SG Property	Property Type	Type of Elements	Unit	Input Limitation	Examples
-	-	-	-	-	-	-

➤ ST requirements for Wall and Slab components should be added in addition to the household shelter ST requirements below.

<b>IFC Entity:</b> <a href="#">IfcWall</a> , <a href="#">IfcSlab</a>						
<b>IFC SubType:</b> N.A.						
S/N	IFC-SG Property	Property Type	Type of Elements	Unit	Input Limitation	Examples
1	ConstructionMethod	Text	-	-	Yes	Refer to list <sup>^</sup>
2	Accreditation_PAS	Boolean	-	-	Yes	TRUE / FALSE
3	Thickness	Length	-	mm	No*	300
4	ShelterUsage	Boolean	-	-	Yes	TRUE / FALSE

<b>IFC Entity:</b> <a href="#">IfcLightFixture</a>						
<b>IFC SubType:</b> N.A.						
S/N	IFC-SG Property	Property Type	Type of Elements	Unit	Input Limitation	Examples
-	-	-	-	-	-	-

<b>IFC Entity:</b> <a href="#">IfcOutlet</a>						
<b>IFC SubType:</b> COMMUNICATIONOUTLET, DATAOUTLET, POWEROUTLET						
S/N	IFC-SG Property	Property Type	Type of Elements	Unit	Input Limitation	Examples
-	-	-	-	-	-	-

<b>IFC Entity:</b> <a href="#">IfcSwitchingDevice</a>						
<b>IFC SubType:</b> N.A.						
S/N	IFC-SG Property	Property Type	Type of Elements	Unit	Input Limitation	Examples
-	-	-	-	-	-	-

# Interceptor

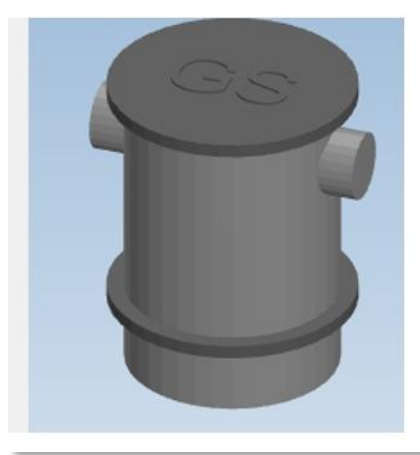

S4 – Fig 46 : Interceptor (Grease)

## ► By IFC Representation

IFC Entity: <b>IfcInterceptor</b>						
IFC SubType: GREASE, OIL						
S/N	IFC-SG Property	Property Type	Type of Elements	Unit	Input Limitation	Examples
1	ComplyToPUBStandardDrawing	Boolean	-	-	Yes	TRUE / FALSE
2	ReferToDrawingNumber	Text	-	-	No	-
3	InvertLevel	Text	-	-	No	-
4	TopLevel	Text	-	-	No	-
5	Diameter	Length	-	mm	No	-
6	Height	Length	-	mm	No	-
7	Length	Length	-	mm	No	-
8	Width	Length	-	mm	No	-
9	TradeEffluent	Boolean	-	-	Yes	TRUE / FALSE

# Lamp Post

## ► By IFC Representation

<b>IFC Entity:</b> <a href="#">IfcCivilElement</a>						
<b>IFC SubType:</b> LAMPPOST						
S/N	IFC-SG Property	Property Type	Type of Elements	Unit	Input Limitation	Examples
-	-	-	-	-	-	-

### Notes

- Only lamp post within the site boundary will need to be modelled, using placeholder objects. It is not necessary to replicate details of actual lamp posts.

# Landscape Plants

## ► Modelling Landscape Plants in IFC-SG

- As long as relevant IFC-SG requirements are embedded in the tree object, trees may be modelled as simplified lollipop BIM components. We are mindful that more elaborate tree models can increase the file size of the BIM model.

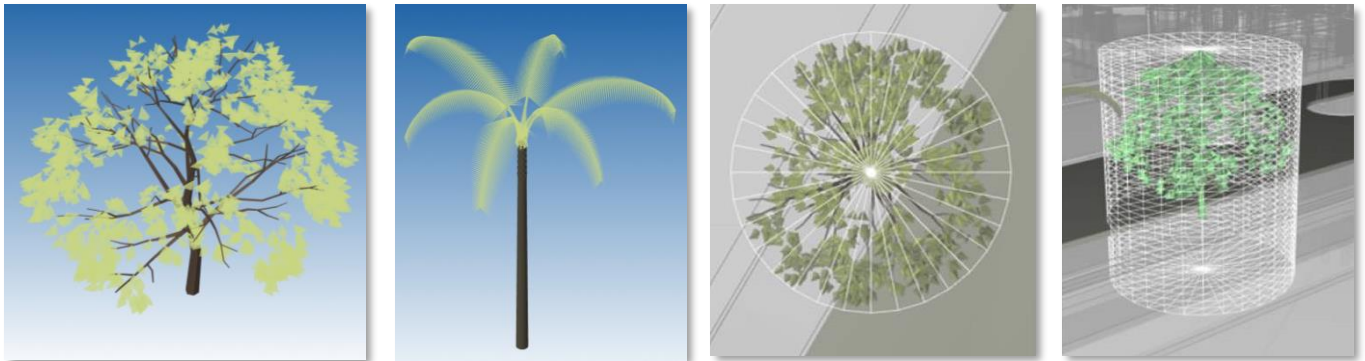

S4 – Fig 47 to 50: Trees

## ► By IFC Representation

IFC Entity: <b>lfcGeographicElement</b>						
IFC SubType: LANDSCAPE_TREE, LANDSCAPE_PALM, LANDSCAPE_SHRUBS						
S/N	IFC-SG Property	Property Type	Type of Elements	Unit	Input Limitation	Examples
1	ReasonForRemoval	Text	-	-	-	-
2	Species	Text	-	-	-	Samanea saman, Cyrtostachys renda, Gardenia tubifera
3	Status	Text	-	-	-	Proposed, To be conserved, To be retained, To be cut
4	TreeNumber	Text	-	-	-	1, 2, 3
5	Girth	Length	-	m	-	0.1, 0.3, 1.0
6	Height	Length	-	m	-	2.5, 10.0
7	SingleStem	Boolean	-	-	Yes	TRUE / FALSE
8	TreeSize	Text	-	-	-	Palm, Small to medium, Large
9	Turf	Boolean	-	-	Yes	TRUE / FALSE
10	Roadside	Boolean	-	-	Yes	TRUE / FALSE

IFC Entity: <b>lfcGeographicElement</b>						
IFC SubType: LANDSCAPE_EXTERNALPLANTING						
S/N	IFC-SG Property	Property Type	Type of Elements	Unit	Input Limitation	Examples
1	ApprovedSoilMixture	Boolean	-	-	Yes	TRUE / FALSE

# Lift

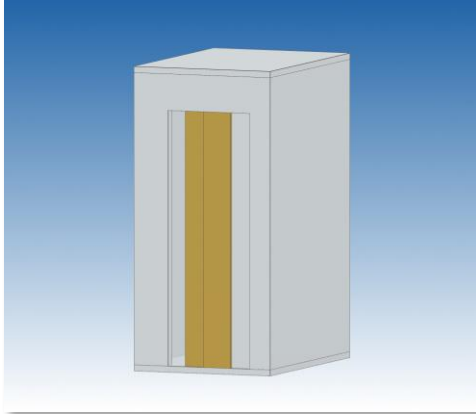

S4 – Fig 51 : Lift

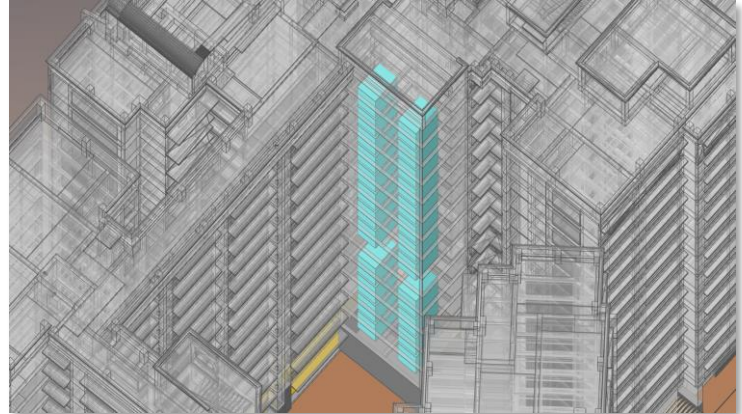

S4 – Fig 52 : Lift Stack in relation to Building

## ► By IFC Representation

IFC Entity: <b>lfcTransportElement</b>						
IFC SubType: LIFT, CARLIFT						
S/N	IFC-SG Property	Property Type	Type of Elements	Unit	Input Limitation	Examples
1	BarrierFreeAccessibility	Boolean	-	-	Yes	TRUE / FALSE
2	Length	Length	-	mm	No	-
3	Width	Length	-	mm	No	-
4	ClearDepth	Length	-	mm	No	-
5	ClearHeight	Length	-	mm	No	-
6	ClearWidth	Length	-	mm	No	-
7	FireFightingLift	Boolean	-	-	Yes	TRUE / FALSE
8	LiftType	Text	-	-	No	Goods Lift, Platform Lift, Bin Lifter



# Parking Lot

## ► Modelling Parking Lots in IFC-SG

- To be modelled concurrently with reference to Road and Ramp components
- Electric Vehicle (EVs) Parking Lots are not specifically modelled out. Instead, they are indicated by modelling the EV Charger at each lot.

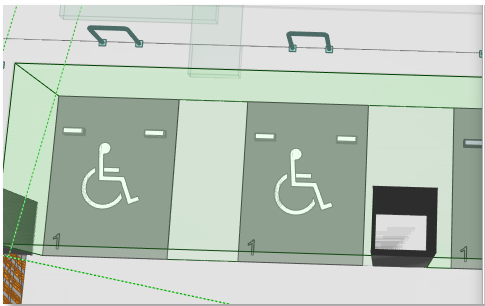

S4 – Fig 53 : Accessible Parking Lots

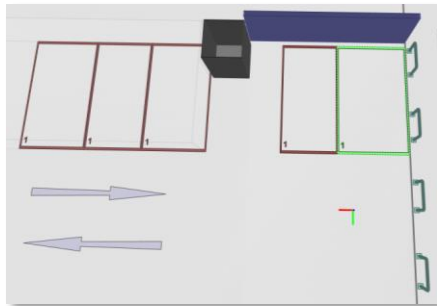

S4 – Fig 54 : Vehicular Parking Lots

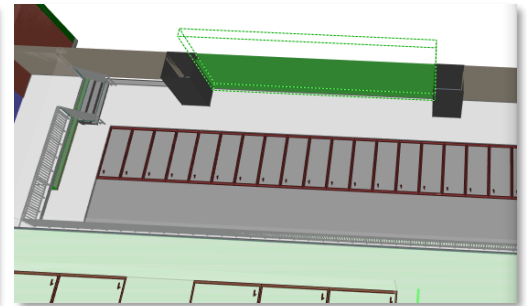

S4 – Fig 55 : Vehicular Parking Lots

3 Examples of Bicycle Racks		
Single-Tier Wheel Rack	Single-Tier U-Bar	Double-Tier
<p>Source: <a href="#">LTA</a></p>	<p>Source: <a href="#">LTA</a></p>	<p>Source: <a href="#">LTA</a></p>
<p>Width : 650 mm                      Length : 1800 mm                      BicycleLotCount : 1                      BicycleRack_Type : Single-Tier Wheel Rack</p>	<p>Width : 650 mm                      Length : 1800 mm                      BicycleLotCount : 2                      BicycleRack_Type : Single-Tier U-Bar</p>	<p>Width : 650 mm                      Length : 1975 mm                      BicycleLotCount : 2                      BicycleRack_Type : Double-Tier</p>

# Parking Lot

## ► By IFC Representation

IFC Entity: <b>IfcBuildingElementProxy</b>						
IFC SubType: CARLOT, MOTORCYCLELOT, LORRYLOT, COACHLOT, ARTICULATEDVEHICLELOT						
S/N	IFC-SG Property	Property Type	Type of Elements	Unit	Input Limitation	Examples
1	BarrierFreeAccessibility	Boolean	-	-	Yes	TRUE / FALSE
2	FamilyLot	Boolean	-	-	Yes	TRUE / FALSE
3	Length	Length	-	mm	No	N.A.
4	Width	Length	-	mm	No	N.A.
5	LotNumber	Text	-	-	No	123
6	CarParking_ServedByCarLift	Boolean	-	-	Yes	TRUE / FALSE
7	MechanisedParkingSystem	Boolean	-	-	Yes	TRUE / FALSE
8	ParkingUse	Text	-	-	No	Electric Vehicle, Oil Tanker, Buggy, Vacuum Truck, Mobile Tanker
9	Perforated	Boolean	-	-	Yes	TRUE / FALSE
10	OpenAtGrade	Boolean	-	-	Yes	TRUE / FALSE
11	VehicleType	Text	-	N.A.	No	Rigid-framed vehicle

IFC Entity: <b>IfcBuildingElementProxy</b>						
IFC SubType: BICYCLELOT						
S/N	IFC-SG Property	Property Type	Type of Elements	Unit	Input Limitation	Examples
1	Width	Length	-	mm	No	650mm
2	Length	Length	-	mm	No	1800mm, 1975mm
3	BicycleLotCount	Integer	-	-	No	Limited to 1 or 2 only
4	BicycleRack_Type	Text	-	-	No	Single-Tier Wheel Rack, Single-Tier U-Bar, Double-Tier

## Parking Lot

### ► By IFC Representation (continued from previous page)

IFC Entity: <b>IfcSpace</b>						
IFC SubType: N.A.						
S/N	IFC-SG Property	Property Type	Type of Elements	Unit	Input Limitation	Examples
1	VentilationMode	Text	-	-	Yes	Natural Ventilation, Air Conditioning Mechanical Ventilation, Mechanical Ventilation
2	Area	Length	-	m <sup>2</sup>	No	-

IFC Entity: <b>IfcSpace</b>						
IFC SubType: AREA_GFA						
S/N	IFC-SG Property	Property Type	Type of Elements	Unit	Input Limitation	Examples
1	AGF_Name	Text	-	-	No	Car Parking Lot

IFC Entity: <b>IfcTransportElement</b>						
IFC SubType: CARLIFT						
S/N	IFC-SG Property	Property Type	Type of Elements	Unit	Input Limitation	Examples
1	Width	Length	-	mm	No	600mm, 650mm
2	Length	Length	-	mm	No	1800mm, 2000mm

IFC Entity: <b>IfcBuildingElementProxy</b>						
IFC SubType: CARLOBBY, HOLDINGBAY, QUEUINGSPACE						
S/N	IFC-SG Property	Property Type	Type of Elements	Unit	Input Limitation	Examples
1	Width	Length	-	mm	No	-
2	Length	Length	-	mm	No	-

# Pile

## ► Modelling Pile in IFC-SG

- All the pile elements shall be modelled as per true coordinates in the IFC-SG model with the necessary information required as stipulated in the tables below.
  - Piles with same foundation design are allowed to have same pile marks and design information. All the pile marks and design information have to be embedded in every pile element.
- The following pile-related parameters do not need to be provided for individual piles. Instead, they are to be provided in general.
  - Pile Model Factor, Shaft R4 Design Factor, End Bearing R4 Design Factor
  - Number of ULT Tests, Number of Working Load Tests – Maintained Load Tests and Rapid Load Tests, Number of Non Destructive Test Piles
- Piles with same foundation design are allowed to have same pile marks and design information. All the pile marks and design information have to be embedded in every pile element.

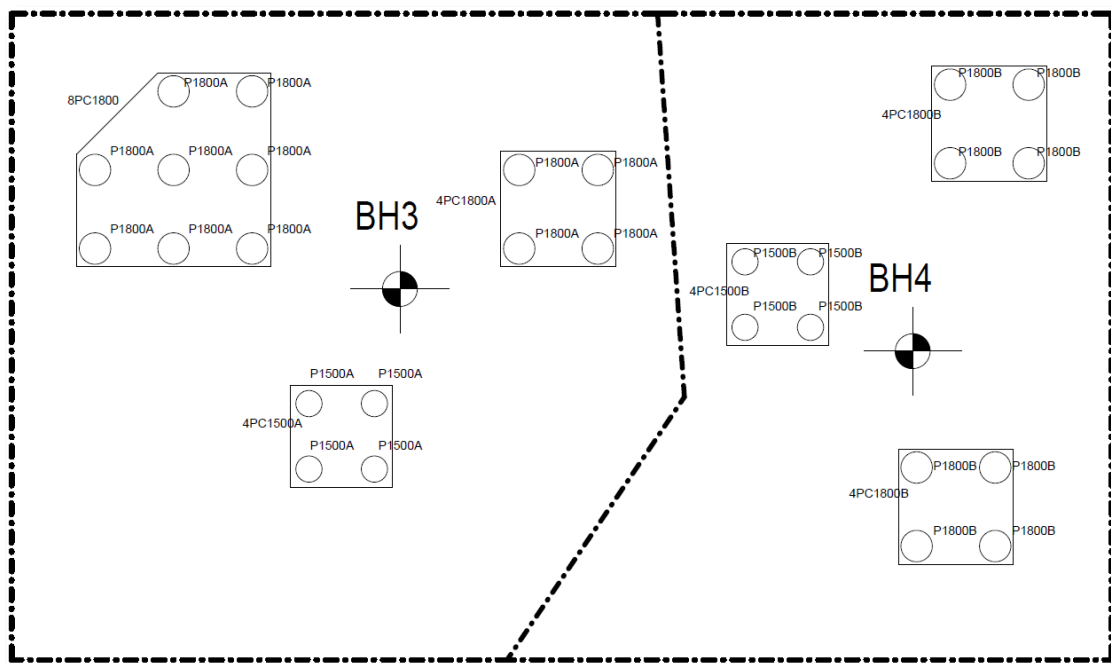

S4 – Fig 58 : Pile Grouping

Mark	Diameter	BoreholeRef	MaterialGrade	Reinforcement SteelGrade	Construction Method	PileType	Length	CutOffLevel_SHD	SHDLevel_SPT MoreThan_100N	MainRebar	Stirrups
P1500A	1500	BH3	C32/40	500B	CIS	Bored	35450	-2.75	6.5	12H25	H10-300
P1500B	1500	BH4	C32/40	500B	CIS	Bored	43650	-2.75	7.6	12H25	H10-300
P1800A	1800	BH3	C32/40	500B	CIS	Bored	38650	-2.75	5.5	18H20	H10-300
P1800B	1800	BH4	C32/40	500B	CIS	Bored	42450	-2.75	7.1	18H20	H10-300

Mark	Reinforcement Length	NegativeSkin Friction	DA1-1_Compression DesignLoad	DA1-2_Compression DesignLoad	DA1-1_Compression Capacity	DA1-2_Compression Capacity	StructuralCompression Capacity	No of piles
P1500A	24	437	6593	6124	6897	6537	7250	4
P1500B	24	635	6872	6539	7153	6872	7250	4
P1800A	24	513	8326	7934	8652	8257	8932	12
P1800B	24	670	8436	7964	8594	8136	8932	8

# Pile

## ► By IFC Representation

- Individual Pile

IFC Entity: <b>IfcPile</b>						
IFC SubType: N.A.						
S/N	IFC-SG Property	Property Type	Type of Elements	Unit	Input Limitation	Examples
1	MaterialGrade	Text	All piles	-	Yes	Refer to list <sup>^</sup>
2	BoreholeRef	Text	All piles	-	No	BH2, BH3, BH12-2
3	ConstructionMethod	Text	All piles	-	Yes	Refer to list <sup>^</sup>
4	DA1-1_CompressionCapacity	Integer	All piles	kN	No	5683
5	DA1-1_TensionCapacity	Integer	When required / relevant	kN	No	3655
6	DA1-2_CompressionCapacity	Integer	All piles	kN	No	4823
7	DA1-2_TensionCapacity	Integer	When required / relevant	kN	No	3025
8	MinEmbedmentIntoBearingLayer_SPT_MoreThan_100N	Real	When required / relevant	m	No	16.5
9	MinEmbedmentIntoBearingLayer_SPT_MoreThan_60N	Real	When required / relevant	m	No	23.2
10	MinRockSocketingLength	Real	When required / relevant	m	No	16.5
11	ReinforcementSteelGrade	Text	RC piles <sup>#</sup>	N/mm2	Yes	500B
12	StructuralCompressionCapacity	Integer	All piles	kN	No	6525
13	StructuralTensionCapacity	Integer	When required / relevant	kN	No	3825
14	Breadth	Length	RC non-circular piles	mm	No*	300
15	CutOffLevel_SHD	Real	All piles	SHD Level	No	-1.35
16	Diameter	Length	RC circular piles	mm	No*	600
17	Length	Length	All piles	mm	No*	40500
18	Mark	Text	All piles	-	No	P156
19	MemberSection	Text	Steel piles	-	No	CHS500x3.0, 254x254x63 kg/m
20	ToeLevel_SHD	Real	All piles	SHD Level	No	-63.35
21	Width	Length	RC non-circular piles	mm	No*	600
22	MainRebar	Text	RC piles <sup>#</sup>	-	Yes	10H32+10H16
23	PileType	Text	RC piles <sup>#</sup>	-	Yes	Refer to list <sup>^</sup>
24	ReinforcementLength	Text	RC piles <sup>#</sup>	m	Yes	Refer to list <sup>^</sup>
25	Stirrups	Text	RC piles <sup>#</sup>	-	Yes	H16-250

\* Parameter is populated from the dimensions of BIM elements modelled.

<sup>^</sup> List can be found [here](#).

<sup>#</sup> RC piles denotes to RC precast pile, cast-in situ bored pile or spun pile

# Pile

## ► By IFC Representation (continued from previous page)

IFC Entity: <b>IfcPile</b>						
IFC SubType: N.A.						
S/N	IFC-SG Property	Property Type	Type of Elements	Unit	Input Limitation	Examples
25	Stirrups	Text	RC piles <sup>#</sup>	-	Yes	H16-250
26	DA1-1_CompressionDesignLoad	Integer	All piles	kN	No	5515
27	DA1-1_TensionDesignLoad	Integer	When required / relevant	kN	No	3255
28	DA1-2_CompressionDesignLoad	Integer	All piles	kN	No	4650
29	DA1-2_TensionDesignLoad	Integer	When required / relevant	kN	No	2850
30	NegativeSkinFriction	Integer	When required / relevant	kN	No	135

► Parameters below can be added as project information for piles in general. It is not necessary to input them in individual piles

IFC Entity: <b>IfcBuilding</b>						
IFC SubType: N.A.						
S/N	IFC-SG Property	Property Type	Type of Elements	Unit	Input Limitation	Examples
1	PileModelFactor	Real	when required / relevant	-	No	1.35 / 1.55
2	ShaftR4DesignFactor	Real	when required / relevant	-	No	
3	EndBearingR4DesignFactor	Real	when required / relevant	-	No	
4	NoOfULTTest	Integer	when required / relevant	-	No	2
5	NoOfWorkingLoadTest_MaintainedLoadTest	Integer	when required / relevant	-	No	3
6	NoOfWorkingLoadTest_RapidLoadTest	Integer	when required / relevant	-	No	3
7	NoOfNonDestructiveTestPile	Integer	when required / relevant	-	No	8

\* Parameter is populated from the dimensions of BIM elements modelled.

^ List can be found [here](#).

# RC piles denotes to RC precast pile, cast-in situ bored pile or spun pile

# Pile

## ► Example of Pile (RC Bored Pile) Structural Element Input

1600mm Diameter Bored Piles	IFC Entity: <b>IfcPile</b>			
	IFC SubType: N.A.			
<ul style="list-style-type: none"> <li>• Pile mark – P-1600</li> <li>• Borehole - BH3</li> <li>• Concrete grade C35/45</li> <li>• Pile length 35.45m</li> <li>• Main rebar 8H16</li> <li>• 24m length reinforcement cage</li> <li>• Embedded to SPT100 for 6.5m</li> <li>• Not subject to negative skin friction and tension load</li> </ul>	S/N	IFC-SG Property	Examples	
		1	ReinforcementSteelGrade	500B
		2	MaterialGrade	C35/45
		3	BoreholeRef	BH3
		4	ConstructionMethod	CIS
		5	DA1-1_CompressionCapacity	5683
		6	DA1-2_CompressionCapacity	4823
		7	MinEmbedmentIntoBearingLayer_SPT_MoreThan_100N	6.5
		8	StructuralCompressionCapacity	6525
		9	CutOffLevel_SHD	-1.55
		10	Diameter	1600
		11	Length	35450
		12	Mark	P-1600
		13	ToeLevel_SHD	-37
		14	MainRebar	8H16
		15	PileType	Bored
		16	ReinforcementLength	24
		17	Stirrups	H10-300
		18	DA1-1_CompressionDesignLoad	5515
	19	DA1-2_CompressionDesignLoad	4650	

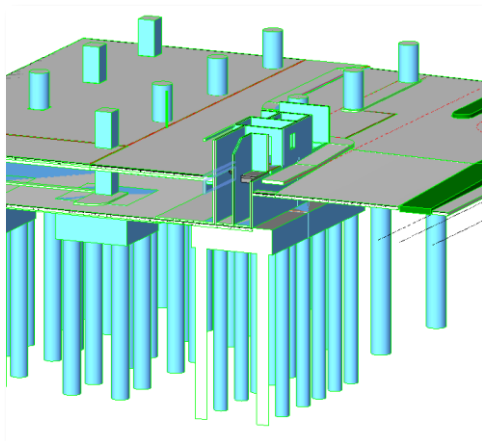

S4 – Fig 56 : Pile

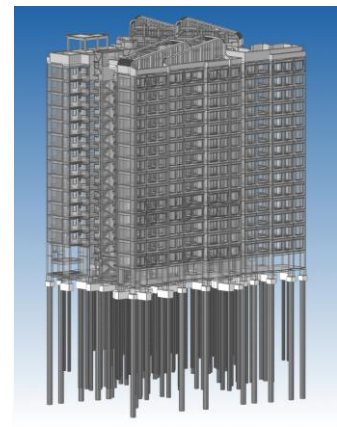

S4 – Fig 57 : Pile in relation to Building

# Pile

## ► Example of Pile (RC Jacked In Pile) Structural Element Input

250mm x 250mm Jacked In Piles		IFC Entity: <b>lfcPile</b>	
		IFC SubType: N.A.	
<ul style="list-style-type: none"> <li>• Pile mark – 250x250</li> <li>• Borehole – BH1</li> <li>• Concrete grade C35/45</li> <li>• Pile length 18m</li> <li>• Main rebar 4H13</li> <li>• 12m length reinforcement cage</li> <li>• Embedded to SPT60 for 3.3m</li> <li>• Not subject to negative skin friction and tension load</li> </ul>	S/N	IFC-SG Property	Examples
	1	ReinforcementSteelGrade	500B
	2	MaterialGrade	C35/45
	3	BoreholeRef	BH1
	4	ConstructionMethod	PC
	5	DA1-1_CompressionCapacity	1315
	6	DA1-2_CompressionCapacity	1153
	7	MinEmbedmentIntoBearingLayer_SPT_MoreThan_60N	3.3
	8	StructuralCompressionCapacity	2085
	9	Breadth	250
	10	CutOffLevel_SHD	-0.8
	11	Length	18000
	12	Mark	250x250
	13	ToeLevel_SHD	-18.8
	14	Width	250
	15	MainRebar	4H13
	16	PileType	Jacked in
	17	ReinforcementLength	12
	18	Stirrups	H10-300
	19	DA1-1_CompressionDesignLoad	1207
20	DA1-2_CompressionDesignLoad	1058	



## Pipes / Drains

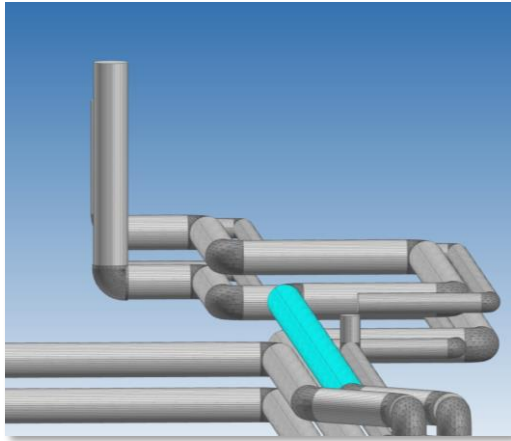

S4 – Fig 59 : Pipes

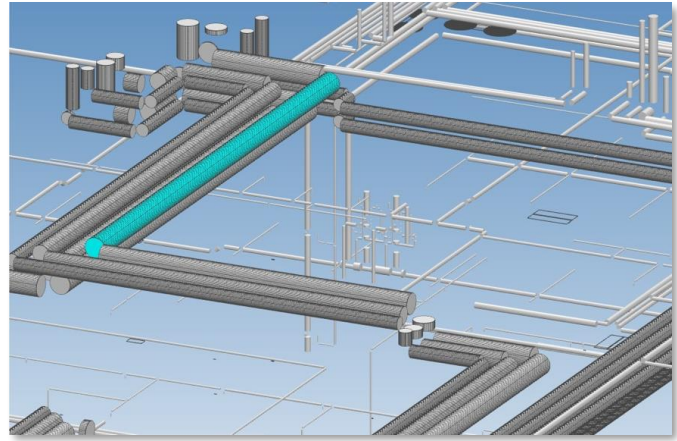

S4 – Fig 60 : Pipes

### ► By IFC Representation

IFC Entity: <b>IfcPipeSegment</b>						
IFC SubType: RIGIDSEGMENT, FLEXIBLESEGMENT						
S/N	IFC-SG Property	Property Type	Type of Elements	Unit	Input Limitation	Examples
1	PreInsulated	Boolean	-	-	Yes	TRUE / FALSE
2	ConstructionMethod	Text	-	-	-	-
3	Perforated	Boolean	-	-	Yes	TRUE / FALSE
4	InnerDiameter	Length	-	mm	No	-
5	Material	Text	-	-	-	-
6	Gradient	Text	-	-	-	-
7	Length	Length	-	mm	No	-
8	Thickness	Length	-	mm	No	-
9	TradeEffluent	Boolean	-	-	Yes	TRUE / FALSE
10	DemountableStructureAbovePipe	Boolean	-	-	Yes	TRUE / FALSE

IFC Entity: <b>IfcDuctSegment, IfcDuctFitting</b>						
IFC SubType: N.A.						
S/N	IFC-SG Property	Property Type	Type of Elements	Unit	Input Limitation	Examples
1	PreInsulated	Boolean	-	-	Yes	TRUE / FALSE
2	ConstructionMethod	Text	-	-	-	-
3	TradeEffluent	Boolean	-	-	Yes	TRUE / FALSE

## Pipes / Drains

### ► By IFC Representation (continued from previous page)

<b>IFC Entity:</b> <a href="#">IfcPipeSegment</a>						
<b>IFC SubType:</b> SCUPPERDRAIN, SPOOL, FLARESTACK, RAINWATEROUTLET						
S/N	IFC-SG Property	Property Type	Type of Elements	Unit	Input Limitation	Examples
1	-	-	-	-	-	-

<b>IFC Entity:</b> <a href="#">IfcPipeFitting</a>						
<b>IFC SubType:</b> BEND, DRAINCHANNELBEND, ENTRY, EXIT, FLANGEADAPTOR, FLEXIBLECOUPLING, JUNCTION, OBSTRUCTION, PIPESILENCER, SHORTPIECE						
S/N	IFC-SG Property	Property Type	Type of Elements	Unit	Input Limitation	Examples
1	InnerDiameter	Length	-	mm	No	-
2	NominalDiameter	Length	-	mm	No	-
3	OuterDiameter	Length	-	mm	No	-
4	Thickness	Length	-	mm	No	-

#### Notes

- Sanitary drain-lines are to be submitted as schematic and/or 2D drawings. If industry would like to submit in 3D, it is optional and will also be accepted.
- Under the Covering component, Pipe Sleeves should be indicated where relevant

## Planter Box / Planting Trough

### ► By IFC Representation

<b>IFC Entity:</b> <a href="#">IfcFurniture</a>						
<b>IFC SubType:</b> PLANTERBOX						
S/N	IFC-SG Property	Property Type	Type of Elements	Unit	Input Limitation	Examples
-	-	-	-	-	-	-

<b>IFC Entity:</b> <a href="#">IfcBuildingElementProxy</a>						
<b>IFC SubType:</b> LANDSCAPE_PLANTINGTROUGH						
S/N	IFC-SG Property	Property Type	Type of Elements	Unit	Input Limitation	Examples
-	-	-	-	-	-	-

## Planting Areas

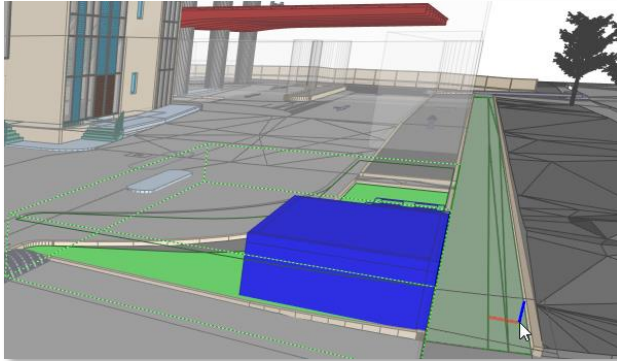

S4 – Fig 61 : Planting Areas highlighted in Green

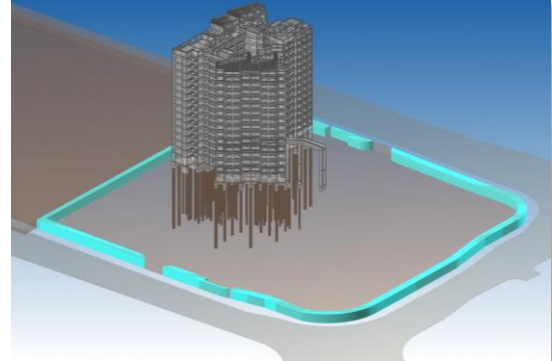

S4 – Fig 62 : Planting Areas

### ► By IFC Representation

IFC Entity: <b>lfcGeographicElement</b>						
IFC SubType: PLANTING AREAS						
S/N	IFC-SG Property	Property Type	Type of Elements	Unit	Input Limitation	Examples
1	Area	Area	-	m <sup>2</sup>	No	-
2	ApprovedSoilMixture	Boolean	-	-	Yes	TRUE / FALSE
3	Status	Text	-	-	Yes	Existing, Proposed / New, To be Removed
4	Turf	Boolean	-	-	Yes	TRUE / FALSE
5	TurfSpecies	Text	-	-	No	-
6	Compensated	Boolean	-	-	Yes	TRUE / FALSE
7	CarparkProvision	Boolean	-	-	Yes	TRUE / FALSE

#### Notes

- QPs are to separately submit calculation for compensated green buffer area.

## Pollution Control

### ► Modelling Pollution Control Emissions

- Only substances and items that are analysed by the relevant equipment or device will be required in the IFC-SG properties. For example, if Chlorine is analysed, an IFC-SG value will need to be added for the Chlorine IFC-SG Property. If Chlorine is not analysed, it is not necessary to add the property.

### ► By IFC Representation

IFC Entity: <b>ifcBuildingElementProxy</b>						
IFC SubType: AIRIMPURITIESENSOR, FUELBURNINGEQUIPMENT, INCINERATOR, POLLUTIONCONTROLEQUIPMENT						
S/N	IFC-SG Property	Property Type	Type of Elements	Unit	Input Limitation	Examples
1 - 58	Refer to Air Impurities (AI_) and Trade Effluent Discharge (TED_ List below	Text	-	-	No	76 mg/Nm3, 0.1, 150

### ► IFC-SG Properties

S/N	IFC-SG Property	S/N	IFC-SG Property	S/N	IFC-SG Property
1	AI_AmmoniaAndAmmonium	21	AI_SulphurTrioxideAndAcidGases	41	TED_Magnesium
2	AI_Antimony	22	AI_SulphurTrioxideOrSulphuricAcidMist	42	TED_Manganese
3	AI_Arsenic	23	AI_VinylChlorideMonomer	43	TED_Mercury
4	AI_Benzene	24	TED_Arsenic	44	TED_MetalsInTotal
5	AI_Cadmium	25	TED_Barium	45	TED_Nickel
6	AI_CarbonMonoxide	26	TED_Beryllium	46	TED_Nitrate
7	AI_Chlorine	27	TED_BiochemicalOxygenDemand	47	TED_PHValue
8	AI_Copper	28	TED_Boron	48	TED_PhenolicCompound
9	AI-DioxinsAndFurans	29	TED_Cadmium	49	TED_Phosphate
10	AI_EthyleneOxide	30	TED_Calcium	50	TED_Selenium
11	AI_FlourineAndHydrofluoricAcide	31	TED_ChemicalOxygenDemand	51	TED_Silver
12	AI_Formaldehyde	32	TED_Chloride	52	TED_Sulphate
13	AI_HydrogenChloride	33	TED_Chromium	53	TED_Sulphide
14	AI_HydrogenSulphide	34	TED_Colour	54	TED_TemperatureOfDischarge
15	AI_Lead	35	TED_Copper	55	TED_Tin
16	AI_Mercury	36	TED_Cyanide	56	TED_TotalDissolvedSolid
17	AI_OxidesOfNitrogen	37	TED_Detergent	57	TED_TotalSuspendedSolid
18	AI_ParticulateSubstances	38	TED_GreaseAndOil	58	TED_Zinc
19	AI_StyreneMonomer	39	TED_Iron		
20	AI_SulphurDioxide	40	TED_Lead		

## Prefabricated Building Systems and MEP Components

### ► By IFC Representation

IFC Entity: <b>lfcSpace</b>						
IFC SubType: PREFABRICATEDBATHROOMUNIT, PREFABRICATEDDANDPREFINISHEDWALL, PREFABRICATEDDANDPREFINISHEDFLOOR, PREFABRICATEDDANDPREFINISHEDCEILING, PRECASTEXTERNALWALLWITHCAST-INWINDOWS, PREFABRICATEDPUMPSKID, PREFABRICATEDMEPVERTICALMODULE, PREFABRICATEDMEPPLANTMODULE, PREFABRICATEDMEPHORIZONTALMODULE						
S/N	IFC-SG Property	Property Type	Type of Elements	Unit	Input Limitation	Examples
1	SpaceName	Text	-	-	No	Master Bath, Maid Bath, Yard Bath
2	InternalLength	Length	-	mm	No	-
3	InternalWidth	Length	-	mm	No	-
4	ConstructionMethod	Text	-	-	No	Prefab & Prefinished, Precast
5	Accreditation_PAS	Boolean	-	-	Yes	TRUE / FALSE
6	MechanicalConnectionType	Text	-	-	Yes	-

IFC Entity: <b>lfcPipeFitting, lfcPipeSegment, lfcDuctFitting, lfcDuctSegment</b>						
IFC SubType: RIGIDSEGMENT, FLEXIBLESEGMENT						
S/N	IFC-SG Property	Property Type	Type of Elements	Unit	Input Limitation	Examples
1	PreInsulated	Boolean	-	-	Yes	TRUE / FALSE
2	ConstructionMethod	Text	-	-	Yes	Prefabricated

IFC Entity: <b>lfcDiscreteAccessory</b>						
IFC SubType: PIPESUPPORT						
S/N	IFC-SG Property	Property Type	Type of Elements	Unit	Input Limitation	Examples
1	IsCommon	Boolean	-	-	Yes	TRUE / FALSE

IFC Entity: <b>lfcDistributionSystem</b>						
IFC SubType: CHILLEDWATER						
S/N	IFC-SG Property	Property Type	Type of Elements	Unit	Input Limitation	Examples
1	PreInsulated	Boolean	-	-	Yes	TRUE / FALSE
2	ConstructionMethod	Text	-	-	Yes	Prefabricated

#### Notes

- lfcSpace components refer to APCS and Prefabricated MEP Systems
- Other components refer to Prefabricated MEP Components

## Project Development Type

### ► By IFC Representation

IFC Entity: <a href="#">IfcBuilding</a>						
IFC SubType: N.A.						
S/N	IFC-SG Property	Property Type	Type of Elements	Unit	Input Limitation	Examples
1	OwnerBuiltOwnerStay	Boolean	-	-	Yes	TRUE / FALSE
2	ProjectDevelopmentType	Text	-	-	No	Residential (landed), Residential (non-landed), Mixed Development, Commercial, Industrial, Healthcare, Institutional, Agriculture, Transport Stations, Civil engineering works / Infrastructure, Free-standing structures, Others

#### Notes

- Only one Project Development Type property applies to the entire IFC model

# Pump

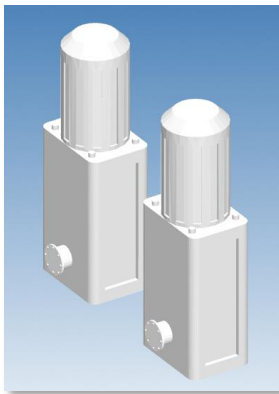
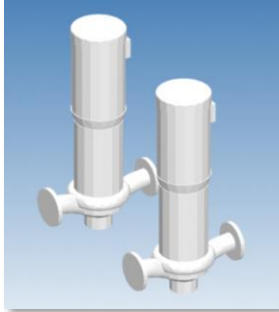

S4 – Fig 63 : Pump

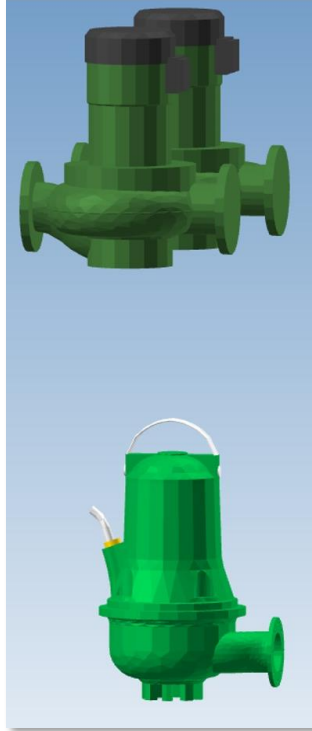

S4 – Fig 64 : Pump

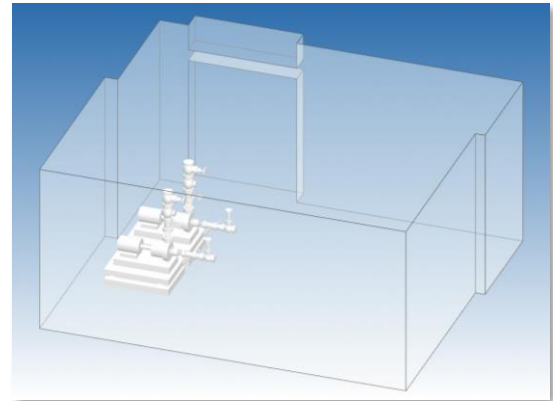

S4 – Fig 65 : Pump

## ► By IFC Representation

IFC Entity: <b>lfcPump</b>						
IFC SubType: SUMPPUMP						
S/N	IFC-SG Property	Property Type	Type of Elements	Unit	Input Limitation	Examples
1	Capacity	VolumetricFlowRate	-	L/s or m3/s	-	1L/s or 1m3/s
2	Duty	Boolean	-	N.A.	Yes	TRUE / FALSE
3	Standby	Boolean	-	N.A.	Yes	TRUE / FALSE
4	PumpHead	Length	-	m	No	1, 2



## Racking System

### ► By IFC Representation

<b>IFC Entity:</b> <a href="#">IfcFurniture</a>						
<b>IFC SubType:</b> RACK						
S/N	IFC-SG Property	Property Type	Type of Elements	Unit	Input Limitation	Examples
-	-	-	-	-	-	-

# Railing

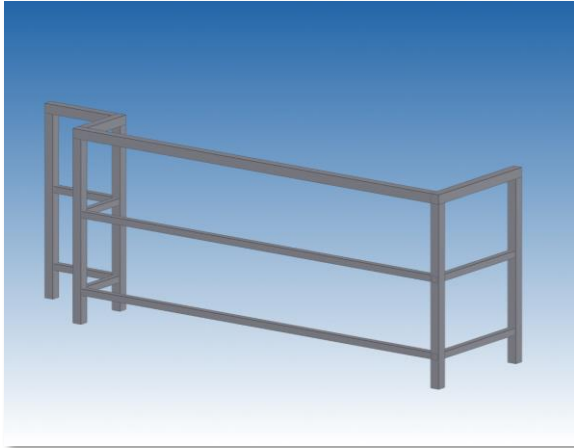

S4 – Fig 66 : Railing

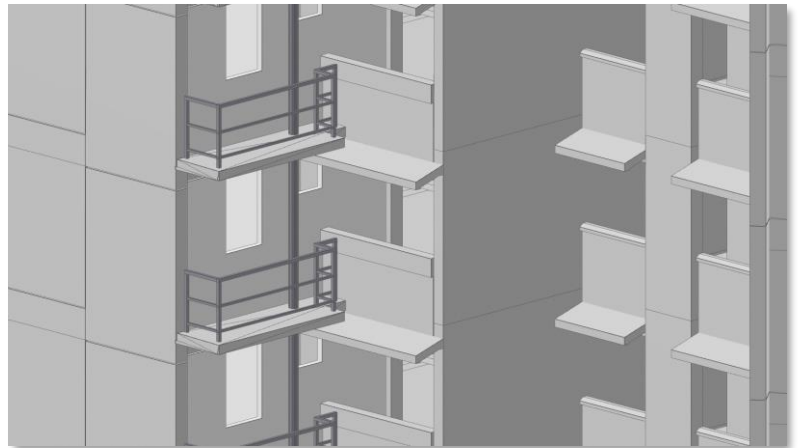

S4 – Fig 67 : Railing on AC Ledge (in relation to Building)

## ► By IFC Representation

IFC Entity: <b>lfcRailing</b>						
IFC SubType: N.A., BOLLARD, GUARDRAIL						
S/N	IFC-SG Property	Property Type	Type of Elements	Unit	Input Limitation	Examples
1	Height	Length	-	mm	No	1000
2	Material	Text	-	-	-	-
3	SafetyBarrier	Boolean	-	-	Yes	TRUE / FALSE
4	TypeOfBarrier	Text	-	-	No	-
5	IsLaminated	Boolean	-	-	Yes	TRUE / FALSE

## Ramp

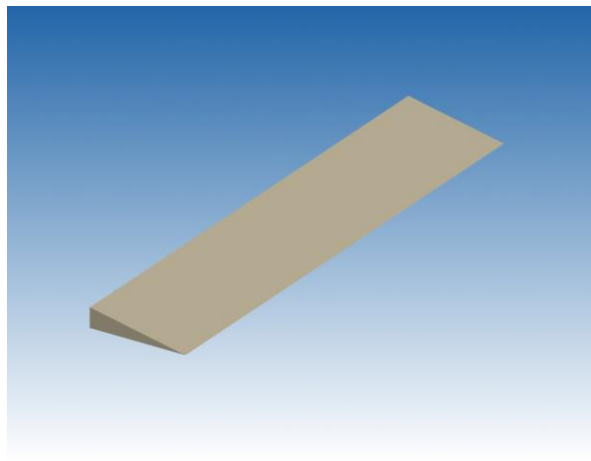

S4 – Fig 68 : Ramp

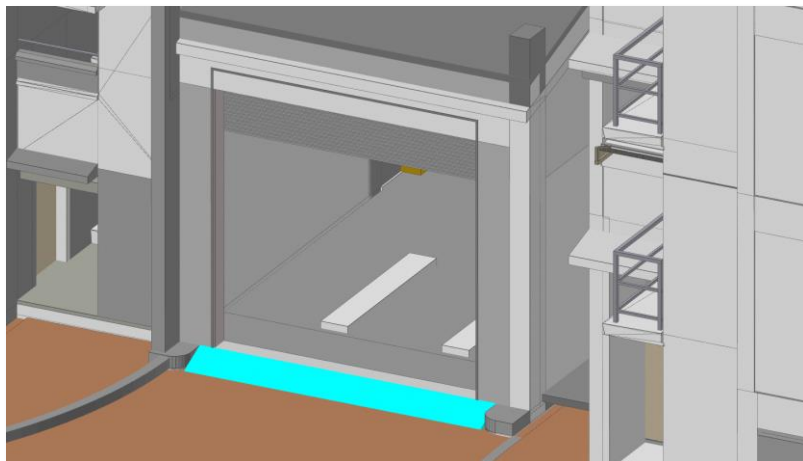

S4 – Fig 69 : Ramp in relation to Building

### ► By IFC Representation

IFC Entity: <b>lfcRamp</b>						
IFC SubType: CURVEDRAMP, FLAREDKERBRAMP, STRAIGHT_RUN_RAMP						
S/N	IFC-SG Property	Property Type	Type of Elements	Unit	Input Limitation	Examples
1	Gradient	Text	-	-	No	1:16
2	Width	Length	-	mm	No	1200
3	BarrierFreeAccessibility	Boolean	-	-	Yes	TRUE / FALSE
4	TransitionRamp	Boolean	-	-	Yes	TRUE / FALSE
5	Accessway	Boolean	-	-	Yes	TRUE / FALSE
6	Egress	Boolean	-	-	Yes	TRUE / FALSE
7	Ingress	Boolean	-	-	Yes	TRUE / FALSE
8	Vehicular	Boolean	-	-	Yes	TRUE / FALSE
9	Material	Text	-	-	No	-

#### Notes

- Any horizontal slab whose gradient is required for regulatory compliance purposes, including kerb ramp.
- It is possible to model the ramp in another default component in the native BIM software (e.g. SLAB or FLOOR component), and map it specially to the lfcRamp for submission purposes. Please refer to the [IFC-SG Resource Kit](#) for more info.

## Refuse Chute / Recyclables Chute

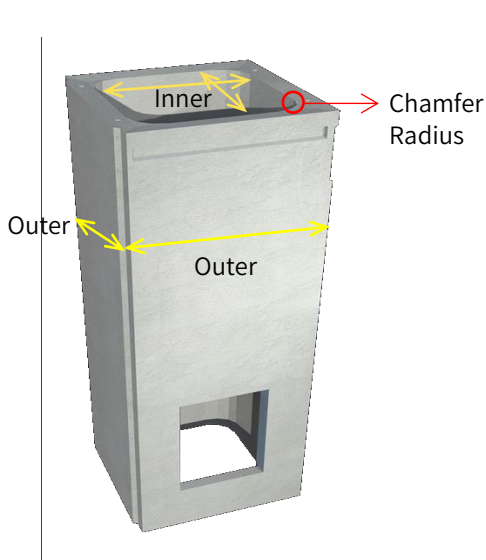

S4 – Fig 70 : Singular Refuse Chute

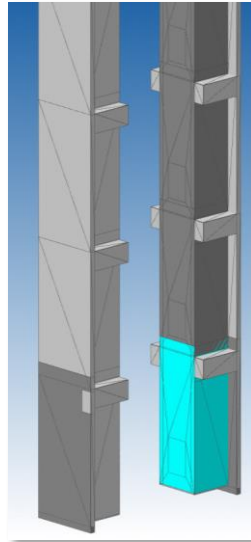

S4 – Fig 71 & 72 : Refuse Chute Stack in relation to Building

### ► By IFC Representation

IFC Entity: <b>IfcSpace</b>						
IFC SubType:						
S/N	IFC-SG Property	Property Type	Type of Elements	Unit	Input Limitation	Examples
1	SpaceName	Text	-	-	No	Refuse Chute Chamber, Recycle Refuse Chute Chamber
2	ConstructionMethod	Text	-	-	Yes	Precast
3	InnerLength	Length	-	mm	-	-
4	InnerWidth	Length	-	mm	-	-
5	OuterLength	Length	-	mm	-	-
6	OuterWidth	Length	-	mm	-	-
7	ChamferRadius	Length	-	mm	-	-

IFC Entity: <b>IfcWall</b>						
IFC SubType: REFUSECHUTE						
S/N	IFC-SG Property	Property Type	Type of Elements	Unit	Input Limitation	Examples
1	ConstructionMethod	Text	-	-	Yes	Precast

## Refuse Chute / Recyclables Chute

### ► By IFC Representation (continued from previous page)

IFC Entity: <b>IfcDoor</b>						
IFC SubType: ACCESSHATCH, RECYCLABLESCHUTEACCESSPANEL, RECYCLABLESCHUTEHOPPER, REFUSECHUTEACCESSPANEL, REFUSECHUTEHOPPER						
S/N	IFC-SG Property	Property Type	Type of Elements	Unit	Input Limitation	Examples
1	AirTight	Boolean	-	-	Yes	TRUE / FALSE
2	FireRating	Text	-	hr	No	½-hr , 1-hr etc.
3	SelfClosing	Boolean	-	-	Yes	TRUE / FALSE
4	VolumeControlled	Boolean	-	-	Yes	TRUE / FALSE
5	ClearWidth	Length	-	mm	No	335
6	ClearHeight	Length	-	mm	No	335
7	Material	Text	-	-	No	-
8	Thickness	Length	-	mm	No	80
9	StructuralWidth	Length	-	mm	No	490
10	StructuralHeight	Length	-	mm	No	710
11	FireAccessOpening	Boolean	-	-	Yes	TRUE / FALSE

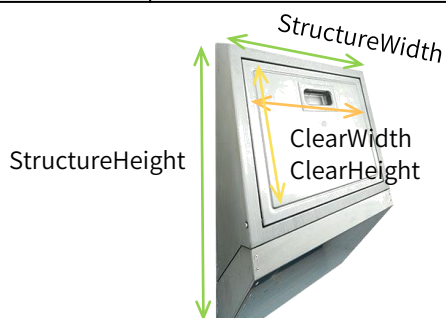

IFC Entity: <b>IfcFurniture</b>						
IFC SubType: REFUSECONTAINER, REFUSECOMPACTOR, RECYCLABLECONTAINER, RECYCLABLECOMPACTOR						
S/N	IFC-SG Property	Property Type	Type of Elements	Unit	Input Limitation	Examples
1	CompactionRatio	Text	-	-	-	2:01
2	Litre	Text	-	-	-	-
3	ColourCode	Text	-	-	-	-
4	BasePlateMaterial	Text	-	-	-	Mezzanine
5	BasePlateThickness	Length	-	mm	No	6
6	TailGateOrientation	Text	-	-	-	Inward Facing
7	HookUpPoint	Text	-	-	No	Outward Facing

## Refuse Handling Equipment

### ► By IFC Representation

IFC Entity: <a href="#">IfcTank</a>						
IFC SubType: REFUSEHANDLINGEQUIPMENT						
S/N	IFC-SG Property	Property Type	Type of Elements	Unit	Input Limitation	Examples
1	NominalCapacity	Volume	-	L, m <sup>3</sup>	-	1000 L, 40 m <sup>3</sup>
2	CompactionRatio	Text	-	-	-	-
3	EquipmentType	Text	-	-	-	-

IFC Entity: <a href="#">IfcFurniture</a>						
IFC SubType: REFUSEBIN						
S/N	IFC-SG Property	Property Type	Type of Elements	Unit	Input Limitation	Examples
1	-	-	-	-	-	-

# Road

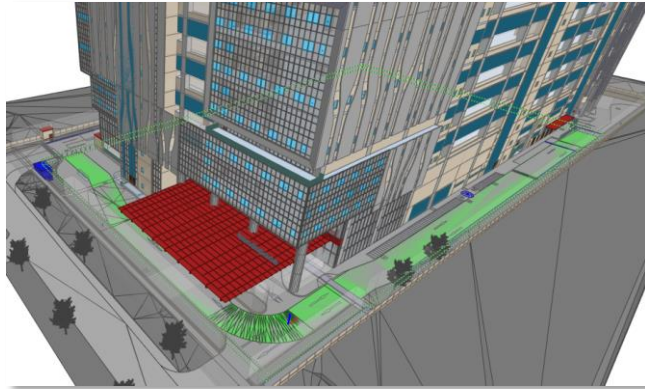

S4 – Fig 73 : Fire Engine Accessway

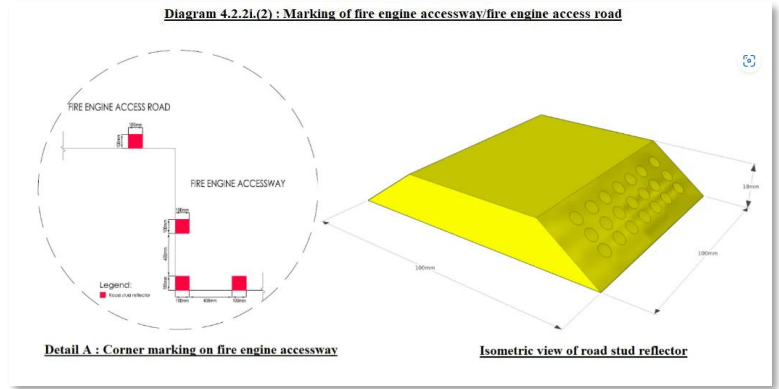

S4 – Fig 74 : Marking of Fire Engine Accessway

## ► Modelling Roads in IFC-SG

- Refers to driveways, carriageways, fire engine accessways, fire engine access roads and vehicular service roads for refuse collection vehicles, differentiated by IFC-SG properties
  - NEA’s Refuse Truck Access
  - NParks’ Planting Areas and Green Verges
  - SCDF’s Fire Engine Accessway / Access Road
- Spaces on roads, to complement LTA Roads, which are modelled under ‘IfcCivilElement’
  - Spaces are used for NEA, NParks and SCDF representations on the Road to reduce difficulties in modelling the road in multiple parts for multiple agencies]
- It is optional to indicate 3D arrows on the road as Egress and Ingress properties must be accurately indicated
- Refer to [“Ramp” component](#) for sloping roads

## ► By IFC Representation

IFC Entity: <b>IfcCivilElement</b>						
IFC SubType: DRIVEWAY						
S/N	IFC-SG Property	Property Type	Type of Elements	Unit	Input Limitation	Examples
1	LoadingCapacity	Text	-	tonnes	No	30 tonnes
2	DesignedVehicleMass	Real	-	-	-	-
3	Egress	Boolean	-	-	Yes	TRUE / FALSE
4	Ingress	Boolean	-	-	Yes	TRUE / FALSE
5	Material	Text	-	-	-	-
6	RoadCategory	Text	-	-	No	-

## Road

### ► By IFC Representation (continued from previous page)

IFC Entity: <b>IfcCivilElement</b>						
IFC SubType: CARRIAGEWAY						
S/N	IFC-SG Property	Property Type	Type of Elements	Unit	Input Limitation	Examples
1	Egress	Boolean	-	-	Yes	TRUE / FALSE
2	Ingress	Boolean	-	-	Yes	TRUE / FALSE
3	RoadCategory	Text	-	-	No	-
4	Material	Text	-	-	-	-

IFC Entity: <b>IfcSpace</b>						
IFC SubType: ACCESSWAY*, PARKINGACCESSWAY**, FIREENGINEACCESSROAD, FIREENGINEACCESSWAY, VEHICULARSERVICEROAD						
S/N	IFC-SG Property	Property Type	Type of Elements	Unit	Input Limitation	Examples
1	LoadingCapacity	Text	-	tonnes	No	30 tonnes
2	Material	Text	-	-	-	-

\* Note: ACCESSWAY refers to NEA’s refuse truck accessway only

\*\*Note: PARKINGACCESSWAY refers to LTA’s accessway to parking place

IFC Entity: <b>IfcBuildingElementProxy</b>						
IFC SubType: ACCESSPOINT						
S/N	IFC-SG Property	Property Type	Type of Elements	Unit	Input Limitation	
1	Width	Length	-	mm	-	-
2	Egress	Boolean	-	-	Yes	TRUE / FALSE
3	Ingress	Boolean	-	-	Yes	TRUE / FALSE
4	Vehicular	Boolean	-	-	Yes	TRUE / FALSE



# Road

## ► By IFC Representation (continued from previous page)

IFC Entity: <b>IfcCivilElement</b>						
IFC SubType: ROADKERB						
S/N	IFC-SG Property	Property Type	Type of Elements	Unit	Input Limitation	Examples
1	KerbType	Text	-	-	-	K2A
2	Thickness	Length	-	mm	-	-
3	Height	Length	-	mm	-	-
4	Material	Text	-	-	-	-

IFC Entity: <b>IfcBuildingElementProxy</b>						
IFC SubType: HUMP						
S/N	IFC-SG Property	Property Type	Type of Elements	Unit	Input Limitation	Examples
-	-	-	-	-	-	-

# Roof

## ► By IFC Representation (continued from previous page)

<b>IFC Entity: <a href="#">IfcRoof</a></b>						
<b>IFC SubType: N.A.</b>						
S/N	IFC-SG Property	Property Type	Type of Elements	Unit	Input Limitation	Examples
1	ConstructionMethod	Text	-	-	No	-
2	Material	Text	-	-	No	-

<b>IFC Entity: <a href="#">IfcSlab</a></b>						
<b>IFC SubType: ROOF</b>						
S/N	IFC-SG Property	Property Type	Type of Elements	Unit	Input Limitation	Examples
1	ConstructionMethod	Text	-	-	No	-
2	Material	Text	-	-	No	-

<b>IFC Entity: <a href="#">IfcCovering</a></b>						
<b>IFC SubType: ROOFING</b>						
S/N	IFC-SG Property	Property Type	Type of Elements	Unit	Input Limitation	Examples
1	ConstructionMethod	Text	-	-	No	-
2	Material	Text	-	-	No	-

## Sanitary Appliances

### ► Modelling Sanitary Appliances in IFC-SG

- For WELS (True / False), it refers to a minimum of **two ticks and above**. For more information, please refer to PUB’s Water Efficiency Label Rating here: <https://www.pub.gov.sg/wels/labelratings/typesoflabel>



S4 – Fig 75:  
 PUB WELS Rating

### ► By IFC Representation

- Bath**

IFC Entity: <a href="#">IfcSanitaryTerminal</a>						
IFC SubType: BATH						
S/N	IFC-SG Property	Property Type	Type of Elements	Unit	Input Limitation	Examples
1	WELS	Boolean	-	-	Yes	TRUE / FALSE

### ► By IFC Representation

- Bidet**

IFC Entity: <a href="#">IfcSanitaryTerminal</a>						
IFC SubType: BIDET						
S/N	IFC-SG Property	Property Type	Type of Elements	Unit	Input Limitation	Examples
1	WELS	Boolean	-	-	Yes	TRUE / FALSE

### ► By IFC Representation

- Shower**

IFC Entity: <a href="#">IfcSanitaryTerminal</a>						
IFC SubType: SHOWER						
S/N	IFC-SG Property	Property Type	Type of Elements	Unit	Input Limitation	Examples
1	WELS	Boolean	-	-	Yes	TRUE / FALSE

## Sanitary Appliances

### ► By IFC Representation

- **Urinal**

IFC Entity: <b>IfcSanitaryTerminal</b>						
IFC SubType: URINAL						
S/N	IFC-SG Property	Property Type	Type of Elements	Unit	Input Limitation	Examples
1	AmbulantDisabled	Boolean	-	-	Yes	TRUE / FALSE
2	ChildrenFriendly	Boolean	-	-	Yes	TRUE / FALSE
3	Mounting	Text	-	-	-	-
4	Waterless	Boolean	-	-	Yes	TRUE / FALSE
5	WELS	Boolean	-	-	Yes	TRUE / FALSE

### ► By IFC Representation

- **Wash Basin**

IFC Entity: <b>IfcSanitaryTerminal</b>						
IFC SubType: WASHHANDBASIN						
S/N	IFC-SG Property	Property Type	Type of Elements	Unit	Input Limitation	Examples
1	ChildrenFriendly	Boolean	-	-	Yes	TRUE / FALSE
2	Mounting	Text	-	-	No	-
3	WELS	Boolean	-	-	Yes	TRUE / FALSE

### ► By IFC Representation

- **Water Closet**

IFC Entity: <b>IfcSanitaryTerminal</b>						
IFC SubType: URINAL						
S/N	IFC-SG Property	Property Type	Type of Elements	Unit	Input Limitation	Examples
1	AmbulantDisabled	Boolean	-	-	Yes	TRUE / FALSE
2	BarrierFreeAccessibility	Boolean	-	-	Yes	TRUE / FALSE
3	ChildrenFriendly	Boolean	-	-	Yes	TRUE / FALSE
4	PanMounting	Text	-	-	-	-
5	ToiletPanType	Boolean	-	-	Yes	TRUE / FALSE
6	WELS	Boolean	-	-	Yes	TRUE / FALSE

## Sanitary Appliances

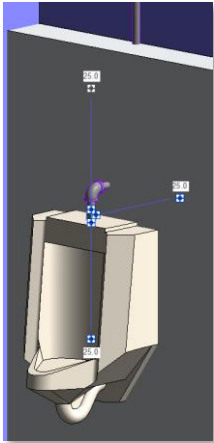

S4 – Fig 76:  
Urinal

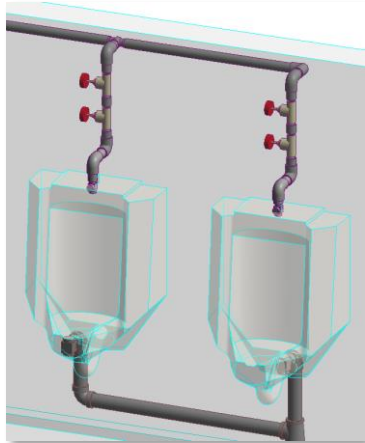

S4 – Fig 77:  
Urinal

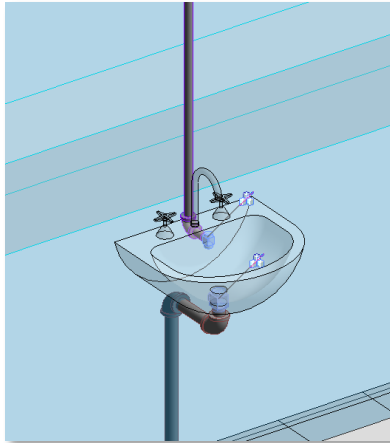

S4 – Fig 78:  
Wash Basin

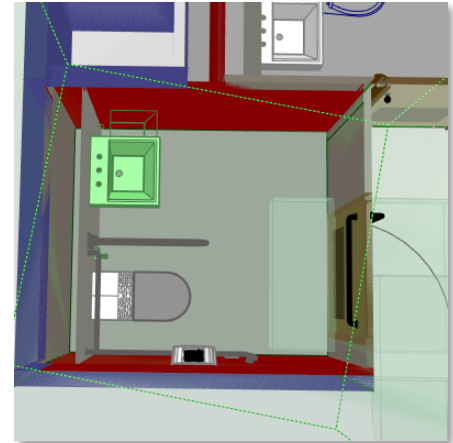

S4 – Fig 79:  
Wash Basin highlighted in Green

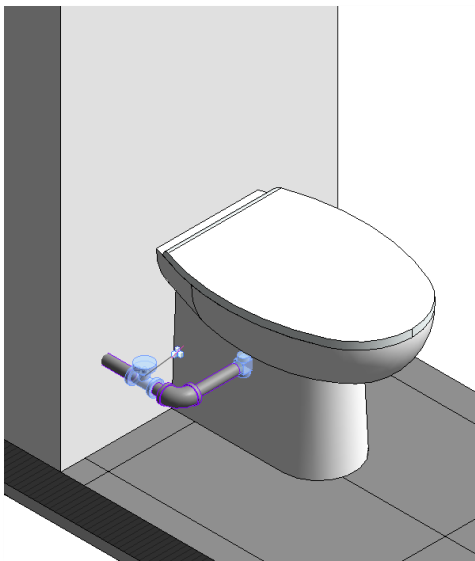

S4 – Fig 80: Water Closet

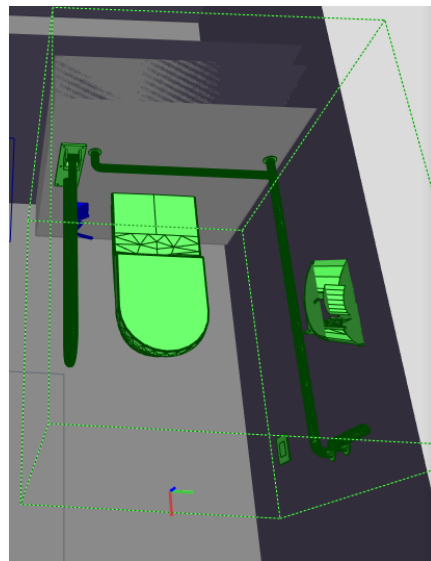

S4 – Fig 81:  
Water Closet for Ambulant Disabled

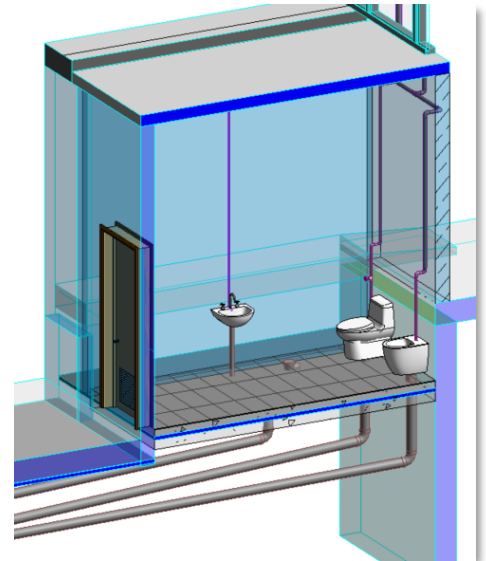

S4 – Fig 82: Water Closet

# Seating

## ► By IFC Representation

<b>IFC Entity:</b> <a href="#">IfcFurniture</a>						
<b>IFC SubType:</b> BENCH						
S/N	IFC-SG Property	Property Type	Type of Elements	Unit	Input Limitation	Examples
1	Capacity	Text	-	-	-	-

<b>IFC Entity:</b> <a href="#">IfcFurniture</a>						
<b>IFC SubType:</b> CHAIR						
S/N	IFC-SG Property	Property Type	Type of Elements	Unit	Input Limitation	Examples
1	-	-	-	-	-	-

### Notes

- To determine Occupancy Load for Assembly Spaces (e.g. Auditorium, Theatre), it is necessary to indicate the type of seating

## Security Lighting

### ► By IFC Representation

IFC Entity: <a href="#">IfcLightFixture</a>						
IFC SubType: SECURITYLIGHTING						
S/N	IFC-SG Property	Property Type	Type of Elements	Unit	Input Limitation	Examples
1	-	-	-	-	-	-

#### Notes

- Refers to emergency lighting to fulfil SCDF requirements

## Sensor

### ► Modelling Sensor in IFC-SG

- Level Sensor refers to sensors for monitoring refuse collected at the refuse chute.

### ► By IFC Representation

<b>IFC Entity:</b> <a href="#">IfcSensor</a>						
<b>IFC SubType:</b> LEVELSENSOR						
S/N	IFC-SG Property	Property Type	Type of Elements	Unit	Input Limitation	Examples
1	-	-	-	-	-	-

#### Notes

- Automatic sensors for fire protection (e.g. smoke detector, heat detector, flame detector etc.) do not need to be modelled. They are represented as a [Space parameter under “Automatic Fire Alarm System”](#).



## Shading Device

### ► By IFC Representation

IFC Entity: <a href="#">IfcShadingDevice</a>						
IFC SubType: LOUVREDPANEL						
S/N	IFC-SG Property	Property Type	Type of Elements	Unit	Input Limitation	Examples
1	ShadingDevice	Text	-	-	No	-

# Signage

## ► By IFC Representation

<b>IFC Entity:</b> <a href="#">IfcBuildingElementProxy</a>						
<b>IFC SubType:</b> SIGNAGE_EXIT						
S/N	IFC-SG Property	Property Type	Type of Elements	Unit	Input Limitation	Examples
1	MountingHeight	Length	-	mm	-	-

## Site



S4 – Fig 83 : Site / Site Boundary

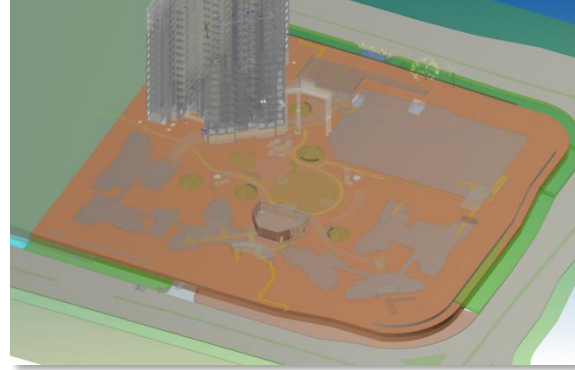

S4 – Fig 84 :  
 Site / Site Boundary in relation to Building

### ► By IFC Representation

IFC Entity: <a href="#">IfcSite</a>						
IFC SubType: N.A.						
S/N	IFC-SG Property	Property Type	Type of Elements	Unit	Input Limitation	Examples
1	NumberOfWorkers	Integer	-	-	-	-
2	TotalArea	Area	-	m <sup>2</sup>	No	-

## Site Boundary

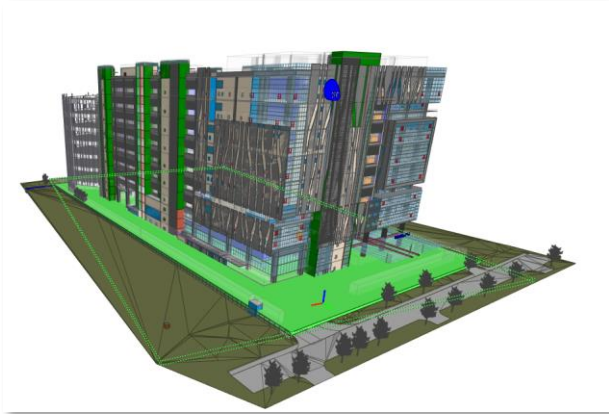

S4 – Fig 85 : Site / Site Boundary highlighted in Green

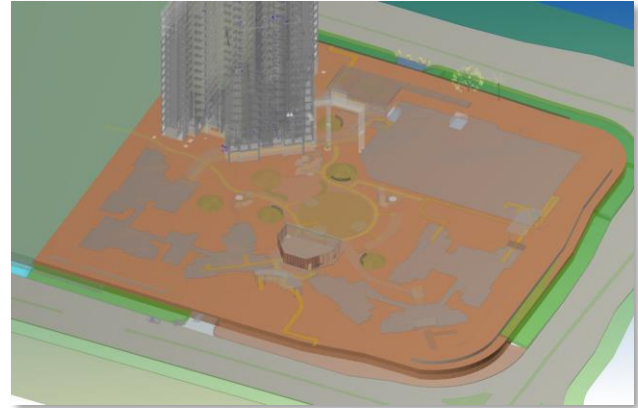

S4 – Fig 86 : Site / Site Boundary in Brown

### ► Hierarchy of Space

IfcSpace Sub-Type	Property Name	Definition
AREA_GFA	Name	The name of the area
	Development Use	URA development use of the area in question
	Building Typology	The building typology where the area is in
SPACE	Space Name	The name of the space
	Occupancy Type	SCDF definition of occupancy type for the space
SITEBOUNDARY	Broad Land Use	Referring to the broad land use of the entire site

### ► Site Boundary Dimension in IFC-SG

- The measurement of the site boundary will be extracted from the perimeter of the object.

### ► By IFC Representation

IFC Entity: <a href="#">IfcGeographicElement</a>						
IFC SubType: SITEBOUNDARY, CADASTRALLOT						
S/N	IFC-SG Property	Property Type	Type of Elements	Unit	Input Limitation	Examples
1	ApprovedSoilMixture	Boolean	-	N.A.	Yes	TRUE / FALSE
2	Area	Area	-	m <sup>2</sup>	No	N.A.

# Slab

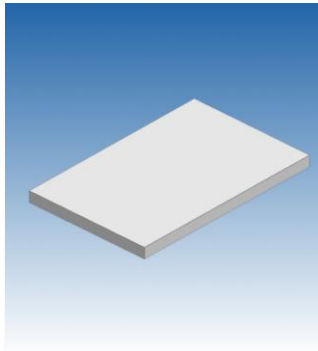

S4 – Fig 87 : Slab

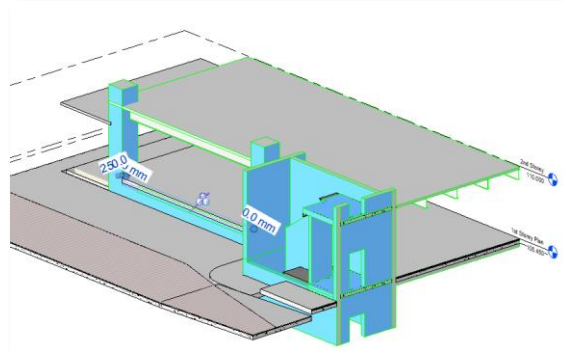

S4 – Fig 88 : Concrete Rectangular Slab

## ► Modelling Slab in IFC-SG

- All the slab elements shall be modelled in IFC-SG model with the necessary information required as stipulated in the tables below.
  - The nominal reinforcement for slab shall be indicated in IFC-SG parameters. Additional reinforcement to be presented in 2D drawings.
  - Civil defence shelter slab will need to be indicated as “Yes” in IFC-SG parameter “ShelterUsage” and substantiate with civil defence shelter reinforcement details in 2D drawings.
- 2D detail drawings are allowed for all slab reinforcement drawings with the indication of drawing number in the IFC-SG parameter “ReferTo2DDetail”.
- Cantilevered RC ledges should be modelled

## ► Slab Dimension and Reinforcement Definition

Slab Dimension and Reinforcement Definition	
1	QP can produce a set of 2D slab reinforcement drawings to present the arrangement of slab reinforcement for submission.
2	<p>The input for TopMain_nominal, TopDistribution_nominal, BottomMain_nominal &amp; BottomDistribution_nominal shall be "HXX-XXX" while "H" is a must, XX is the longitudinal reinforcement diameter and XXX is the spacing of longitudinal reinforcement (e.g. H32-150)</p> <div style="text-align: center;"> </div>
3	<p>The input for Stirrups shall be “HXX-XXX-XXX” while “H” is a must, XX are the transverse reinforcement diameter, 1<sup>st</sup> XXX is the longitudinal spacing of transverse reinforcement and 2<sup>nd</sup> XXX is the transverse spacing of transverse reinforcement.</p> <ul style="list-style-type: none"> <li>• Indicate the longitudinal spacing (main direction) and follow with transverse spacing (distribution direction) (e.g.H8-100-100)</li> </ul> <div style="text-align: center;"> </div>

# Slab

## ► Slab Dimension and Reinforcement Definition (continued from previous page)

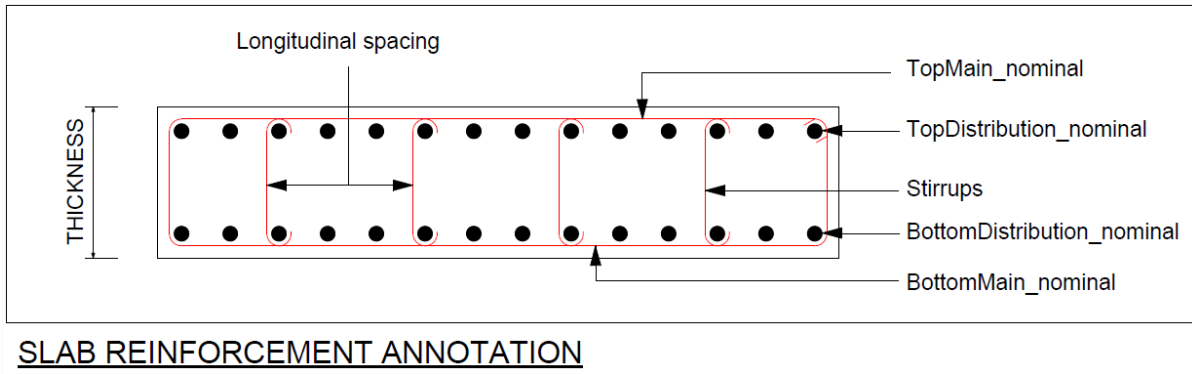

S4 – Fig 89 : Slab Reinforcement Annotation

## ► By IFC Representation

IFC Entity: <b>ifcSlab</b>						
IFC SubType: N.A., FLOOR, LANDING						
S/N	IFC-SG Property	Property Type	Type of Elements	Unit	Input Limitation	Examples
1	MaterialGrade	Text	All slabs	-	Yes	Refer to list <sup>^</sup>
2	ConstructionMethod	Text	All slabs	-	Yes	Refer to list <sup>^</sup>
3	ReferTo2DDetail	Text	When required / relevant	-	No	Dwg Number
4	ReinforcementSteelGrade	Text	All slabs	-	Yes	Refer to list <sup>^</sup>
5	ShelterUsage	Boolean	When required / relevant	-	Yes	TRUE / FALSE
6	SlabType	Text	All slabs	-	Yes	Refer to list <sup>^</sup>
7	Mark	Text	All slabs	-	No	S1, S01, PS01
8	Thickness	Length	All slabs	mm	No*	300
9	BottomDistribution_nominal	Text	When required / relevant	-	Yes	H25-150+H16-300
10	BottomMain_nominal	Text	When required / relevant	-	Yes	H25-150+H16-300
11	Stirrups	Text	When required / relevant	-	Yes	H10-150-300
12	StirrupsType	Text	Optional	-	Yes	Refer to list <sup>^</sup>
13	TopDistribution_nominal	Text	When required / relevant	-	Yes	H25-150+H16-300
14	TopMain_nominal	Text	When required / relevant	-	Yes	H32-150+H20-300
15	WeldedMesh	Boolean	All slabs	-	Yes	TRUE / FALSE

\* Parameter is populated from the dimensions of BIM elements modelled.

<sup>^</sup> List can be found [here](#).

# Slab

## ► By IFC Representation (continued from previous page)

IFC Entity: <b>IfcSlab</b>						
IFC SubType: N.A., FLOOR, LANDING						
S/N	IFC-SG Property	Property Type	Type of Elements	Unit	Input Limitation	Examples
16	Accreditation_PAS	Boolean	When required / relevant	-	Yes	TRUE / FALSE
17	LoadBearing	Boolean	When required / relevant	-	Yes	TRUE / FALSE
18	Thickness	Length	All slabs	mm	No*	300
19	MechanicalConnectionType	Text	-	-	No	Flexible Loops
20	TypeDesignator	Text	-	-	No	Double T Slab, Hollowcore
21	LatticeGirderReinforcement	Boolean	When required / relevant	-	Yes	TRUE / FALSE



\* Parameter is populated from the dimensions of BIM elements modelled.

^ List can be found [here](#).

## ► Example of Slab (RC Household Shelter Slab) Element Input

250mm thick RC Cast-In-Situ Household Shelter Slab	IFC Entity: <b>IfcSlab</b>			
	IFC SubType: N.A.			
<ul style="list-style-type: none"> <li>• Mark – HS1</li> <li>• Concrete grade C32/40</li> <li>• Two way slab</li> <li>• Top Reinforcement H10-100 bothway</li> <li>• Bottom Reinforcement H10-100 bothway</li> <li>• Shear link H8-600</li> </ul>	S/N	IFC-SG Property	Examples	
		1	MaterialGrade	C32/40
		2	ConstructionMethod	CIS
		3	ReferTo2DDetail	Dwg 19588-HS-DT-1
		4	ReinforcementSteelGrade	500B
		5	ShelterUsage	Yes
		6	SlabType	Two way
		7	Mark	HS1
		8	Thickness	200
		9	BottomDistribution_nominal	H10-100
		10	BottomMain_nominal	H10-100
		11	Stirrups	H8-600
		12	StirrupsType	CL
		13	TopDistribution_nominal	H10-100
	14	TopMain_nominal	H10-100	

# Soffit

Legend:  Architecture  C&S  M&E

## ► By IFC Representation

IFC Entity: <a href="#">IfcCovering</a>						
IFC SubType: SOFFIT						
S/N	IFC-SG Property	Property Type	Type of Elements	Unit	Input Limitation	Examples
1	FireRating	Text	-	-	No	-



# Space

## ► About

As ‘IfcSpace’ is the most common component across all agencies, it is broken down into 2 sub-sections for ease of understanding. ‘IfcSpace’ consists of:

- Space (Area Schemes)
- Space (Usage)

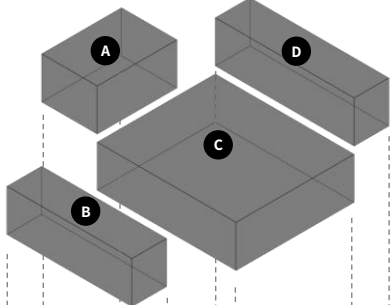
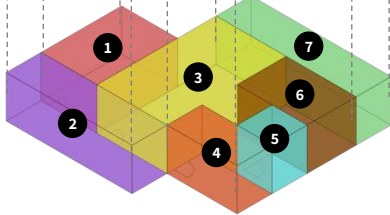
	Space Definition	Requirements Involved	Definition	Conceptual Illustration (Not to Scale)
1	<b>Space (Area Schemes)</b>	<ul style="list-style-type: none"> <li>• URA’s GFA calculations</li> <li>• NEA’s refuse output</li> <li>• LTA’s parking provisions</li> </ul>	<ul style="list-style-type: none"> <li>• For checks based on GFA only</li> <li>• Spaces will need to be manually verged for 5 types of ‘IfcSpace’ sub-types:                             <ol style="list-style-type: none"> <li>1) AREA_GFA</li> <li>2) AREA_LANDSCAPE</li> <li>3) AREA_CONNECTIVITY</li> <li>4) AREA_STRATA</li> <li>5) AREA_VERIFICATION</li> </ol> </li> </ul> <p>In Revit and ArchiCAD, these correspond to Area Schemes and Zones respectively.</p> <p>Only relevant categories for each floor plate need to be verged. For example, typical floor plates of Flats/Condominiums may only require AREA_GFA and AREA_STRATA to be verged.</p> <p>Properties and other information on Space (Area Schemes) can be found on <a href="#">Page 326</a></p>	<p>Residential (Non-Landed) Unit                      See <i>input example on subsequent pages</i></p> <p><b>SPACE (AREA SCHEME)</b></p>  <p>+</p>  <p><b>SPACE (USAGE)</b></p> <p>S4 – Fig 90:                      Space Conceptual Illustration</p>
2	<b>Space (Usage)</b>	<ul style="list-style-type: none"> <li>• BCA’s Accessibility requirements</li> <li>• LTA’s Minimum Driveway Width</li> <li>• NEA’s Sanitary Provisions</li> <li>• PUB’s Minimum Platform Levels</li> <li>• SCDF’s Exit Requirements</li> </ul>	<ul style="list-style-type: none"> <li>• For checks based on Occupancy Type, Building Typology and Space Usage</li> <li>• As cross-agency spaces have been harmonized and standardised, each space only require 2 ‘IfcSpace’ properties to address their usage requirements:                             <ol style="list-style-type: none"> <li>1) SpaceName</li> <li>2) Occupancy Type</li> </ol> </li> </ul> <p>Properties and other information on Space (Usage) can be found at <a href="#">Page 309</a></p>	

## ► Hierarchy of Space

IfcSpace Sub-Type	Property Name	Definition
SPACE	Space Name	The name of the space
	Occupancy Type	SCDF definition of occupancy type for the space
SITEBOUNDARY	Broad Land Use	Referring to the broad land use of the entire site

## Space (Area Requirements)

The Area Requirements categorisation facilitates the organization of drawings within a BIM model. Within these layers, there are containers for data, also referred to as properties. When these layers and properties are accurately populated, they facilitate the computation of information and rule-checking, such as aggregate GFA, GFA quantum, and the refuse output corresponding to the proposed development.

### ► Example of Space (Area Requirements)

- **Typical Residential Floor**

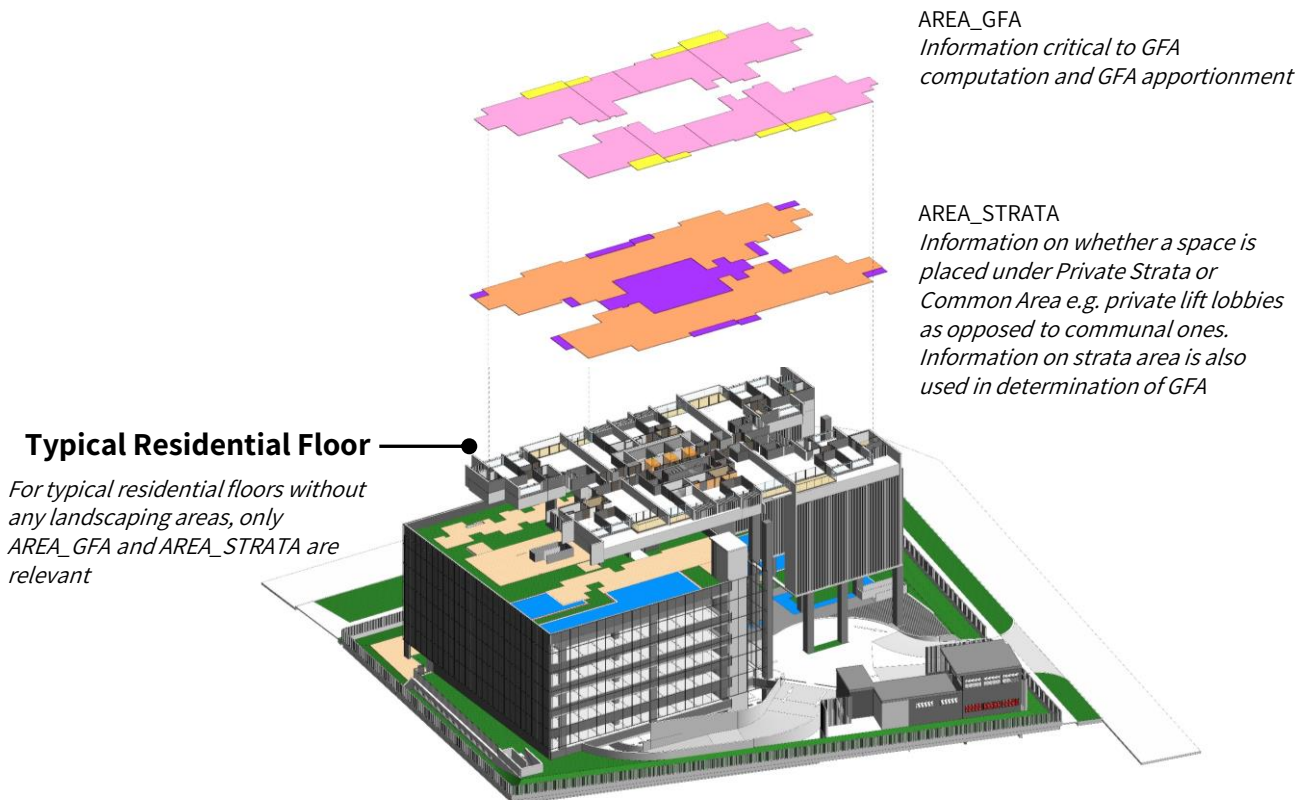

## ► Example of Space (Area Requirements)

- Sky Terrace Floor

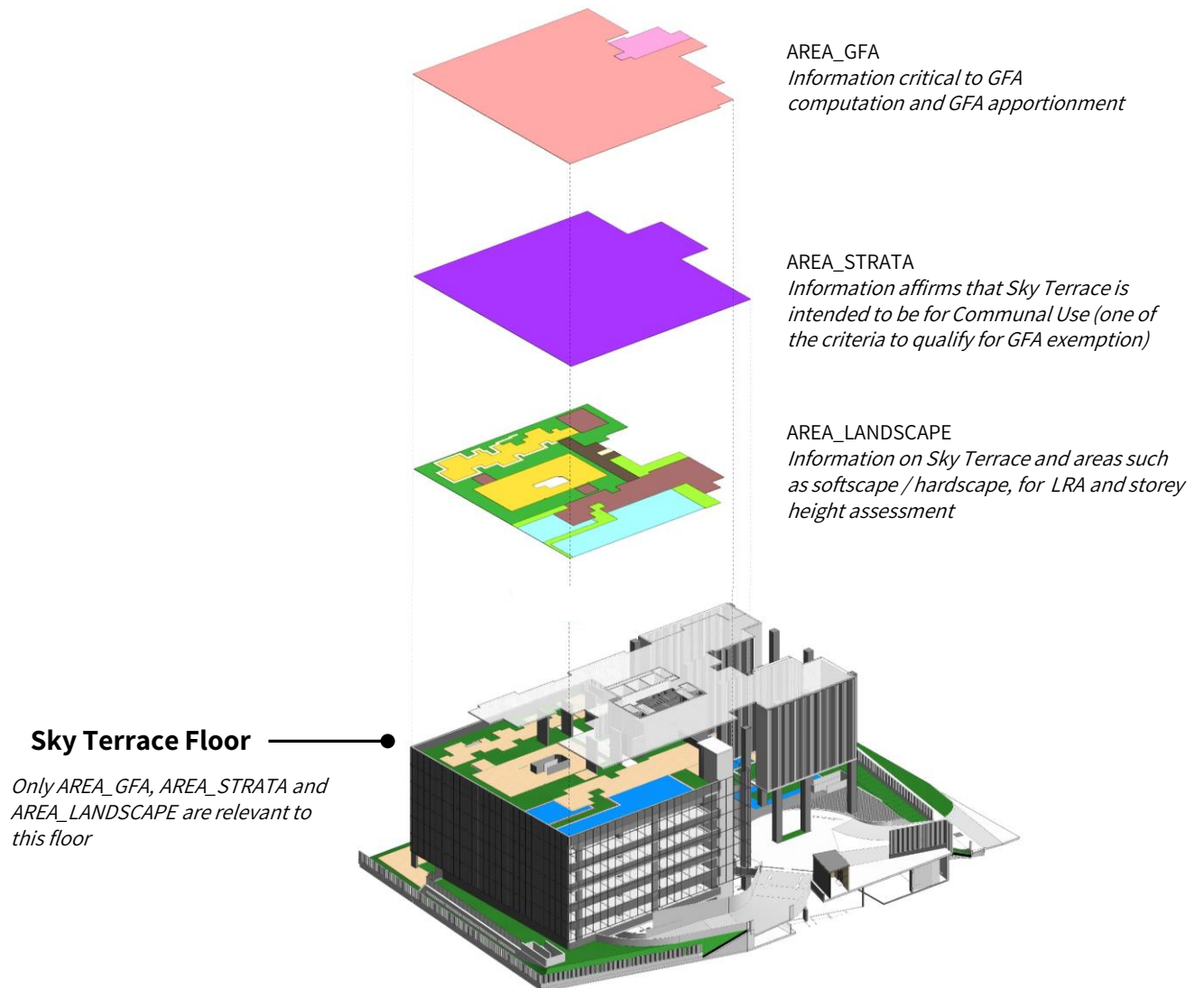

# Space (Area Requirements)

- AREA\_GFA
- AREA\_STRATA
- AREA\_LANDSCAPE
- AREA\_CONNECTIVITY
- AREA\_VERIFICATION

## AREA\_GFA

This layer is for the verging of spaces where specific properties (matched with the corresponding geometries of such space) need to be captured for purposes of regulatory checks. For example determination of proposed uses, quantum controls and GFA exemption criteria.

Only properties with a prefix “AGF” are relevant to this layer.

AGF\_DevelopmentUse must be keyed in for all areas, except where such area(s) needs to be attributed to two or more Development Uses; then it should be left blank.

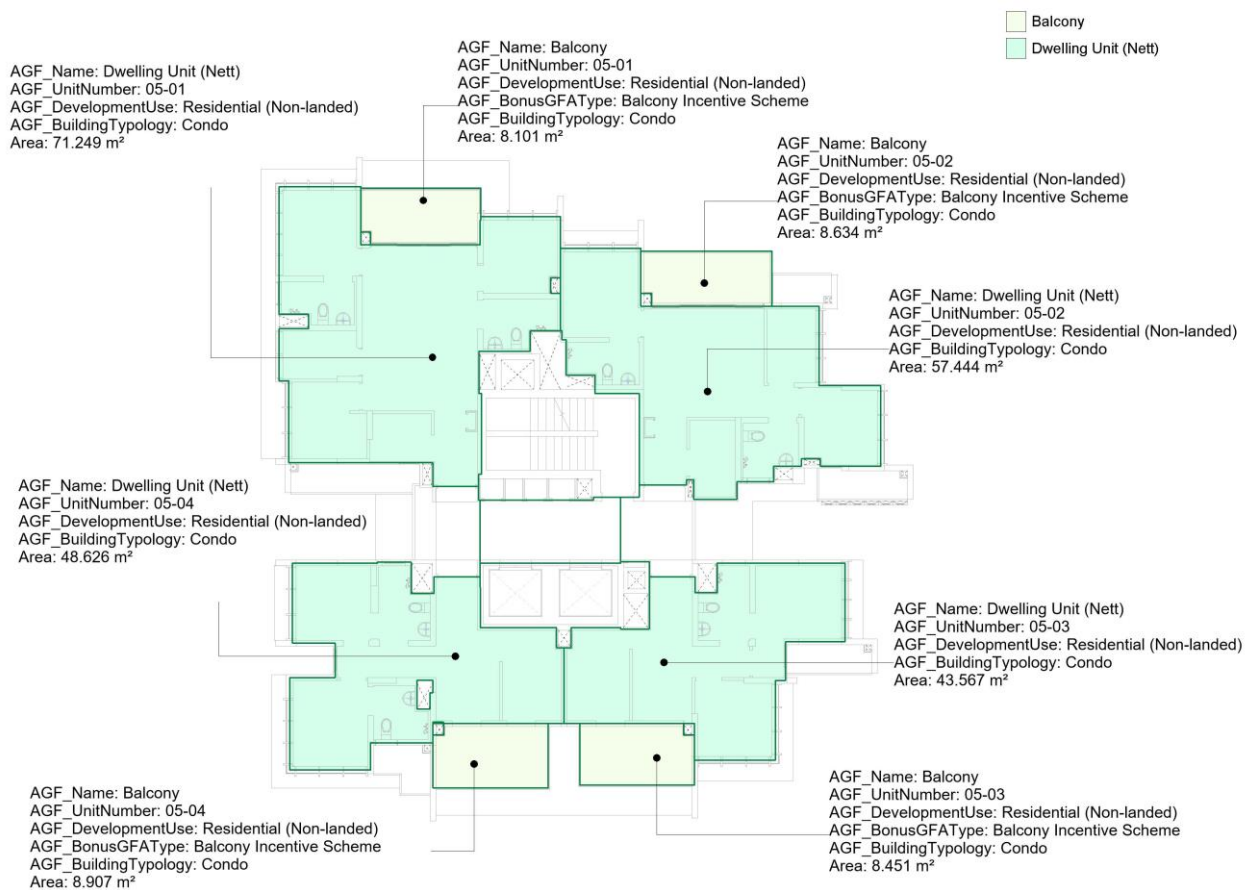

## Space (Area Requirements)

- AREA\_GFA
- AREA\_STRATA
- AREA\_LANDSCAPE
- AREA\_CONNECTIVITY
- AREA\_VERIFICATION

### AREA\_STRATA

This layer is for the verging of strata related areas.

Only properties with a prefix “AST” are relevant to this layer.

A key property to this layer is AST\_AreaType, as it provides information on whether a space is intended to be private strata or common area.

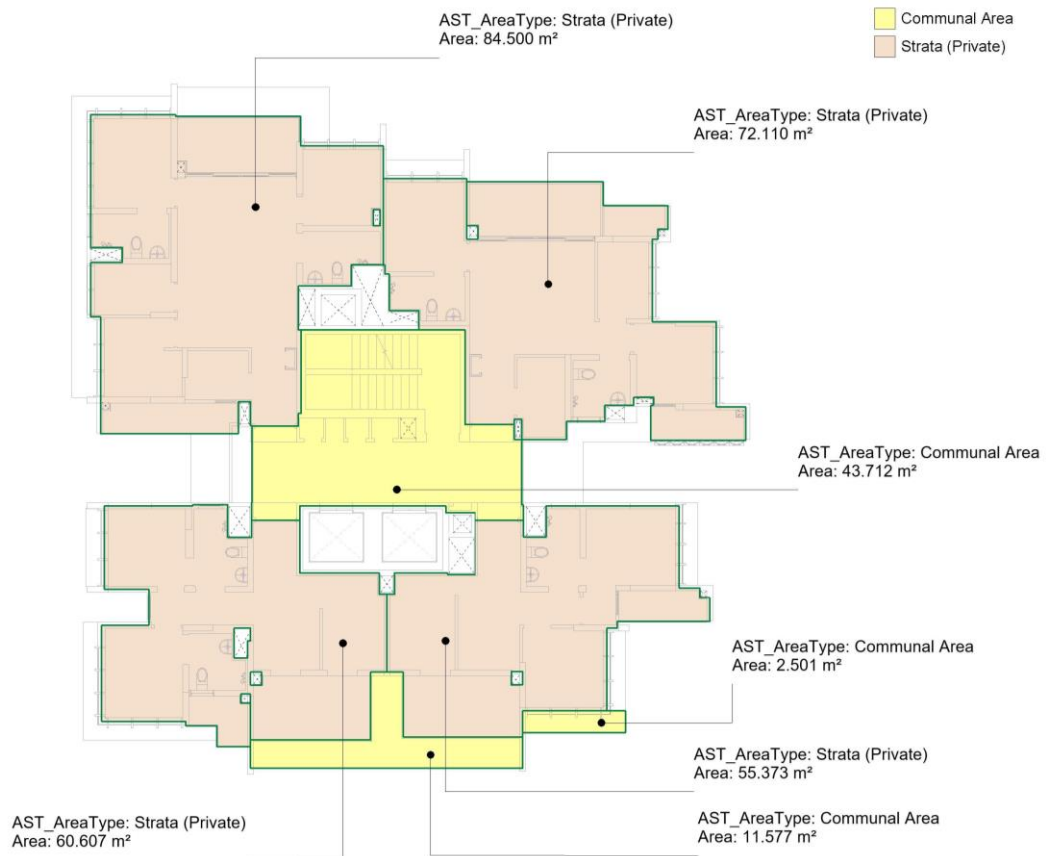

## Space (Area Requirements)

AREA\_GFA  
AREA\_STRATA  
**AREA\_LANDSCAPE**  
AREA\_CONNECTIVITY  
AREA\_VERIFICATION

### **AREA\_LANDSCAPE**

This layer is for the verging of landscape related areas. (such as Green Buffer and Peripheral Planting Strip)  
It also allows types of landscaping (such as shrubs or footpaths) to be organised within greenery features, such as Sky Terraces or Communal Ground Gardens.  
Only properties with a prefix “ALS” are relevant to this layer.

AREA\_GFA  
AREA\_STRATA  
AREA\_LANDSCAPE  
**AREA\_CONNECTIVITY**  
AREA\_VERIFICATION

### **AREA\_CONNECTIVITY**

This layer is for the verging of connectivity related areas.  
It facilitates the assessment of pedestrian/cyclist access within and around the development. It also helps to identify public spaces, such as Privately-Owned Public Spaces (POPS) which is registered as “PublicSpaceNode” under ACN\_ConnectivityType.  
Only properties with a prefix “ACN” are relevant to this layer.

AREA\_GFA  
AREA\_STRATA  
AREA\_LANDSCAPE  
AREA\_CONNECTIVITY  
**AREA\_VERIFICATION**

### **AREA\_VERIFICATION**

This layer is for the verging of included/excluded GFA. [Note that this is to facilitate GFA verification for the time-being. This also allows URA to identify more clearly areas which QPs are seeking GFA exemption, for more expedient assessment]  
Only properties with a prefix “AVF” are relevant to this layer.

# Space (Usage)

## ► Example of Space (Usage) Input

Conceptual Diagrams (Not To Scale)

### Residential (Non-Landed) Unit

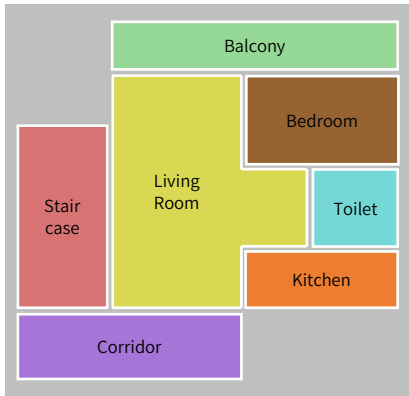

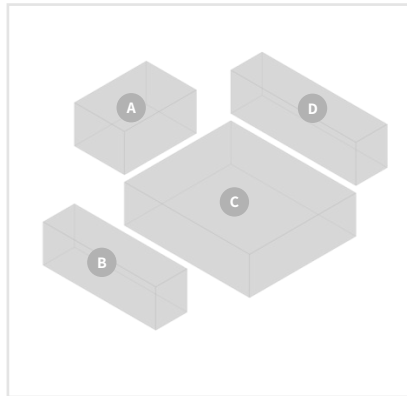

### SPACE (AREA SCHEME)



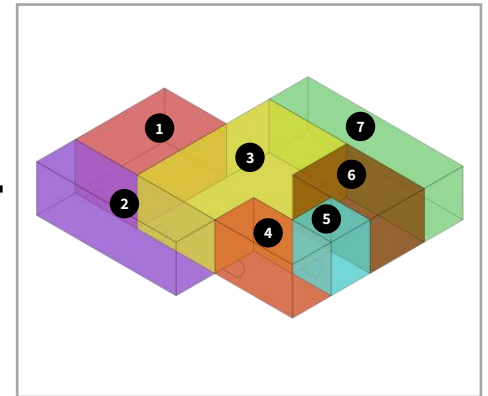

### SPACE (USAGE)



<b>Residential (Non-Landed) Unit</b> <b>Space (Usage)</b> 1. Staircase 	<b>IFC Entity:</b> <a href="#">IfcSpace</a>		
	<b>IFC SubType:</b> N.A.		
	S/N	IFC-SG Property	Value
	1	SpaceName	Staircase
	2	OccupancyType	Multi-Unit Residential

<b>Residential (Non-Landed) Unit</b> <b>Space (Usage)</b> 2. Corridor 	<b>IFC Entity:</b> <a href="#">IfcSpace</a>		
	<b>IFC SubType:</b> N.A.		
	S/N	IFC-SG Property	Value
	1	SpaceName	Corridor
	2	OccupancyType	Multi-Unit Residential

<b>Residential (Non-Landed) Unit</b> <b>Space (Usage)</b> 3. Living Room 	<b>IFC Entity:</b> <a href="#">IfcSpace</a>		
	<b>IFC SubType:</b> N.A.		
	S/N	IFC-SG Property	Value
	1	SpaceName	Living Room
	2	OccupancyType	Multi-Unit Residential

<b>Residential (Non-Landed) Unit</b> <b>Space (Usage)</b> 4. Kitchen 	<b>IFC Entity:</b> <a href="#">IfcSpace</a>		
	<b>IFC SubType:</b> N.A.		
	S/N	IFC-SG Property	Value
	1	SpaceName	Kitchen
	2	OccupancyType	Multi-Unit Residential

## Space (Usage)

### ► Example of Space (Usage) Input

Continued from previous page

<b>Residential (Non-Landed) Unit</b>  <b>Space (Usage)</b>  5. Toilet	<b>IFC Entity:</b> <a href="#">IfcSpace</a>		
	<b>IFC SubType:</b> N.A.		
	S/N	IFC-SG Property	Value
	1	SpaceName	Toilet
	2	OccupancyType	Multi-Unit Residential



<b>Residential (Non-Landed) Unit</b>  <b>Space (Usage)</b>  6. Bedroom	<b>IFC Entity:</b> <a href="#">IfcSpace</a>		
	<b>IFC SubType:</b> N.A.		
	S/N	IFC-SG Property	Value
	1	SpaceName	Bedroom
	2	OccupancyType	Multi-Unit Residential



<b>Residential (Non-Landed) Unit</b>  <b>Space (Usage)</b>  7. Balcony	<b>IFC Entity:</b> <a href="#">IfcSpace</a>		
	<b>IFC SubType:</b> N.A.		
	S/N	IFC-SG Property	Value
	1	SpaceName	Balcony
	2	OccupancyType	Multi-Unit Residential





## Modelling IFC-SG (Space) for URA



## Modelling IFC-SG (Space – Area Requirement)

IFC Entity: IfcSpace					
IFC SubType: AREA_GFA					
	IFC-SG Property	Actual Values			
1	AGF_DevelopmentUse [Text]	<ul style="list-style-type: none"> <li>Agriculture</li> <li>Beach Area</li> <li>Business Park</li> <li>Business 1</li> <li>Business 2</li> <li>Cemetery</li> <li>Civic &amp; Community Institution</li> <li>Commercial</li> </ul>	<ul style="list-style-type: none"> <li>Educational Institution</li> <li>Health &amp; Medical Care</li> <li>Hotel</li> <li>Open Space</li> <li>Park</li> <li>Place of Worship</li> <li>Port/Airport</li> <li>Rapid Transit</li> </ul>	<ul style="list-style-type: none"> <li>Reserve Site</li> <li>Residential (Landed)</li> <li>Residential (Non-landed)</li> <li>Road</li> <li>Special Use</li> <li>Sports &amp; Recreation</li> <li>Transport Facilities</li> </ul>	<ul style="list-style-type: none"> <li>Utility</li> <li>Waterbody</li> </ul>
2 a	AGF_Name [Text]  (When AGF_DevelopmentUse = “Residential (Non-landed)”)	<ul style="list-style-type: none"> <li>Airwell</li> <li>ATM Kiosk</li> <li>Balcony</li> <li>Bicycle Parking Space</li> <li>Bin Centre</li> <li>Bin Point</li> <li>Cable Chamber</li> <li>Car Parking Lot (Mechanised)</li> <li>Car Porch/Garage</li> <li>Conserved Bungalow</li> <li>Control Room/ Centre</li> <li>Courtyard</li> <li>Discharge Valve Chamber</li> <li>Driveways</li> <li>Dwelling Unit (Nett)</li> </ul>	<ul style="list-style-type: none"> <li>Entrance Canopy</li> <li>Gondola and working platform</li> <li>Guardhouse / Sentry Post</li> <li>Indoor Recreation Space</li> <li>Letter Box Area</li> <li>Lift Lobby</li> <li>Lift Motor Room</li> <li>Loft</li> <li>M&amp;E Room (enclosed)</li> <li>M&amp;E Services (non-load bearing covering above)</li> <li>M&amp;E Space (unenclosed)</li> </ul>	<ul style="list-style-type: none"> <li>Pavilion</li> <li>Pick-up/ Drop-off Point</li> <li>Private Enclosed Space</li> <li>Privately Owned Public Space</li> <li>Refuse Chute Chamber</li> <li>Refuse Room</li> <li>Residual Area and Corridor (Carpark Floor)</li> <li>Roof Terrace</li> </ul>	<ul style="list-style-type: none"> <li>Serviced Apartment Unit (Nett)</li> <li>Storey Shelter</li> <li>Students' Hostel</li> <li>Swimming Pool</li> <li>Tennis Court</li> <li>Vending Machine Kiosk</li> <li>Visitors' Hostel</li> </ul>
2 b	AGF_Name [Text]  (When AGF_DevelopmentUse = “Residential (Landed)”)	<ul style="list-style-type: none"> <li>Airwell</li> <li>Balcony</li> <li>Bathroom</li> <li>Bedroom</li> <li>Bin Centre</li> <li>Bin Point</li> <li>Bomb Shelter</li> <li>Car Porch/Garage</li> <li>Courtyard</li> </ul>	<ul style="list-style-type: none"> <li>Dining Room</li> <li>Discharge Valve Chamber</li> <li>Family area</li> <li>Household Shelter</li> <li>Kitchen</li> </ul>	<ul style="list-style-type: none"> <li>Lift Lobby</li> <li>Lift Motor Room</li> <li>Living Room</li> <li>Meter Compartment</li> <li>Roof Terrace</li> </ul>	<ul style="list-style-type: none"> <li>Storey Shelter</li> <li>Swimming Pool</li> </ul>

## Modelling IFC-SG (Space) for URA



# Modelling IFC-SG (Space – Area Requirement)

IFC Entity: IfcSpace					
IFC SubType: AREA_GFA					
	IFC-SG Property	Actual Values			
2 c	<b>AGF_Name [Text]</b>  (When <b>AGF_DevelopmentUse =                      “Business 1”</b> )	<ul style="list-style-type: none"> <li>Airwell</li> <li>ATM Kiosk</li> <li>Balcony</li> <li>Bicycle Parking Space</li> <li>Bin Centre</li> <li>Bin Point</li> <li>Cable Chamber</li> <li>Car Parking Lot (Mechanised)</li> <li>Cloud Kitchen</li> <li>Control Room/ Centre</li> <li>Core Media</li> <li>Courtyard</li> <li>Data centres/ Server areas/ IT equipment</li> <li>Discharge Valve Chamber</li> <li>Driveways</li> </ul>	<ul style="list-style-type: none"> <li>E-Business</li> <li>End of Trip Facilities</li> <li>Entrance Canopy</li> <li>Gondola and working platform</li> <li>Guardhouse / Sentry Post</li> <li>Industrial Canteen</li> <li>Industrial Training Room</li> <li>Kitchen/ Pantry/ Food Preparation area/ Food Stall</li> <li>Letter Box Area</li> <li>Lift Lobby</li> <li>Lift Motor Room</li> <li>Loading and Unloading Bay</li> <li>Loft</li> </ul>	<ul style="list-style-type: none"> <li>M&amp;E Floor</li> <li>M&amp;E Room (enclosed)</li> <li>M&amp;E Services (non-load bearing covering above)</li> <li>M&amp;E Space (unenclosed)</li> <li>Media/ Audio Visual/ Filming/ Streaming</li> <li>Meeting Room</li> <li>Office</li> <li>On-Site Food Waste Treatment Area</li> <li>Pavilion</li> <li>Pick-up/ Drop-off Point</li> <li>Printing / Publishing</li> <li>Privately Owned Public Space</li> <li>Refuse Chute Chamber</li> </ul>	<ul style="list-style-type: none"> <li>Refuse Room</li> <li>Residual Area and Corridor (Carpark Floor)</li> <li>Roof Terrace</li> <li>Storey Shelter</li> <li>Swimming Pool</li> <li>Vending Machine Kiosk</li> <li>Warehouse/ Storage / Staging</li> <li>Workshop/ Manufacturing / Production/ Processing/ Yard</li> </ul>
2 d	<b>AGF_Name [Text]</b>  (When <b>AGF_DevelopmentUse =                      “Business 2”</b> )	<ul style="list-style-type: none"> <li>Airwell</li> <li>Assembly</li> <li>ATM Kiosk</li> <li>Balcony</li> <li>Bicycle Parking Space</li> <li>Bin Centre</li> <li>Bin Point</li> <li>Cable Chamber</li> <li>Car Parking Lot (Mechanised)</li> <li>Cloud Kitchen</li> <li>Control Room/ Centre</li> <li>Core Media</li> <li>Courtyard</li> <li>Data centres/ Server areas/ IT equipment</li> </ul>	<ul style="list-style-type: none"> <li>Discharge Valve Chamber</li> <li>Driveways</li> <li>E-Business</li> <li>End of Trip Facilities</li> <li>Entrance Canopy</li> <li>Gondola and working platform</li> <li>Guardhouse / Sentry Post</li> <li>Industrial Canteen</li> <li>Industrial Training Room</li> <li>Kitchen/ Pantry/ Food Preparation area/ Food Stall</li> <li>Letter Box Area</li> <li>Lift Lobby</li> </ul>	<ul style="list-style-type: none"> <li>Lift Motor Room</li> <li>Loading and Unloading Bay</li> <li>Loft</li> <li>M&amp;E Floor</li> <li>M&amp;E Room (enclosed)</li> <li>M&amp;E Services (non-load bearing covering above)</li> <li>M&amp;E Space (unenclosed)</li> <li>Media/ Audio Visual/ Filming/ Streaming</li> <li>Meeting Room</li> <li>Office</li> <li>On-Site Food Waste Treatment Area</li> <li>Pavilion</li> <li>Pick-up/ Drop-off Point</li> <li>Printing / Publishing</li> <li>Privately Owned Public Space</li> </ul>	<ul style="list-style-type: none"> <li>Refuse Chute Chamber</li> <li>Refuse Room</li> <li>Repair / Servicing</li> <li>Residual Area and Corridor (Carpark Floor)</li> <li>Roof Terrace</li> <li>Storey Shelter</li> <li>Swimming Pool</li> <li>Vending Machine Kiosk</li> <li>Warehouse/ Storage / Staging</li> <li>Workshop/ Manufacturing / Production/ Processing/ Yard</li> </ul>



## Modelling IFC-SG (Space – Area Requirement)

IFC Entity: IfcSpace					
IFC SubType: AREA_GFA					
	IFC-SG Property	Actual Values			
2 e	<b>AGF_Name [Text]</b>  (When <b>AGF_DevelopmentUse =</b> <b>“Business Park”</b> )	<ul style="list-style-type: none"> <li>• Airwell</li> <li>• ATM Kiosk</li> <li>• Balcony</li> <li>• Bicycle Parking Space</li> <li>• Bin Centre</li> <li>• Bin Point</li> <li>• Cable Chamber</li> <li>• Car Parking Lot (Mechanised)</li> <li>• Central Distribution Centre</li> <li>• Cloud Kitchen</li> <li>• Control Room/ Centre</li> <li>• Core media</li> <li>• Courtyard</li> <li>• Data centres/ Server areas/ IT equipment</li> </ul>	<ul style="list-style-type: none"> <li>• Data processing</li> <li>• Discharge Valve Chamber</li> <li>• Driveways</li> <li>• E-Business</li> <li>• End of Trip Facilities</li> <li>• Entrance Canopy</li> <li>• Gondola and working platform</li> <li>• Guardhouse / Sentry Post</li> <li>• Industrial Canteen</li> <li>• Industrial Training Room</li> <li>• Kitchen/ Pantry/ Food Preparation area/ Food Stall</li> <li>• Letter Box Area</li> <li>• Lift Lobby</li> <li>• Lift Motor Room</li> </ul>	<ul style="list-style-type: none"> <li>• Loading and Unloading Bay</li> <li>• Loft</li> <li>• M&amp;E Floor</li> <li>• M&amp;E Room (enclosed)</li> <li>• M&amp;E Services (non-load bearing covering above)</li> <li>• M&amp;E Space (unenclosed)</li> <li>• Manufacturing (High Tech)</li> <li>• Office</li> <li>• On-Site Food Waste Treatment Area</li> <li>• Outdoor Refreshment Area</li> <li>• Outdoor Refreshment Kiosk</li> <li>• Pavilion</li> <li>• Pick-up/ Drop-off Point</li> <li>• Privately Owned Public Space</li> <li>• Product Design / Development</li> <li>• Refuse Chute Chamber</li> </ul>	<ul style="list-style-type: none"> <li>• Refuse Room</li> <li>• Research / Research &amp; Development</li> <li>• Residual Area and Corridor (Carpark Floor)</li> <li>• Roof Terrace</li> <li>• Stage</li> <li>• Storey Shelter</li> <li>• Swimming Pool</li> <li>• Test Laboratory</li> <li>• Vending Machine Kiosk</li> <li>• Warehouse/ Storage / Staging</li> <li>• Workrooms/ Meeting Area/ Collaboration</li> </ul>



## Modelling IFC-SG (Space – Area Requirement)

IFC Entity: IfcSpace					
IFC SubType: AREA_GFA					
	IFC-SG Property	Actual Values			
2 f	<b>AGF_Name [Text]</b>  (When <b>AGF_DevelopmentUse =            “Civic &amp; Community            Institution”</b> )	<ul style="list-style-type: none"> <li>• Airwell</li> <li>• Arts Centre</li> <li>• Association</li> <li>• ATM Kiosk</li> <li>• Balcony</li> <li>• Bicycle Parking Space</li> <li>• Bin Centre</li> <li>• Bin Point</li> <li>• Boys' / Girls' Home</li> <li>• Bunk/ Resting</li> <li>• Cable Chamber</li> <li>• Child Care Centre</li> <li>• Classroom</li> <li>• Columbarium</li> <li>• Community/ Social Uses</li> <li>• Control Room/ Centre</li> <li>• Court/ Pitch/ Field</li> <li>• Courtroom</li> <li>• Courtyard</li> <li>• Cultural Centre / Heritage Centre</li> </ul>	<ul style="list-style-type: none"> <li>• Discharge Valve Chamber</li> <li>• Driveways</li> <li>• Educational / Training Institutions</li> <li>• Elderly Day-Care Centre</li> <li>• Embalming Facilities</li> <li>• Embassy / Consulate / High Commission</li> <li>• Entrance Canopy</li> <li>• Equipment/ Storage</li> <li>• Evidence Room</li> <li>• Examination Room</li> <li>• Exhibit Area</li> <li>• Façade Articulation</li> <li>• Family Service Centre</li> <li>• Function Room</li> <li>• Funeral Parlour</li> <li>• Funeral-related Uses</li> <li>• Gondola and working platform</li> <li>• Government Building / Office</li> <li>• Guardhouse / Sentry Post</li> <li>• Holding Area/ Cell</li> <li>• Inmate Dayrooms</li> <li>• Interview Room</li> </ul>	<ul style="list-style-type: none"> <li>• Judge Chambers</li> <li>• Kitchen/ Pantry/ Food Preparation area</li> <li>• Letter Box Area</li> <li>• Library</li> <li>• Lift Lobby</li> <li>• Lift Motor Room</li> <li>• Loading and Unloading Bay</li> <li>• M&amp;E Floor</li> <li>• M&amp;E Room (enclosed)</li> <li>• M&amp;E Services (non-load bearing covering above)</li> <li>• M&amp;E Space (unenclosed)</li> <li>• Meditation Space</li> <li>• Meeting Room</li> <li>• Museum</li> <li>• Office</li> <li>• Outdoor Refreshment Area</li> <li>• Outdoor Refreshment Kiosk</li> <li>• Pavilion</li> <li>• Performance/ Theatre/ Auditorium</li> <li>• Pick-up/ Drop-off Point</li> <li>• Privately Owned Public Space</li> </ul>	<ul style="list-style-type: none"> <li>• Refuse Chute Chamber</li> <li>• Refuse Room</li> <li>• Residual Area and Corridor (Carpark Floor)</li> <li>• Roof Terrace</li> <li>• Secure Visiting Room</li> <li>• Security/Control</li> <li>• Social Services Facilities</li> <li>• Stage</li> <li>• Storey Shelter</li> <li>• Student Care Centre</li> <li>• Swimming Pool</li> <li>• Vending Machine Kiosk</li> <li>• Welfare Home</li> <li>• Workers' Dormitory</li> </ul>

## Modelling IFC-SG (Space) for URA



# Modelling IFC-SG (Space – Area Requirement)

IFC Entity: IfcSpace					
IFC SubType: AREA_GFA					
	IFC-SG Property	Actual Values			
2g	<b>AGF_Name [Text]</b>  (When <b>AGF_DevelopmentUse = "Commercial"</b> )	<ul style="list-style-type: none"> <li>Airwell</li> <li>Amusement Centre</li> <li>ATM Kiosk</li> <li>Auto Accessories/Tyre &amp; Battery Shop</li> <li>Balcony</li> <li>Bank</li> <li>Bar/Pub</li> <li>Beauty Salon</li> <li>Betting Centre</li> <li>Bicycle Parking Space</li> <li>Bin Centre</li> <li>Bin Point</li> <li>Cable Chamber</li> <li>Car Parking Lot (Mechanised)</li> <li>Car Polishing &amp; Waxing</li> <li>Cinema</li> <li>Coffin Shop</li> <li>Commercial School</li> <li>Control Room/ Centre</li> <li>Convention Centre / Exhibition</li> <li>Court/ Pitch/ Field</li> <li>Courtyard</li> <li>Discharge Valve Chamber</li> <li>Driveways</li> <li>End of Trip Facilities</li> <li>Entrance Canopy</li> <li>Equipment/ Storage</li> </ul>	<ul style="list-style-type: none"> <li>Façade Articulation</li> <li>Foot Reflexology</li> <li>Function Room</li> <li>Gondola and working platform</li> <li>Guardhouse / Sentry Post</li> <li>Gym/Fitness Centre</li> <li>Hawker/Food Centre/Canteen</li> <li>Karaoke Lounge</li> <li>Kiosk (Retail)</li> <li>Kitchen/ Pantry/ Food Preparation area/ Food Stall</li> <li>Laundromat</li> <li>Letter Box Area</li> <li>Lift Lobby</li> <li>Lift Motor Room</li> <li>Loading and Unloading Bay</li> <li>Loft</li> <li>M&amp;E Floor</li> <li>M&amp;E Room (enclosed)</li> <li>M&amp;E Services (non-load bearing covering above)</li> <li>M&amp;E Space (unenclosed)</li> <li>Market</li> <li>Massage Establishment</li> <li>Medical Clinic</li> <li>Medical Clinic/ Suites</li> </ul>	<ul style="list-style-type: none"> <li>Meditation Centre</li> <li>Meeting Room</li> <li>Minimart</li> <li>Nightclub</li> <li>Office</li> <li>On-Site Food Waste Treatment Area</li> <li>Outdoor Refreshment Area</li> <li>Outdoor Refreshment Kiosk</li> <li>Pavilion</li> <li>Pet Boarding/Pet Day Care</li> <li>Pet Shop/Pet Grooming</li> <li>Petrol Station</li> <li>Pick-up/ Drop-off Point</li> <li>Private Commercial Foreign System School</li> <li>Privately Owned Public Space</li> <li>Refuse Chute Chamber</li> <li>Refuse Room</li> <li>Residual Area and Corridor (Carpark Floor)</li> <li>Restaurant</li> <li>Restaurant and bar</li> </ul>	<ul style="list-style-type: none"> <li>Restaurant and bar with live entertainment</li> <li>Restaurant with live entertainment</li> <li>Roof Terrace</li> <li>Shop</li> <li>Showroom</li> <li>Stage</li> <li>Storey Shelter</li> <li>Supermarket</li> <li>Swimming Pool</li> <li>Takeaway Food Shop</li> <li>Traditional Chinese Medicine</li> <li>Vending Machine Kiosk</li> <li>Vet Clinic/ Animal Hospital</li> <li>Visitor Centre</li> <li>Wholesale and Distribution Centre</li> <li>Work Booth</li> </ul>

## Modelling IFC-SG (Space) for URA



## Modelling IFC-SG (Space – Area Requirement)

IFC Entity: IfcSpace					
IFC SubType: AREA_GFA					
	IFC-SG Property	Actual Values			
2 h	<b>AGF_Name [Text]</b>  (When <b>AGF_DevelopmentUse =            “Educational Institution”</b> )	<ul style="list-style-type: none"> <li>Airwell</li> <li>Balcony</li> <li>Bicycle Parking Space</li> <li>Bin Centre</li> <li>Bin Point</li> <li>Cable Chamber</li> <li>Classroom</li> <li>Computer room</li> <li>Control Room/ Centre</li> <li>Court/ Pitch/ Field</li> <li>Courtyard</li> <li>Discharge Valve Chamber</li> <li>Driveways</li> <li>End of Trip Facilities</li> </ul>	<ul style="list-style-type: none"> <li>Entrance Canopy</li> <li>Equipment/ Storage</li> <li>Façade Articulation</li> <li>Gondola and working platform</li> <li>Guardhouse / Sentry Post</li> <li>Home Economics/ Cooking</li> <li>Kindergarten</li> <li>Laboratory</li> <li>Lecture Theatre</li> <li>Leisure Room</li> <li>Letter Box Area</li> <li>Lift Lobby</li> <li>Lift Motor Room</li> <li>Loading and Unloading Bay</li> </ul>	<ul style="list-style-type: none"> <li>M&amp;E Room (enclosed)</li> <li>M&amp;E Services (non-load bearing covering above)</li> <li>M&amp;E Space (unenclosed)</li> <li>Multipurpose Hall/ Sports Hall</li> <li>Music room</li> <li>Pavilion</li> <li>Pick-up/ Drop-off Point</li> <li>Privately Owned Public Space</li> <li>Refuse Chute Chamber</li> <li>Refuse Room</li> <li>Religious Facilities</li> <li>Residual Area and Corridor (Carpark Floor)</li> <li>Roof Terrace</li> </ul>	<ul style="list-style-type: none"> <li>School Canteen</li> <li>School Gym</li> <li>School Library</li> <li>Special Needs</li> <li>Stage</li> <li>Storey Shelter</li> <li>Students' Hostel</li> <li>Studio</li> <li>Study Area</li> <li>Swimming Pool</li> <li>Teachers / Staff room</li> <li>Vending Machine Kiosk</li> <li>Workshop</li> </ul>
2 i	<b>AGF_Name [Text]</b>  (When <b>AGF_DevelopmentUse =            “Health &amp; Medical Care”</b> )	<ul style="list-style-type: none"> <li>Airwell</li> <li>ATM Kiosk</li> <li>Balcony</li> <li>Bicycle Parking Space</li> <li>Bin Centre</li> <li>Bin Point</li> <li>Cable Chamber</li> <li>Car Parking Lot (Mechanised)</li> <li>Consulting rooms</li> <li>Control Room/ Centre</li> <li>Courtyard</li> <li>Discharge Valve Chamber</li> <li>Driveways</li> <li>End of Trip Facilities</li> <li>Entrance Canopy</li> </ul>	<ul style="list-style-type: none"> <li>Equipment/ Storage</li> <li>Façade Articulation</li> <li>First aid rooms</li> <li>Function Room</li> <li>Gondola and working platform</li> <li>Guardhouse / Sentry Post</li> <li>Hospice</li> <li>Intensive care units</li> <li>Isolation units</li> <li>Kitchen/ Pantry/ Food Preparation area</li> <li>Letter Box Area</li> <li>Lift Lobby</li> <li>Lift Motor Room</li> <li>Loading and Unloading Bay</li> <li>Lounge</li> <li>M&amp;E Floor</li> <li>M&amp;E Room (enclosed)</li> </ul>	<ul style="list-style-type: none"> <li>M&amp;E Services (non-load bearing covering above)</li> <li>M&amp;E Space (unenclosed)</li> <li>Medical Clinic/ Suites</li> <li>Medical scanning and x-ray rooms</li> <li>Medical treatment rooms</li> <li>Meeting Room</li> <li>Nursing Home</li> <li>Occupational therapy rooms</li> <li>Office</li> <li>Operating theatres</li> <li>Outdoor Refreshment Area</li> <li>Outdoor Refreshment Kiosk</li> <li>Pavilion</li> <li>Pharmacy</li> <li>Phototherapy</li> <li>Physiotherapy</li> </ul>	<ul style="list-style-type: none"> <li>Pick-up/ Drop-off Point</li> <li>Privately Owned Public Space</li> <li>Refuse Chute Chamber</li> <li>Refuse Room</li> <li>Rehabilitation rooms</li> <li>Residual Area and Corridor (Carpark Floor)</li> <li>Roof Terrace</li> <li>Staff Quarters</li> <li>Stage</li> <li>Storey Shelter</li> <li>Swimming Pool</li> <li>Vending Machine Kiosk</li> <li>Wards</li> </ul>

## Modelling IFC-SG (Space) for URA



## Modelling IFC-SG (Space – Area Requirement)

IFC Entity: IfcSpace					
IFC SubType: AREA_GFA					
	IFC-SG Property	Actual Values			
2 j	<b>AGF_Name [Text]</b>  (When <b>AGF_DevelopmentUse =            “Hotel”</b> )	<ul style="list-style-type: none"> <li>Airwell</li> <li>ATM Kiosk</li> <li>Audio Visual Room</li> <li>Back of House</li> <li>Backpackers' Hostel</li> <li>Balcony</li> <li>Banquet Hall/ Ballroom</li> <li>Bicycle Parking Space</li> <li>Bin Centre</li> <li>Bin Point</li> <li>Cable Chamber</li> <li>Car Parking Lot (Mechanised)</li> <li>Clubhouse</li> <li>Conserved Bungalow</li> </ul>	<ul style="list-style-type: none"> <li>Control Room/ Centre</li> <li>Courtyard</li> <li>Discharge Valve Chamber</li> <li>Driveways</li> <li>End of Trip Facilities</li> <li>Entrance Canopy</li> <li>Equipment/ Storage</li> <li>Façade Articulation</li> <li>Function Room</li> <li>Gondola and working platform</li> <li>Guardhouse / Sentry Post</li> <li>Guest Room/ Hotel Room</li> <li>Gym/Fitness Centre (for Hotel guests only)</li> </ul>	<ul style="list-style-type: none"> <li>Kitchen/ Food Preparation area</li> <li>Letter Box Area</li> <li>Lift Lobby</li> <li>Lift Motor Room</li> <li>Loading and Unloading Bay</li> <li>Lounge</li> <li>M&amp;E Floor</li> <li>M&amp;E Room (enclosed)</li> <li>M&amp;E Services (non-load bearing covering above)</li> <li>M&amp;E Space (unenclosed)</li> <li>Meeting/ Board/ Conference Room</li> <li>Outdoor Refreshment Area</li> <li>Outdoor Refreshment Kiosk</li> <li>Pavilion</li> <li>Pick-up/ Drop-off Point</li> </ul>	<ul style="list-style-type: none"> <li>Privately Owned Public Space</li> <li>Reflexology/ Massage (for Hotel guests only)</li> <li>Refuse Chute Chamber</li> <li>Refuse Room</li> <li>Residual Area and Corridor (Carpark Floor)</li> <li>Roof Terrace</li> <li>Staff Quarters</li> <li>Stage</li> <li>Storey Shelter</li> <li>Swimming Pool</li> <li>Vending Machine Kiosk</li> </ul>
2 k	<b>AGF_Name [Text]</b>  (When <b>AGF_DevelopmentUse =            “Place of Worship”</b> )	<ul style="list-style-type: none"> <li>Airwell</li> <li>ATM Kiosk</li> <li>Balcony</li> <li>Bicycle Parking Space</li> <li>Bin Centre</li> <li>Bin Point</li> <li>Cable Chamber</li> <li>Chapel</li> <li>Columbarium</li> <li>Control Room/ Centre</li> <li>Courtyard</li> <li>Cultural</li> <li>Discharge Valve Chamber</li> </ul>	<ul style="list-style-type: none"> <li>Driveways</li> <li>End of Trip Facilities</li> <li>Entrance Canopy</li> <li>Equipment/ Storage</li> <li>Function Room</li> <li>Gondola and working platform</li> <li>Guardhouse / Sentry Post</li> <li>Kitchen/ Pantry/ Food Preparation area</li> <li>Letter Box Area</li> <li>Library</li> <li>Lift Lobby</li> <li>Lift Motor Room</li> </ul>	<ul style="list-style-type: none"> <li>Loading and Unloading Bay</li> <li>M&amp;E Floor</li> <li>M&amp;E Room (enclosed)</li> <li>M&amp;E Services (non-load bearing covering above)</li> <li>M&amp;E Space (unenclosed)</li> <li>Meeting Room</li> <li>Non-religious Use</li> <li>Office</li> <li>Pavilion</li> <li>Pick-up/ Drop-off Point</li> <li>Praying Area</li> <li>Quarters</li> <li>Refuse Chute Chamber</li> <li>Refuse Room</li> <li>Religious School</li> </ul>	<ul style="list-style-type: none"> <li>Religious Teachings</li> <li>Religious Use</li> <li>Residual Area and Corridor (Carpark Floor)</li> <li>Roof Terrace</li> <li>Shrine</li> <li>Stage</li> <li>Storey Shelter</li> <li>Swimming Pool</li> <li>Theatre/ Auditorium</li> <li>Vending Machine Kiosk</li> </ul>

## Modelling IFC-SG (Space) for URA



## Modelling IFC-SG (Space – Area Requirement)

IFC Entity: IfcSpace					
IFC SubType: AREA_GFA					
	IFC-SG Property	Actual Values			
2 l	<b>AGF_Name [Text]</b>  (When <b>AGF_DevelopmentUse =</b> <b>“Rapid Transit”</b> )	<ul style="list-style-type: none"> <li>Airwell</li> <li>ATM Kiosk</li> <li>Bicycle Parking Space</li> <li>Bin Centre</li> <li>Bin Point</li> <li>Cable Chamber</li> <li>Cleaning Area</li> <li>Control Room/ Centre</li> <li>Courtyard</li> </ul>	<ul style="list-style-type: none"> <li>Discharge Valve Chamber</li> <li>Driveways</li> <li>End of Trip Facilities</li> <li>Entrance Canopy</li> <li>Equipment/ Storage platform</li> <li>Inspection</li> <li>Letter Box Area</li> <li>Lift Lobby</li> <li>Lift Motor Room</li> </ul>	<ul style="list-style-type: none"> <li>Loading and Unloading Bay</li> <li>M&amp;E Floor</li> <li>M&amp;E Room (enclosed)</li> <li>M&amp;E Space (unenclosed)</li> <li>Office</li> <li>Pick-up/ Drop-off Point</li> <li>Platform Area</li> <li>Privately Owned Public Space</li> <li>Refuse Chute Chamber</li> <li>Refuse Room</li> </ul>	<ul style="list-style-type: none"> <li>Residual Area and Corridor (Carpark Floor)</li> <li>Roof Terrace</li> <li>Station Control</li> <li>Storey Shelter</li> <li>Vending Machine Kiosk</li> </ul>
2 m	<b>AGF_Name [Text]</b>  (When <b>AGF_DevelopmentUse =</b> <b>“Sports &amp; Recreation”</b> )	<ul style="list-style-type: none"> <li>Airwell</li> <li>ATM Kiosk</li> <li>Audio Visual Room</li> <li>Back of House</li> <li>Balcony</li> <li>Bicycle Parking Space</li> <li>Bin Centre</li> <li>Bin Point</li> <li>Cable Chamber</li> <li>Chalet / Bungalow</li> <li>Clubhouse</li> <li>Control Room/ Centre</li> <li>Court/ Pitch/ Field</li> <li>Courtyard</li> <li>Discharge Valve Chamber</li> </ul>	<ul style="list-style-type: none"> <li>Dressroom</li> <li>Driveways</li> <li>Entrance Canopy</li> <li>Equipment/ Storage</li> <li>Exhibition Room</li> <li>Function Room</li> <li>Guardhouse / Sentry Post</li> <li>Gym/Fitness Centre</li> <li>Letter Box Area</li> <li>Lift Lobby</li> <li>Lift Motor Room</li> <li>Loading and Unloading Bay</li> <li>Lounge</li> <li>M&amp;E Floor</li> </ul>	<ul style="list-style-type: none"> <li>M&amp;E Room (enclosed)</li> <li>M&amp;E Services (non-load bearing covering above)</li> <li>M&amp;E Space (unenclosed)</li> <li>Meeting Room</li> <li>Multipurpose Hall/ Sports Hall</li> <li>Office</li> <li>Outdoor Refreshment Area</li> <li>Outdoor Refreshment Kiosk</li> <li>Pavilion</li> <li>Pick-up/ Drop-off Point</li> <li>Privately Owned Public Space</li> <li>Recreational Club</li> <li>Refuse Chute Chamber</li> </ul>	<ul style="list-style-type: none"> <li>Refuse Room</li> <li>Residual Area and Corridor (Carpark Floor)</li> <li>Roof Terrace</li> <li>Security / Control</li> <li>Stage</li> <li>Storey Shelter</li> <li>Studio</li> <li>Swimming Pool</li> <li>Theatre/ Auditorium</li> <li>Theme Park</li> <li>Vending Machine Kiosk</li> <li>Viewing Gallery</li> </ul>



## Modelling IFC-SG (Space) for URA



## Modelling IFC-SG (Space – Area Requirement)

IFC Entity: IfcSpace					
IFC SubType: AREA_GFA					
	IFC-SG Property	Actual Values			
2 n	<b>AGF_Name [Text]</b>  (When <b>AGF_DevelopmentUse =</b> <b>“Transport Facilities”</b> )	<ul style="list-style-type: none"> <li>Airwell</li> <li>ATM Kiosk</li> <li>Bicycle Parking Space</li> <li>Bin Centre</li> <li>Bin Point</li> <li>Cable Chamber</li> <li>Cleaning Area</li> <li>Control Room/ Centre</li> <li>Courtyard</li> <li>Depot</li> </ul>	<ul style="list-style-type: none"> <li>Discharge Valve Chamber</li> <li>Driveways</li> <li>Entrance Canopy</li> <li>Equipment Storage</li> <li>Fuelling Space</li> <li>Gondola and working platform</li> <li>Letter Box Area</li> <li>Lift Lobby</li> </ul>	<ul style="list-style-type: none"> <li>Lift Motor Room</li> <li>Loading and Unloading Bay</li> <li>M&amp;E Floor</li> <li>M&amp;E Room (enclosed)</li> <li>M&amp;E Space (unenclosed)</li> <li>Motorcycle Parking Lot</li> <li>Office</li> <li>Pick-up/ Drop-off Point</li> <li>Refuse Chute Chamber</li> <li>Refuse Room</li> <li>Repair Yard</li> </ul>	<ul style="list-style-type: none"> <li>Residual Area and Corridor (Carpark Floor)</li> <li>Roof Terrace</li> <li>Servicing and Testing</li> <li>Standing space (Vehicular)</li> <li>Storey Shelter</li> <li>Vending Machine Kiosk</li> </ul>
2 o	<b>AGF_Name [Text]</b>  (When <b>AGF_DevelopmentUse =</b> <b>“Utility”</b> )	<ul style="list-style-type: none"> <li>Airwell</li> <li>ATM Kiosk</li> <li>Bicycle Parking Space</li> <li>Bin Centre</li> <li>Bin Point</li> <li>Cable Chamber</li> <li>Control Room/ Centre</li> <li>Courtyard</li> <li>Discharge Valve Chamber</li> </ul>	<ul style="list-style-type: none"> <li>Driveways</li> <li>End of Trip Facilities</li> <li>Entrance Canopy</li> <li>Gondola and working platform</li> <li>Letter Box Area</li> <li>Lift Lobby</li> <li>Lift Motor Room</li> <li>Loading and Unloading Bay</li> </ul>	<ul style="list-style-type: none"> <li>M&amp;E Floor</li> <li>M&amp;E Room (enclosed)</li> <li>M&amp;E Space (unenclosed)</li> <li>Motorcycle Parking Lot</li> <li>Office</li> <li>Pick-up/ Drop-off Point</li> <li>Privately Owned Public Space</li> <li>Receiving/ Transmitting</li> <li>Refuse Chute Chamber</li> <li>Refuse Room</li> </ul>	<ul style="list-style-type: none"> <li>Residual Area and Corridor (Carpark Floor)</li> <li>Roof Terrace</li> <li>Storey Shelter</li> <li>Treatment Area</li> <li>Vending Machine Kiosk</li> <li>Voltage/ Transformer</li> </ul>

## Modelling IFC-SG (Space) for URA



# Modelling IFC-SG (Space – Area Requirement)

IFC Entity: IfcSpace					
IFC SubType: AREA_GFA					
	IFC-SG Property	Actual Values / Example			
3	AGF_UnitNumber [Text]	<ul style="list-style-type: none"> <li>B3-01a (Example)</li> <li>B2M-120D (Example)</li> <li>B1M-05A (Example)</li> </ul>		<ul style="list-style-type: none"> <li>01-03A (Example)</li> <li>01-03b (Example)</li> <li>10-04ab (Example)</li> </ul>	
4	AGF_BonusGFAType [Text]	<ul style="list-style-type: none"> <li>Balcony Incentive Scheme</li> <li>Conserved Bungalows Scheme</li> </ul>	<ul style="list-style-type: none"> <li>Indoor Recreation Spaces Scheme</li> <li>Built Environment Transformation Scheme</li> <li>Community and Sports Facilities Scheme</li> </ul>	<ul style="list-style-type: none"> <li>Rooftop ORA on Landscaped Roofs</li> <li>ORA within Privately-Owned Public Spaces (POPS)</li> <li>CBD Incentive Scheme</li> </ul>	<ul style="list-style-type: none"> <li>Strategic Development Incentive (SDI) Scheme</li> <li>Facade Articulation Scheme</li> </ul>
5	AGF_Note [Text]	Accompanying notes for QP to elaborate on use and purpose of spaces. If "Others" have been entered under AVF_Name, to fill in actual use of the area /space.			
6	AGF_UseQuantum [Text]	<ul style="list-style-type: none"> <li>Predominant</li> <li>Ancillary</li> </ul>			
7	AGF_BuildingTypology [Text]	<ul style="list-style-type: none"> <li>Flats</li> <li>Condominium</li> <li>Shophouse</li> <li>Terrace House</li> </ul>	<ul style="list-style-type: none"> <li>Detached House</li> <li>Semi-Detached House</li> <li>Good Class Bungalow</li> <li>Strata-Landed</li> </ul>	<ul style="list-style-type: none"> <li>Housing</li> <li>Serviced Apartments</li> </ul>	<ul style="list-style-type: none"> <li>Light Industry</li> <li>Clean Industry</li> <li>General Industry</li> <li>Special Industry</li> </ul>
8	AGF_SupportingFacility [Text]	<ul style="list-style-type: none"> <li>Electrical Substation</li> </ul>	<ul style="list-style-type: none"> <li>Vehicular Parking Area</li> </ul>		



## Modelling IFC-SG (Space – Area Requirement)

IFC Entity: IfcSpace		
IFC SubType: AREA_STRATA		
	IFC-SG Property	Actual Values / Example
1	AST_AreaType [Text]	<ul style="list-style-type: none"> <li>• Strata (Private)</li> <li>• Strata (Communal)</li> <li>• Common Area</li> </ul>
2	AST_LegalArea [Number]	<ul style="list-style-type: none"> <li>• 101.01 (Example)</li> <li>• 99.23 (Example)</li> </ul>
3	AST_Prop_StrataLotNumber [Text]	<ul style="list-style-type: none"> <li>• MK02-U017049L (Example)</li> </ul>
4	AST_Extg_StrataLotNumber [Text]	<ul style="list-style-type: none"> <li>• MK02-U017646Z (Example)</li> </ul>

IFC Entity: IfcSpace		
IFC SubType: AREA_CONNECTIVITY		
	IFC-SG Property	Actual Values / Example
1	ACN_ConnectivityType [Text]	<ul style="list-style-type: none"> <li>• Open Walkway</li> <li>• Covered Walkway</li> <li>• Covered Linkway</li> <li>• Through Block Link</li> <li>• Elevated Pedestrian Link</li> <li>• Underground Pedestrian Link</li> <li>• Sky Bridge</li> <li>• Public Space Node</li> <li>• Cycling Path</li> </ul>
2	ACN_ActivityGeneratingUseType [Text]	<ul style="list-style-type: none"> <li>• Single Side</li> <li>• Double Side</li> </ul>
3	ACN_IsPavingSpecified [Boolean]	<ul style="list-style-type: none"> <li>• Yes/No</li> </ul>
4	ACN_PavingSpecification [Text]	<ul style="list-style-type: none"> <li>• &lt;UDAREA&gt; PavingSpecification* (Example)</li> </ul>
5	ACN_IsOpen24HoursToPublic [Boolean]	<ul style="list-style-type: none"> <li>• Yes/No</li> </ul>
6	ACN_OpenTime [Text]	<ul style="list-style-type: none"> <li>• 23:59:59 (Example)</li> </ul>
7	ACN_CloseTime [Text]	<ul style="list-style-type: none"> <li>• 23:59:59 (Example)</li> </ul>



## Modelling IFC-SG (Space – Area Requirement)

IFC Entity: IfcSpace			
IFC SubType: AREA_LANDSCAPE			
	IFC-SG Property	Actual Values / Example	
1	ALS_LandscapeType [Text]	<ul style="list-style-type: none"> <li>• Turfing</li> <li>• Groundcovers</li> <li>• Shrubs</li> <li>• Decked/ Patterned Floor</li> </ul>	<ul style="list-style-type: none"> <li>• Water Feature</li> <li>• Landscaped Footpath</li> <li>• Playground</li> <li>• BBQ Pit</li> </ul>
2	ALS_GreeneryFeatures [Text]	<ul style="list-style-type: none"> <li>• Green Buffer</li> <li>• Peripheral Planting Strip</li> <li>• Landscape Deck - Vertical Greenery</li> <li>• Landscape Deck - Surface Greenery</li> <li>• Communal Ground Garden</li> <li>• Sky Terrace</li> </ul>	<ul style="list-style-type: none"> <li>• Roof Top Landscaping</li> <li>• Ground Landscaping</li> <li>• Urban Farm / Greenhouse</li> <li>• Vertical Greenery</li> <li>• Extensive Green Roof</li> <li>• Green Verge</li> </ul>
3	ALS_Species [Text]	<ul style="list-style-type: none"> <li>• *Ophiopogon jaburan (Example)</li> <li>• *Codiaeum variegatum (Example)</li> <li>• *Dracaena marginata (Example)</li> <li>• *Murraya paniculata (Example)</li> </ul>	

IFC Entity: IfcSpace			
IFC SubType: AREA_VERIFICATION			
	IFC-SG Property	Actual Values	
1	AVF_IncludeAsGFA [Boolean]	<ul style="list-style-type: none"> <li>• Yes/No</li> </ul>	



## Modelling IFC-SG (Space Usage)

Spaces across BCA, LTA, NEA, PUB and SCDF have been harmonized and standardized for checks into **Occupancy Types** and **Space Name** categories. All of these spaces are based on the IFC Entity “IfcSpace” and do not require any IfcSubType. Every space component should include inputs for **both Occupancy Type and Space Name parameters**. Some space components may require additional parameters listed at [here](#).

### ► Occupancy Types

#### Small Residential

- 1) Single dwelling residential

#### Other Residential

- 2) Multi-unit residential

#### Institutional

- 3) Supervisory care facility
- 4) Supervisory care facility (detention)
- 5) Nursing care facilities
- 6) Hospital with A&E services
- 7) Hospital without A&E services
- 8) Ambulatory care facility
- 9) Ambulatory care facility (standalone)
- 10) Custodian care facility
- 11) Custodian care facility (nursery)
- 12) Public education institution
- 13) Private education institution
- 14) Worker dormitory

#### Office

- 15) Office
- 16) Telephone exchange/ central office
- 17) Factory office

#### Shop

- 18) shop
- 19) Outdoor Display Area (ODA)
- 20) Outpatient clinic
- 21) Polyclinic
- 22) Market
- 23) Temporary showflat
- 24) Factory showroom

#### Factory

- 25) Petrol station
- 26) Factory
- 27) Food production factory
- 28) M&E area
- 29) Wafer fabrication plant
- 30) Trade effluent treatment plant
- 31) Waste management and recycling
- 32) Embalming facility
- 33) Agriculture
- 34) Animal related facility
- 35) High containment facility
- 36) Electrical and gas facility

#### Place of Public Resort

- 37) Body treatment place
- 38) Entertainment place
- 39) Assembly place
- 40) Cinema
- 41) Recreational place
- 42) Sky terrace
- 43) F&B outlet
- 44) Fast food outlet
- 45) Outdoor Refreshment Area (ORA)
- 46) Food centre
- 47) Educational place
- 48) Serviced apartment
- 49) Hostel
- 50) Hotel
- 51) Backpacker hotel
- 52) Capsule hotel
- 53) Community club
- 54) Social club
- 55) Religious place
- 56) Park
- 57) Sports facility

- 58) Sports facility (ancillary)
- 59) Residential amenities
- 60) Train station
- 61) Air transport terminal
- 62) Sea transport terminal
- 63) Land transport terminal

#### Storage

- 64) Rail depot
- 65) Bus depot
- 66) Parking
- 67) Fully Automated Mechanized Car Park Buildings (FAMCP)
- 68) Warehouse
- 69) Chemical/ hazmat storage
- 70) Storage

#### Others

- 71) Airbase
- 72) Live firing area
- 73) Training area
- 74) Campsite
- 75) Wet play field
- 76) Reservoir
- 77) River
- 78) Canal
- 79) Major drain
- 80) Pond
- 81) Lake
- 82) Other waterbody
- 83) Nature reserve
- 84) Nature area
- 85) School field
- 86) Promenade
- 87) Quarry
- 88) Marina



## Modelling IFC-SG (Space Usage)

### Occupancy Type for Small Residential Spaces

#### ► 1) Single dwelling residential

Applicable for a bungalow, detached house, semi-detached house, or terrace house:

SCDF		BCA		PUB	NEA
Table 1.4A Purpose Group		Table 2.2A Type of Occupancy		Accessibility Code Table 1 Building Type	Sewerage and Sanitary Works (SSW)
I	Small residential	Detached, semi-detached, terrace house, including townhouse		E Exempted	- Residential

### Occupancy Type for Other Residential Spaces

#### ► 2) Multi-unit residential

Applicable for an apartment, condominium, flat, maisonette, or studio apartment:

SCDF		BCA		PUB	NEA
Table 1.4A Purpose Group		Table 2.2A Type of Occupancy		Accessibility Code Table 1 Building Type	Sewerage and Sanitary Works (SSW)
II	Other residential	Block of flats, maisonettes		1 Residential	Multi-story residential building Residential

### Occupancy Types for Institutional Spaces

#### ► 3) Supervisory care facility

Applicable for a detention centre, correction centre, dementia centre, psychiatric rehabilitation home, rehabilitation centre, home for the spastic, children's home, home for the intellectually disabled, pre/post-natal care centre, welfare home, orphanage, voluntary children home, boys'/ girls' home, adult disability home, sheltered home or assisted living facility:

SCDF		BCA		PUB	NEA
Table 1.4A Purpose Group		Table 2.2A Type of Occupancy		Accessibility Code Table 1 Building Type	Sewerage and Sanitary Works (SSW)
III	Institutional (supervisory care facility)	Healthcare facility (inpatient)		15 Hospitals, healthcare centres, clinics, nursing homes, homes for the aged and welfare homes	- Hospitals, healthcare centres, clinics, nursing homes, homes for the aged and welfare homes

#### ► 4) Supervisory care facility (detention)

Applicable for a prison holding area or police station holding area (with overnight stay):

SCDF		BCA		PUB	NEA
Table 1.4A Purpose Group		Table 2.2A Type of Occupancy		Accessibility Code Table 1 Building Type	Sewerage and Sanitary Works (SSW)
III	Institutional (supervisory care facility)	Healthcare facility (inpatient)		17 Worker Dormitories	- Special use



## Modelling IFC-SG (Space Usage)

### (Continued) Occupancy Type for Institutional Spaces

#### ► 5) Nursing care facilities

Applicable for a convalescent home, home for the aged, hospice or nursing home:

SCDF		BCA		PUB	NEA	
Table 1.4A Purpose Group	Table 2.2A Type of Occupancy	Accessibility Code Table 1 Building Type		Sewerage and Sanitary Works (SSW)		
III	Institutional (nursing care facility)	Healthcare facility (inpatient)	15	Hospitals, healthcare centres, clinics, nursing homes, homes for the aged and welfare homes	-	Hospitals, healthcare centres, clinics, nursing homes, homes for the aged and welfare homes

#### ► 6) Hospital with A&E services

#### ► 7) Hospital without A&E services

Applicable for a public hospital, private hospital, community hospital or psychiatric hospital:

SCDF		BCA		PUB	NEA	
Table 1.4A Purpose Group	Table 2.2A Type of Occupancy	Accessibility Code Table 1 Building Type		Sewerage and Sanitary Works (SSW)		
III	Institutional (hospital facility)	Healthcare facility (inpatient)	15	Hospitals, healthcare centres, clinics, nursing homes, homes for the aged and welfare homes	Hospital, medical clinic, centre	Hospitals, healthcare centres, clinics, nursing homes, homes for the aged and welfare homes

#### ► 8) Ambulatory care facility

Applicable for an aesthetic clinic, endoscopy clinic, non-mental rehabilitation day centre or renal dialysis day centre located within a complex:

SCDF		BCA		PUB	NEA	
Table 1.4A Purpose Group	Table 2.2A Type of Occupancy	Accessibility Code Table 1 Building Type		Sewerage and Sanitary Works (SSW)		
III	Institutional (ambulatory care facility)	Healthcare facility (outpatient)	4	Shopping complexes and multi-purpose complexes	-	Hospitals, healthcare centres, clinics, nursing homes, homes for the aged and welfare homes

#### ► 9) Ambulatory care facility (standalone)

Applicable for a standalone building consisting of mainly ambulatory care facilities:

SCDF		BCA		PUB	NEA	
Table 1.4A Purpose Group	Table 2.2A Type of Occupancy	Accessibility Code Table 1 Building Type		Sewerage and Sanitary Works (SSW)		
III	Institutional (ambulatory care facility)	Healthcare facility (inpatient)	15	Hospitals, healthcare centres, clinics, nursing homes, homes for the aged and welfare homes	-	Hospitals, healthcare centres, clinics, nursing homes, homes for the aged and welfare homes



## Modelling IFC-SG (Space Usage)

### (Continued) Occupancy Type for Institutional Spaces

#### ► 10) Custodian care facility

Applicable for a mental rehabilitation day care centre, daycare centre, mentally/ intellectually disabled day care centre, senior activity centre, senior care centre, school for the spastic or psychiatric day care centre:

SCDF		BCA		PUB	NEA	
Table 1.4A Purpose Group		Table 2.2A Type of Occupancy		Accessibility Code Table 1 Building Type	Sewerage and Sanitary Works (SSW)	
III	Institutional (custodian care facility)	Healthcare facility (outpatient)	15	Hospitals, healthcare centres, clinics, nursing homes, homes for the aged and welfare homes	-	Hospitals, healthcare centres, clinics, nursing homes, homes for the aged and welfare homes

#### ► 11) Custodian care facility (nursery)

Applicable for a childcare day centre, infant-care day centre or kindergarten for children under 6 years of age:

SCDF		BCA		PUB	NEA	
Table 1.4A Purpose Group		Table 2.2A Type of Occupancy		Accessibility Code Table 1 Building Type	Sewerage and Sanitary Works (SSW)	
III	Institutional (custodian care facility)	Healthcare facility (outpatient)	13	Pre-schools, schools, colleges, universities and institutions of learning	Commercial (childcare)	Educational / institution

#### ► 12) Public education institution

Applicable for a public school, training institution or test centre:

SCDF		BCA		PUB	NEA	
Table 1.4A Purpose Group		Table 2.2A Type of Occupancy		Accessibility Code Table 1 Building Type	Sewerage and Sanitary Works (SSW)	
III	Institutional (education / training)	Schools and educational buildings	13	Pre-schools, schools, colleges, universities and institutions of learning	-	Educational / institution

#### ► 13) Private education institution

Applicable for a tuition centre, enrichment centre, private school, commercial school or training institution:

SCDF		BCA		PUB	NEA	
Table 1.4A Purpose Group		Table 2.2A Type of Occupancy		Accessibility Code Table 1 Building Type	Sewerage and Sanitary Works (SSW)	
III	Institutional (education / training)	Schools and educational buildings	13	Pre-schools, schools, colleges, universities and institutions of learning	Commercial (tuition centre)	Educational / institution

#### ► 14) Worker dormitory

SCDF		BCA		PUB	NEA	
Table 1.4A Purpose Group		Table 2.2A Type of Occupancy		Accessibility Code Table 1 Building Type	Sewerage and Sanitary Works (SSW)	
III	Institutional (worker lodging)	Hotels, boarding houses, serviced apartments, hostels, backpacker hotel, dormitories	17	Worker dormitories	-	Worker dormitories





## Modelling IFC-SG (Space Usage)

### Occupancy Type for Office Spaces

#### ► 15) Office

Applicable for a bank, stock broker, telephone/ telegraph operator, publisher, insurance / finance / real estate / advertising / employment / marketing agency, embassy (administrative office):

SCDF		BCA			PUB	NEA
Table 1.4A Purpose Group	Table 2.2A Type of Occupancy	Accessibility Code Table 1 Building Type			Sewerage and Sanitary Works (SSW)	
IV	Office	Offices	3	Office building	-	Office

#### ► 16) Telephone exchange/central office

Applicable for offices use for telecommunication purposes.:

SCDF		BCA			PUB	NEA
Table 1.4A Purpose Group	Table 2.2A Type of Occupancy	Accessibility Code Table 1 Building Type			Sewerage and Sanitary Works (SSW)	
IV	Office	Offices	3	Office building	-	-

#### ► 17) Factory Office

Applicable for factory, utility, or warehouse buildings only:

SCDF		BCA			PUB	NEA
Table 1.4A Purpose Group	Table 2.2A Type of Occupancy	Accessibility Code Table 1 Building Type			Sewerage and Sanitary Works (SSW)	
IV	Office	Offices	16	Factories, workshops, industrial buildings and office / showroom areas in warehouses	-	Office

### Occupancy Type for Shop Spaces

#### ► 18) Shop

Applicable for a beauty salon, hairdressing salon, book store, boutique, confectionery outlet, gift shop, jewellery shop, laundry, laundromat, pawnshop, provisional shop, ticketing agency, travel agency, drugstore, pet clinic, vet clinic, pet hospital, vet hospital, animal hospital, pet shop, pet grooming, pet boarding, pet day care, take-away food kiosk (small trade / business involving sale of goods, retail, service) or showroom not located in warehouse/ factories:

SCDF		BCA			PUB	NEA
Table 1.4A Purpose Group	Table 2.2A Type of Occupancy	Accessibility Code Table 1 Building Type			Sewerage and Sanitary Works (SSW)	
V	Shop	Shop, <b>healthcare facility (outpatient)</b>	4	Shopping complexes and multi-purpose complexes	Commercial (retail shops, dry shops)	Shop or shopping mall

#### ► 19) ODA

Applicable for outdoor display area only:

SCDF		BCA			PUB	NEA
Table 1.4A Purpose Group	Table 2.2A Type of Occupancy	Accessibility Code Table 1 Building Type			Sewerage and Sanitary Works (SSW)	
V	Shop	Shop, healthcare facility (outpatient)	4	Shopping complexes and multi-purpose complexes	-	-



## Modelling IFC-SG (Space Usage)

### (Continued) Occupancy Type for Shop Spaces

#### ► 20) Outpatient clinic

Applicable for factory, utility, or warehouse buildings only:

SCDF		BCA		PUB	NEA	
Table 1.4A Purpose Group	Table 2.2A Type of Occupancy	Accessibility Code Table 1 Building Type		Sewerage and Sanitary Works (SSW)		
V	Shop	Shop, healthcare facility (outpatient)	4	Shopping complexes and multi-purpose complexes	-	Hospitals, healthcare centres, clinics, nursing homes, homes for the aged and welfare homes

#### ► 21) Polyclinic

SCDF		BCA		PUB	NEA	
Table 1.4A Purpose Group	Table 2.2A Type of Occupancy	Accessibility Code Table 1 Building Type		Sewerage and Sanitary Works (SSW)		
V	Shop	Shop, healthcare facility (outpatient)	15	Hospitals, healthcare centres, clinics, nursing homes, homes for the aged and welfare homes	-	Hospitals, healthcare centres, clinics, nursing homes, homes for the aged and welfare homes

#### ► 22) Market

Applicable for a wet market:

SCDF		BCA		PUB	NEA	
Table 1.4A Purpose Group	Table 2.2A Type of Occupancy	Accessibility Code Table 1 Building Type		Sewerage and Sanitary Works (SSW)		
V	Shop	Shop, healthcare facility (outpatient)	11	Markets, hawker or food centres	Market	Supermarket / wet market

#### ► 23) Temporary showflat

Applicable for a standalone showflat:

SCDF		BCA		PUB	NEA	
Table 1.4A Purpose Group	Table 2.2A Type of Occupancy	Accessibility Code Table 1 Building Type		Sewerage and Sanitary Works (SSW)		
V	Shop	Shop, healthcare facility (outpatient)	E	Exempted	-	Temporary showflat

#### ► 24) Factory showroom

Applicable for factory, utility, or warehouse buildings only:

SCDF		BCA		PUB	NEA	
Table 1.4A Purpose Group	Table 2.2A Type of Occupancy	Accessibility Code Table 1 Building Type		Sewerage and Sanitary Works (SSW)		
V	Shop	Shop, healthcare facility (outpatient)	16	Factories, workshops, industrial buildings and office / showroom areas in warehouses	-	Factory showroom



## Modelling IFC-SG (Space Usage)

### Occupancy Type for Factory Spaces

#### ► 25) Petrol station

SCDF		BCA		PUB	NEA	
Table 1.4A Purpose Group	Table 2.2A Type of Occupancy	Accessibility Code Table 1 Building Type		Sewerage and Sanitary Works (SSW)		
VI	Factory	Industrial buildings (factories, workshops, godowns, warehouses)		E Exempted	-	Petrol Station

#### ► 26) Factory

Applicable for an aircraft hangar, data centre, telecommunication exchange, vehicle repair / woodwork workshop, or factory for chemicals / consumable products / fireworks / glassware / metalwork / highly combustible substances / highly flammable products / incineration / oil refinery / pharmaceutical / rubber / ship building:

SCDF		BCA		PUB	NEA	
Table 1.4A Purpose Group	Table 2.2A Type of Occupancy	Accessibility Code Table 1 Building Type		Sewerage and Sanitary Works (SSW)		
VI	Factory	Industrial buildings (factories, workshops, godowns, warehouses)	16	Factories, workshops, industrial buildings and office / showroom areas in warehouses	-	Factories, workshops, industrial buildings and office / showroom areas in warehouses

#### ► 27) Food production factory

Applicable for a central kitchen, food production facility:

SCDF		BCA		PUB	NEA	
Table 1.4A Purpose Group	Table 2.2A Type of Occupancy	Accessibility Code Table 1 Building Type		Sewerage and Sanitary Works (SSW)		
VI	Factory	Industrial buildings (factories, workshops, godowns, warehouses)	16	Factories, workshops, industrial buildings and office / showroom areas in warehouses	-	Food Production Factory

#### ► 28) M&E area

Applicable for an M&E area within a building:

SCDF		BCA		PUB	NEA	
Table 1.4A Purpose Group	Table 2.2A Type of Occupancy	Accessibility Code Table 1 Building Type		Sewerage and Sanitary Works (SSW)		
VI	Factory	Industrial buildings (factories, workshops, godowns, warehouses)	E	Exempted	-	M&E area

#### ► 29) Wafer fabrication plant

#### ► 30) Trade effluent treatment plant

Applicable for a disinfection plant:

SCDF		BCA		PUB	NEA	
Table 1.4A Purpose Group	Table 2.2A Type of Occupancy	Accessibility Code Table 1 Building Type		Sewerage and Sanitary Works (SSW)		
VI	Factory	Industrial buildings (factories, workshops, godowns, warehouses)	16	Factories, workshops, industrial buildings and office / showroom areas in warehouses	-	-



## Modelling IFC-SG (Space Usage)

### (Continued) Occupancy Type for Factory Spaces

#### ▶ 31) Waste management and recycling

#### ▶ 32) Embalming facility

SCDF			BCA		PUB	NEA
Table 1.4A Purpose Group		Table 2.2A Type of Occupancy	Accessibility Code Table 1 Building Type		Sewerage and Sanitary Works (SSW)	
VI	Factory	Industrial buildings (factories, workshops, godowns, warehouses)	16	Factories, workshops, industrial buildings and office / showroom areas in warehouses	-	-

#### ▶ 33) Agriculture

Applicable for a farm or plant nursery (no visitor area):

SCDF			BCA		PUB	NEA
Table 1.4A Purpose Group		Table 2.2A Type of Occupancy	Accessibility Code Table 1 Building Type		Sewerage and Sanitary Works (SSW)	
VI	Factory	Industrial buildings (factories, workshops, godowns, warehouses)	16	Factories, workshops, industrial buildings and office / showroom areas in warehouses	-	Agriculture

#### ▶ 34) Animal related facility

Applicable for a pet crematorium, animal shelter, quarantine facilities (no visitor area):

SCDF			BCA		PUB	NEA
Table 1.4A Purpose Group		Table 2.2A Type of Occupancy	Accessibility Code Table 1 Building Type		Sewerage and Sanitary Works (SSW)	
VI	Factory	Industrial buildings (factories, workshops, godowns, warehouses)	16	Factories, workshops, industrial buildings and office / showroom areas in warehouses	-	Animal related facility

#### ▶ 35) High containment facility

Applicable for a containment lab of biosafety level 3 and 4:

SCDF			BCA		PUB	NEA
Table 1.4A Purpose Group		Table 2.2A Type of Occupancy	Accessibility Code Table 1 Building Type		Sewerage and Sanitary Works (SSW)	
VI	Factory	Industrial buildings (factories, workshops, godowns, warehouses)	16	Factories, workshops, industrial buildings and office / showroom areas in warehouses	-	High containment facility

#### ▶ 36) Electrical and gas facility

Applicable for a power generation plant, gas transmission or receiving station:

SCDF			BCA		PUB	NEA
Table 1.4A Purpose Group		Table 2.2A Type of Occupancy	Accessibility Code Table 1 Building Type		Sewerage and Sanitary Works (SSW)	
VI	Factory	Industrial buildings (factories, workshops, godowns, warehouses)	E	Exempted	-	-



## Modelling IFC-SG (Space Usage)

### Occupancy Type for Place of Public Resort Spaces

#### ► 37) Body treatment place

Applicable for a massage establishment, foot reflexology, spa, gymnasium, fitness centre:

SCDF		BCA		PUB	NEA
Table 1.4A Purpose Group		Table 2.2A Type of Occupancy		Accessibility Code Table 1 Building Type	
Table 1.4A Purpose Group		Table 2.2A Type of Occupancy		Sewerage and Sanitary Works (SSW)	
VII	Place of public resort (body treatment)	Places of public resort and carpark	4 Shopping complexes and multi-purpose complexes	-	-

#### ► 38) Entertainment place

Applicable for an arcade, computing gaming / game machine area, karaoke lounge, night club or casino:

SCDF		BCA		PUB	NEA
Table 1.4A Purpose Group		Table 2.2A Type of Occupancy		Accessibility Code Table 1 Building Type	
Table 1.4A Purpose Group		Table 2.2A Type of Occupancy		Sewerage and Sanitary Works (SSW)	
VII	Place of public resort (entertainment)	Places of public resort and carpark	4 Shopping complexes and multi-purpose complexes	-	-

#### ► 39) Assembly place

Applicable for an auditorium, theatre or concert hall:

SCDF		BCA		PUB	NEA
Table 1.4A Purpose Group		Table 2.2A Type of Occupancy		Accessibility Code Table 1 Building Type	
Table 1.4A Purpose Group		Table 2.2A Type of Occupancy		Sewerage and Sanitary Works (SSW)	
VII	Place of public resort (entertainment)	Places of public resort and carpark	4 Shopping complexes and multi-purpose complexes	-	Conference hall, cinema, theatre, convention hall, exhibition hall

#### ► 40) Cinema

SCDF		BCA		PUB	NEA
Table 1.4A Purpose Group		Table 2.2A Type of Occupancy		Accessibility Code Table 1 Building Type	
Table 1.4A Purpose Group		Table 2.2A Type of Occupancy		Sewerage and Sanitary Works (SSW)	
VII	Place of public resort (entertainment)	Places of public resort and carpark	4 Shopping complexes and multi-purpose complexes	-	-

#### ► 41) Recreational place

Applicable for bowling / billiard / snooker / dart (leisure sport) facilities or an indoor play park:

SCDF		BCA		PUB	NEA
Table 1.4A Purpose Group		Table 2.2A Type of Occupancy		Accessibility Code Table 1 Building Type	
Table 1.4A Purpose Group		Table 2.2A Type of Occupancy		Sewerage and Sanitary Works (SSW)	
VII	Place of public resort (recreational)	Places of public resort and carpark	7 Places of public resort	-	-



## Modelling IFC-SG (Space Usage)

### (Continued) Occupancy Type for Place of Public Resort Spaces

#### ► 42) Sky terrace

Applicable for garden or terrace within a building but not on-grade, roof, or mid level, excluding those in residential units:

SCDF			BCA		PUB	NEA
Table 1.4A Purpose Group		Table 2.2A Type of Occupancy		Accessibility Code Table 1 Building Type		Sewerage and Sanitary Works (SSW)
VII	Place of public resort (recreational)	Places of public resort and carpark		D	Follow dominant use	-

#### ► 43) F&B outlet

Applicable for a pub, bar, restaurant, coffee shop or café:

#### ► 44) Fast food outlet

Applicable for a fast food outlet’s queuing and dining areas:

SCDF			BCA		PUB	NEA
Table 1.4A Purpose Group		Table 2.2A Type of Occupancy		Accessibility Code Table 1 Building Type		Sewerage and Sanitary Works (SSW)
VII	Place of public resort (F&B)	Places of public resort and carpark		10	Restaurants and eating establishments	Food establishment

#### ► 45) Outdoor Refreshment Area (ORA)

SCDF			BCA		PUB	NEA
Table 1.4A Purpose Group		Table 2.2A Type of Occupancy		Accessibility Code Table 1 Building Type		Sewerage and Sanitary Works (SSW)
VII	Place of public resort (F&B)	Places of public resort and carpark		10	Restaurants and eating establishments	-

#### ► 46) Food centre

Applicable for a food court, hawker centre or canteen:

SCDF			BCA		PUB	NEA
Table 1.4A Purpose Group		Table 2.2A Type of Occupancy		Accessibility Code Table 1 Building Type		Sewerage and Sanitary Works (SSW)
VII	Place of public resort (F&B)	Places of public resort and carpark		11	Markets, hawker or food centres	Food establishment

#### ► 47) Educational place

Applicable for a museum, exhibition centre, convention centre, art centre, gallery or library:

SCDF			BCA		PUB	NEA
Table 1.4A Purpose Group		Table 2.2A Type of Occupancy		Accessibility Code Table 1 Building Type		Sewerage and Sanitary Works (SSW)
VII	Place of public resort (educational)	Places of public resort and carpark		7	Places of public resort	-



## Modelling IFC-SG (Space Usage)

### (Continued) Occupancy Type for Place of Public Resort Spaces

#### ► 48) Serviced apartment

SCDF		BCA		PUB	NEA	
Table 1.4A Purpose Group		Table 2.2A Type of Occupancy		Accessibility Code Table 1 Building Type	Sewerage and Sanitary Works (SSW)	
VII	Place of public resort (accommodation)	Hotels, boarding houses, serviced apartments, hostels, backpacker hotels, dormitories	6	Serviced apartments	-	-

#### ► 49) Hostel

Applicable for a student hostel, visitor hostel or staff quarter:

SCDF		BCA		PUB	NEA	
Table 1.4A Purpose Group		Table 2.2A Type of Occupancy		Accessibility Code Table 1 Building Type	Sewerage and Sanitary Works (SSW)	
VII	Place of public resort (accommodation)	Hotels, boarding houses, serviced apartments, hostels, backpacker hotels, dormitories	14	Hostels, halls of residence or dormitories	-	Residential

#### ► 50) Hotel

Applicable for a hotel, resort or boarding house:

#### ► 51) Backpacker hotel

SCDF		BCA		PUB	NEA	
Table 1.4A Purpose Group		Table 2.2A Type of Occupancy		Accessibility Code Table 1 Building Type	Sewerage and Sanitary Works (SSW)	
VII	Place of public resort (accommodation)	Hotels, boarding houses, serviced apartments, hostels, backpacker hotels, dormitories	5	Hotel, boarding houses, chalets and backpacker hotels	-	-

#### ► 52) Capsule hotel

SCDF		BCA		PUB	NEA	
Table 1.4A Purpose Group		Table 2.2A Type of Occupancy		Accessibility Code Table 1 Building Type	Sewerage and Sanitary Works (SSW)	
VII	Place of public resort (accommodation)	Hotels, boarding houses, serviced apartments, hostels, backpacker hotels, dormitories	5	Hotel, boarding houses, chalets and backpacker hotels	-	-

#### ► 53) Community club

#### ► 54) Social club

Applicable for a private club or association:

SCDF		BCA		PUB	NEA	
Table 1.4A Purpose Group		Table 2.2A Type of Occupancy		Accessibility Code Table 1 Building Type	Sewerage and Sanitary Works (SSW)	
VII	Place of public resort (social)	Places of public resort and carpark	7	Places of public resort	-	-



## Modelling IFC-SG (Space Usage)

### (Continued) Occupancy Type for Place of Public Resort Spaces

#### ► 55) Religious place

Applicable for a church, mosque, temple, synagogue, funeral parlour, columbarium or crematorium visitor area:

SCDF			BCA		PUB	NEA
Table 1.4A Purpose Group		Table 2.2A Type of Occupancy	Accessibility Code Table 1 Building Type		Sewerage and Sanitary Works (SSW)	
VII	Place of public resort (religious)	Places of public resort and carpark	7	Places of public resort	-	-

#### ► 56) Park

Applicable for an on-grade park, playground, but not part of or surrounded by building(s):

SCDF			BCA		PUB	NEA
Table 1.4A Purpose Group		Table 2.2A Type of Occupancy	Accessibility Code Table 1 Building Type		Sewerage and Sanitary Works (SSW)	
-	-	-	8	Parks and open spaces including zoos, civic plazas, etc	-	-

#### ► 57) Sports facility

Applicable for a public sport complex, public swimming complex, swimming complex, stadium, indoor sports hall:

SCDF			BCA		PUB	NEA
Table 1.4A Purpose Group		Table 2.2A Type of Occupancy	Accessibility Code Table 1 Building Type		Sewerage and Sanitary Works (SSW)	
VII	Place of public resort (recreational)	Places of public resort and carpark	9	Sports complexes and public swimming pools	-	Public swimming pool / stadium

#### ► 58) Sports facility (ancillary)

Applicable for a sport facility within a school:

SCDF			BCA		PUB	NEA
Table 1.4A Purpose Group		Table 2.2A Type of Occupancy	Accessibility Code Table 1 Building Type		Sewerage and Sanitary Works (SSW)	
VII	Place of public resort (recreational)	Places of public resort and carpark	D	Follow dominant use	-	-

#### ► 59) Residential amenities

Applicable to amenities for use by residents in residential developments such as clubhouse, function room, reading room, BBQ pit, gym, swimming pool, but excluding sky terrace:

SCDF			BCA		PUB	NEA
Table 1.4A Purpose Group		Table 2.2A Type of Occupancy	Accessibility Code Table 1 Building Type		Sewerage and Sanitary Works (SSW)	
VII	Place of public resort (recreational)	Places of public resort and carpark	1	Residential	-	-





## Modelling IFC-SG (Space Usage)

### (Continued) Occupancy Type for Place of Public Resort Spaces

#### ▶ 60) Train station

Applicable for a rapid transit system:

#### ▶ 61) Air transport terminal

Applicable for an airport terminal:

#### ▶ 62) Sea transport terminal

Applicable for a ferry terminal:

#### ▶ 63) Land transport terminal

Applicable for a bus interchange or bus terminal:

SCDF		BCA		PUB	NEA
Table 1.4A Purpose Group		Table 2.2A Type of Occupancy		Accessibility Code Table 1 Building Type	
Table 1.4A Purpose Group		Table 2.2A Type of Occupancy		Sewerage and Sanitary Works (SSW)	
VII	Place of public resort (transportation)	Places of public resort and carpark	12	Transport stations, interchanges, and passenger terminals	-

### Occupancy Type for Storage Spaces

#### ▶ 64) Rail depot

#### ▶ 65) Bus depot

SCDF		BCA		PUB	NEA
Table 1.4A Purpose Group		Table 2.2A Type of Occupancy		Accessibility Code Table 1 Building Type	
Table 1.4A Purpose Group		Table 2.2A Type of Occupancy		Sewerage and Sanitary Works (SSW)	
VIII	Storage	Industrial buildings (factories, workshops, godowns, warehouses)	16	Factories, workshops, industrial buildings and office / showroom areas in warehouses	-

#### ▶ 66) Parking

Applicable for non-mechanized vehicle parking:

SCDF		BCA		PUB	NEA
Table 1.4A Purpose Group		Table 2.2A Type of Occupancy		Accessibility Code Table 1 Building Type	
Table 1.4A Purpose Group		Table 2.2A Type of Occupancy		Sewerage and Sanitary Works (SSW)	
VIII	Storage	Places of public resort and carpark	18	Vehicle parks	-

#### ▶ 67) Fully Automated Mechanized Car Park Buildings (FAMCP)

SCDF		BCA		PUB	NEA
Table 1.4A Purpose Group		Table 2.2A Type of Occupancy		Accessibility Code Table 1 Building Type	
Table 1.4A Purpose Group		Table 2.2A Type of Occupancy		Sewerage and Sanitary Works (SSW)	
VIII	Storage	Industrial buildings (factories, workshops, godowns, warehouses)	18	Vehicle parks	-



## Modelling IFC-SG (Space Usage)

### (Continued) Occupancy Type for Place of Storage Spaces

#### ► 68) Warehouse

SCDF			BCA		PUB	NEA
Table 1.4A Purpose Group		Table 2.2A Type of Occupancy	Accessibility Code Table 1 Building Type		Sewerage and Sanitary Works (SSW)	
VIII	Storage	Industrial buildings (factories, workshops, godowns, warehouses)	16	Factories, workshops, industrial buildings and office / showroom areas in warehouses	-	-

#### ► 69) Chemical/ hazmat storage

SCDF			BCA		PUB	NEA
Table 1.4A Purpose Group		Table 2.2A Type of Occupancy	Accessibility Code Table 1 Building Type		Sewerage and Sanitary Works (SSW)	
VIII	Storage	Industrial buildings (factories, workshops, godowns, warehouses)	16	Factories, workshops, industrial buildings and office / showroom areas in warehouses	-	-

#### ► 70) Storage

Applicable for all other storage spaces:

SCDF			BCA		PUB	NEA
Table 1.4A Purpose Group		Table 2.2A Type of Occupancy	Accessibility Code Table 1 Building Type		Sewerage and Sanitary Works (SSW)	
VIII	Storage	Follow dominant use	D	Follow dominant use	-	-

### Occupancy Type for Other Spaces

#### ► 71) Airbase

#### ► 72) Live firing area

#### ► 73) Training area

SCDF			BCA		PUB	NEA
Table 1.4A Purpose Group		Table 2.2A Type of Occupancy	Accessibility Code Table 1 Building Type		Sewerage and Sanitary Works (SSW)	
-	Exempted	-	-	Exempted	-	-



## Modelling IFC-SG (Space Usage)

*(Continued)* **Occupancy Type for Other Spaces**

- ▶ **74) Campsite**
- ▶ **75) Wet play field**
- ▶ **76) Reservoir**
- ▶ **77) River**
- ▶ **78) Canal**
- ▶ **79) Major drain**
- ▶ **80) Pond**
- ▶ **81) Lake**
- ▶ **82) Other waterbody**
- ▶ **83) Nature reserve**
- ▶ **84) Nature area**
- ▶ **85) School field**
- ▶ **86) Promenade**
- ▶ **87) Marina**
- ▶ **88) Quarry**

SCDF		BCA		PUB	NEA	
Table 1.4A Purpose Group	Table 2.2A Type of Occupancy	Accessibility Code Table 1 Building Type		Sewerage and Sanitary Works (SSW)	Residential / stay-in facilities #	All other spaces
-	Exempted	-	8 Parks and open spaces	-	-	-



## Modelling IFC-SG (Space Usage)

### ► Space Name Categories

Space Names have been standardized from spaces required across BCA, LTA, NEA, PUB and SCDF requirements, into the following categories:

- |  |                                       |
|--|---------------------------------------|
| 1) Living spaces   | 9) Supporting spaces for performing   |
| 2) Temporary residences                                  | 10) Entertainment, recreation spaces  |
| 3) Non-residential toilet Spaces (for spaces with WC)    | 11) Open spaces and open-sided spaces |
| 4) Resting, care, hygiene spaces (for spaces without WC) | 12) M&E spaces                        |
| 5) Commercial, work, institutional spaces                | 13) Storage spaces                    |
| 6) F&B spaces  | 14) Commuter facilities               |
| 7) Medical, healthcare spaces                            | 15) Circulation spaces                |
| 8) Assembly spaces                                       | 16) Other non-simultaneous spaces     |

There are identical Space Names duplicated across different Space Name Categories, e.g. Bedroom is listed under 1) Living spaces and 2) Temporary residences. This is because the SCDF Occupancy Load (OL) will differ depending on where the Bedroom is located.

Thus, all Spaces should be accompanied by both **SpaceName** and **OccupancyType** parameters.

### ► 1) Living spaces

S/N	Property Values to input for the IFC-SG Property “SpaceName”	Agencies with Applicable Spaces					
		BCA	LTA	NEA	PUB	SCDF	
						Functional Space	OL
1	Balcony	•				Apartment (Residential) Maisonettes (Residential)	15
2	Bedroom	•					
3	Master Bedroom	•					
4	Maid room	•					
5	Guestroom	•					
6	Bathroom	•			•		
7	Master Bath	•					
8	Maid Bath	•					
9	Yard Bath	•					
10	Dining Room, Dining Area	•					
11	Household Shelter	•					
12	Kitchen	•					
13	Living Room, Living Area	•					
14	Loft	•					
15	Private Lift Lobby	•					
16	Private Enclosed Space						
17	Service Yard	•			•		
18	Toilet	•			•		
19	Walk-in Wardrobe	•					



## Modelling IFC-SG (Space Usage)

### ► 2) Temporary residences

S/N	Property Values to input for the IFC-SG Property “SpaceName”	Agencies with Applicable Spaces					Functional Space	OL	
		BCA	LTA	NEA	PUB	SCDF			
1	Guestroom*	●				Backpacker Hotel	3		
2	Guestroom*	●				Serviced Apartment (based on per unit)	15		
3	Guestroom*	●				Guestroom, Accommodation Unit (Hotel, Hostel)	# Min 2 persons per room or 15 sqm/person, whichever is higher		
4	Guestroom*	●				Guestroom, Accommodation Unit (Capsule Hotel)	3		
5	Bedroom	●				Dormitory	4.2		
6	Staff Quarters	●				Staff Quarters	# Same as above		
7	Student Bedroom Individual	●				Student Bedroom	# Same as above		
8	Student Bedroom Multipax	●				Student Bedroom (Multipax)	3		
9	Housekeeping	●				Housekeeping	10		

\* Note that the OL of Guestroom Space will depend on what is indicated in its Occupancy Type

### ► 3) Non-residential toilet spaces (for spaces with WC)

Please ensure “TRUE/FALSE” have been indicated for the following IFC-SG properties - AmbulantDisabled, BarrierFreeAccessibility and ChildrenFriendly - in these spaces.

S/N	Property Values to input for the IFC-SG Property “SpaceName”	Agencies with Applicable Spaces					Functional Space	OL	
		BCA	LTA	NEA	PUB	SCDF			
1	Bathroom	●		●*		Bathroom	0		
2	Toilet	●		●		Toilet	0		
3	Isolation Ward Toilet	●							
4	Accessible Washroom	●				Toilet (Handicap)	0		
5	Male Toilet	●		●		Toilet (Male)	0		
6	Female Toilet	●		●		Toilet (Female)	0		
7	Unisex Toilet	●				Toilet	0		
8	Family-Friendly Washroom	●				Family-Friendly Washroom	0		
9	Washroom with Shower	●		●**		Washroom with Shower	0		
10	Powder Room	●		●		Powder Room	0		

\* NEA’s Bathroom Space refers to a Bathroom with Bench (BR) only

\*\* NEA’s Washroom with Shower Space refers only to a Bathroom with Bench (BR) or Bench with Hanger (BH).



## Modelling IFC-SG (Space Usage)

### 4) Resting, care, hygiene spaces (for spaces without WC)

Please ensure “TRUE/FALSE” have been indicated for the following IFC-SG properties - AmbulantDisabled, BarrierFreeAccessibility and ChildrenFriendly - in these spaces.

S/N	Property Values to input for the IFC-SG Property “SpaceName”	Agencies with Applicable Spaces					
		BCA	LTA	NEA	PUB	SCDF	
						Functional Space	OL
1	Bathroom	●				Bathroom	0
2	Changing Room	●				Changing Room	0
3	Female Changing Room	●				Changing Room (Female)	0
4	Male Changing Room	●				Changing Room (Male)	0
5	Locker Room	●				Locker Room	0
6	Restroom	●				Restroom	0
7	Nursing Room	●				Nursing Room	0
8	Lactation Room	●				Lactation Room	0
9	Sick Room	●				Sickroom	0
10	Shower Room	●		●*		Shower Room/ Shower Stall	0
11	Shower Stall	●		●*		Shower Room/ Shower Stall	0
12	Wash Area	●			●	Wash Area	0

\* NEA’s Shower Room Space or Shower Stall Space refers only to a Bathroom with Bench (BR) or Bench with Hanger (BH).

### 5) Commercial, work, institutional spaces

S/N	Property Values to input for the IFC-SG Property “SpaceName”	Agencies with Applicable Spaces					
		BCA	LTA	NEA	PUB	SCDF	
						Functional Space	OL
1	Archive Room (Reading)	●				Archive Room – Reading Area	5
2	Archive Room (Stack)	●				Archive Room – Stack Area	10
3	Ball Room	●				Ball Room	1.5
4	Banking Hall	●				Banking Hall	3
5	Bazaar	●				Bazaar	5
6	Business Centre	●				Business Centre/ Business Office	10
7	Business Office	●				Business Centre/ Business Office	10
8	Classroom	●				Classroom	1.5
9	Clean Room	●				Clean Room	0
10	Computer Classroom	●				Computer Classroom	5
11	Common Room	●				Common Room	1.5
12	Computer Room	●				Computer Room	5
13	Concierge	●				Concierge	3



## Modelling IFC-SG (Space Usage)

### ► (continued) 5) Commercial, work, institutional spaces

S/N	Property Values to input for the IFC-SG Property “SpaceName”	Agencies with Applicable Spaces					
		BCA	LTA	NEA	PUB	SCDF	
						Functional Space	OL
14	Conference Room	•				Conference Room	1.5
15	Consultant Room	•				Consultant Room	5
16	Crematoria	•				Crematoria	1.5
17	Dance Studio	•				Dance Studio	5
18	Department Store	•				Department Store	5
19	Design Studio	•				Design Studio	5
20	Detention Room	•				Detention Room	3
21	Exposition	•				Exposition/ Trade Fair Area	1.5
22	Trade Fair Area	•				Exposition/ Trade Fair Area	1.5
23	Filing Room	•				Filing Room/ Store	10
24	Store	•				Filing Room/ Store	10
25	Fire Command Centre	•				Fire Command Centre	10
26	Function Room	•				Function Room	1.5
27	Exhibits Gallery	•				Gallery – Exhibits	2.5
28	Choir Gallery	•				Gallery – Choir	1.5
29	Prayer Gallery	•				Gallery – Prayer	1.5
30	Seating Gallery	•				Gallery – Seating	1.5
31	Trading Gallery	•				Gallery – Trading	1.5
32	Viewing Gallery	•				Gallery - Viewing	1.5
33	Guard House	•				Guard House	10
34	Hobby Room	•				Hobby Room	1.5
35	Kiosk	•				Kiosk - Retail	5
36	Laboratory	•			•*	Laboratory	5
37	Laundry	•				Laundry – With Machine Operation	15
38	Library Room (Stack)	•				Library Room (Stack)	10
39	Library Room (Reading)	•				Library Room (Reading)	5
40	Lounge	•				Lounge	2.5
41	Machine/ Printing Room	•				Machine/ Printing Room	10
42	Mailroom	•				Mailroom	0
43	Meeting Room	•				Meeting Room	1.5
44	Music Studio	•				Music Studio	1.5

\* PUB’s Laboratory Space refers to the Chemical Analysis Laboratory only



## Modelling IFC-SG (Space Usage)

### ► (continued) 5) Commercial, work, institutional spaces

S/N	Property Values to input for the IFC-SG Property “SpaceName”	Agencies with Applicable Spaces					
		BCA	LTA	NEA	PUB	SCDF	
						Functional Space	OL
45	Night Club	•				Night Club	1.5
46	Admin Office	•				Office – Admin/ General	10
47	General Office	•				Office – Admin/ General	10
48	Ancillary Office	•				Office – Ancillary	7.5
49	Director Office	•				Office – Director/ Manager	15
50	Manager Office	•				Office – Director/ Manager	15
51	Drafting Office	•				Office - Drafting	5
52	Outdoor Display Area	•				Outdoor Display Area	5
53	Packing Area	•				Packing Area/ Distribution Area	10
54	Distribution Area	•				Packing Area/ Distribution Area	10
55	Pantry	•				Pantry	0
56	Prayer Hall	•				Prayer Hall	1.5
57	Prayer room	•				Prayer room	0
58	Male prayer room	•				Male prayer room	0
59	Female prayer room	•				Female prayer room	0
60	Pre-Function Room	•				Pre-Function Room	0
61	Production Area	•				Production Area	10
62	Promotion Area	•				Promotion Area	1.5
63	Reading Room	•				Reading Room	5
64	Reception Area	•				Reception Area	3
65	Seminar Room	•				Seminar Room	1.5
66	Security Room	•				Security Room	10
67	Service Area	•				Service Area	10
68	Shed	•				Shed	1.5
69	Shop	•				Shop	5
70	Showflat	•				Showflat	5
71	Showroom	•				Showroom	5
72	Society Room	•				Society Room	1.5
73	Spray Painting Room	•				Spray Painting Room	10
74	Staff Office	•				Staff Office	10
75	Staff Lounge	•				Staff Lounge	3





## Modelling IFC-SG (Space Usage)

### ► (continued) 5) Commercial, work, institutional spaces

S/N	Property Values to input for the IFC-SG Property “SpaceName”	Agencies with Applicable Spaces					
		BCA	LTA	NEA	PUB	SCDF	
						Functional Space	OL
76	Supermarket	•			•	Supermarket	5
77	Therapy Centre	•				Therapy Centre	10
78	Ticketing Office	•				Ticketing Office	10
79	Trading Floor	•				Trading Floor	2
80	Visitors Lounge	•				Visitors Lounge	3
81	Waiting Area	•				Waiting Area	3
82	Workshop*	•				Workshop - Institutional	5
83	Workshop*	•				Workshop - Industrial	10

\*\* Note that the OL of Workshop Space will depend on what is indicated in its Occupancy Type

### ► 6) F&B spaces

S/N	Property Values to input for the IFC-SG Property “SpaceName”	Agencies with Applicable Spaces					
		BCA	LTA	NEA	PUB	SCDF	
						Functional Space	OL
1	Bar	•				Bar/ Pub	1
2	Pub	•				Bar/ Pub	1
3	Cafe	•				Cafe	1
4	Cafeteria	•				Cafeteria	1.5
5	Canteen	•			•	Canteen	1.5
6	Dining Area*	•				Dining Area – Coffee Shop, Eating House, Food Court, Hawker Centre	1.5
7	Dining Area*	•				Dining Area – Fast Food Outlet	1
8	Dining Area*	•				Dining Area (that are not Coffee Shop, Eating House, Food Court, Hawker Centre or Fast Food Outlet)	1.5
9	Food Stall	•			•	Food Stall	10
10	Kiosk	•				Kiosk – Take-away F&B	5
11	Kitchen	•			•	Kitchen/ Service Area/ Service Counter	10
12	Service Area	•			•	Kitchen/ Service Area/ Service Counter	10
13	Service Counter	•			•	Kitchen/ Service Area/ Service Counter	10
14	Restaurant	•				Restaurant	1.5
15	Snack Bar	•				Snack Bar	1.5
16	Staff Canteen	•				Staff Canteen	1.5

\* Note that the OL of Dining Area Space will depend on what is indicated in its Occupancy Type



## Modelling IFC-SG (Space Usage)

### ► 7) Medical, healthcare spaces

S/N	Property Values to input for the IFC-SG Property “SpaceName”	Agencies with Applicable Spaces					
		BCA	LTA	NEA	PUB	SCDF	
						Functional Space	OL
1	Area of Refuge*	●				Area of Refuge – Ambulatory Care Facility	1.4
2	Area of Refuge*	●				Area of Refuge – Custodian Care Facility	1.4
3	Area of Refuge*	●				Area of Refuge – Custodian Care Facility (Nursery)	0
4	Area of Refuge*	●				Area of Refuge – Hospital Space with Patient Accommodation	2.8
5	Area of Refuge*	●				Area of Refuge – Hospital Space without Patient Accommodation	0.56
6	Area of Refuge*	●				Area of Refuge – Nursing Care Facility Space with Patient Accommodation	2.8
7	Area of Refuge*	●				Area of Refuge – Nursing Care Facility Space without Patient Accommodation	0.56
8	Area of Refuge*	●				Area of Refuge – Supervisory Care Facility	0.56
9	Clinic	●				Clinic (Outpatient)	5
10	Consultation Room	●				Clinic (Outpatient) – Consultation Room	5
11	Examination Room	●				Examination Room	5
12	Surgical Viewing Gallery	●				Gallery – Surgical Viewing	3
13	Laboratory	●				Laboratory – Healthcare Occupancy	20
14	Nursing Station	●				Nursing Station	10
15	Operation Theatre	●				Operation Theatre	7.5
16	Outpatient Waiting Area	●				Outpatient Waiting Area	1.5
17	Patient Accommodation Intensive Care	●				Patient Accommodation – Intensive Care	20
18	Patient Accommodation Ward	●				Patient Accommodation – Ward	10
19	Isolation Ward	●				Isolation Ward	10
20	Pharmacy Staff Area	●				Pharmacy – Staff Area	10
21	Pharmacy Waiting Area	●				Pharmacy – Public Waiting Area	2
22	Treatment Room	●				Treatment Room	5

\* Note that the OL of Area of Refuge Space will depend on what is indicated in its Occupancy Type



## Modelling IFC-SG (Space Usage)

### ► 8) Assembly Spaces

For OL that require indication of benches or seating in the Assembly Space, please indicate these components in the model.

S/N	Property Values to input for the IFC-SG Property “SpaceName”	Agencies with Applicable Spaces					Functional Space	OL
		BCA	LTA	NEA	PUB	SCDF		
1	Amphitheatre	•		•		Amphitheatre with Fixed Bench Seating	0.45m of length of benches per person	
2	Amphitheatre	•		•		Amphitheatre with Individual Fixed Seating	Based on number of fixed seating	
3	Amphitheatre without fixed seating	•		•		Amphitheatre without Individual Fixed Seating, Bench	1.5	
4	Auditorium	•		•		Auditorium – with Fixed Bench Seating	0.45m of length of benches per person	
5	Auditorium	•		•		Auditorium – with Individual Fixed Seating	Based on number of fixed seating	
6	Auditorium without fixed seating	•		•		Auditorium – without Individual Fixed Seating, Bench	1.5	
7	Cinema	•		•		Cinema – with Fixed Bench Seating	0.45m of length of benches per person	
8	Cinema	•		•		Cinema – with Individual Fixed Seating	Based on number of fixed seating	
9	Cinema without fixed seating	•		•		Cinema – without Individual Fixed Seating, Bench	1.5	
10	Grandstand	•		•*		Grandstand – with Fixed Bench Seating	0.45m of length of benches per person	
11	Grandstand	•		•*		Grandstand – with Individual Fixed Seating	Based on number of fixed seating	
12	Grandstand without fixed seating	•		•*		Grandstand – without Individual Fixed Seating, Bench	1.5	
13	Assembly Hall	•		•		Hall – Assembly Hall with Fixed Bench Seating	0.45m of length of benches per person	
14	Assembly Hall	•		•		Hall – Assembly Hall with Individual Fixed Seating	Based on number of fixed seating	
15	Assembly Hall without fixed seating	•		•		Hall – Assembly Hall without Individual Fixed Seating, Bench	1.5	
16	Concert Hall	•		•		Hall – Concert Hall with Fixed Bench Seating	0.45m of length of benches per person	
17	Concert Hall	•		•		Hall – Concert Hall with Individual Fixed Seating	Based on number of fixed seating	
18	Concert Hall without fixed seating	•		•		Hall – Concert Hall without Individual Fixed Seating, Bench	1.5	

\* NEA’s Grandstand-related Spaces refer to Stadium Spaces only



## Modelling IFC-SG (Space Usage)

### ► (continued) 8) Assembly Spaces

For OL that require indication of benches or seating in the Assembly Space, please indicate these components in the model.

S/N	Property Values to input for the IFC-SG Property “SpaceName”	Agencies with Applicable Spaces					
		BCA	LTA	NEA	PUB	SCDF	
						Functional Space	OL
19	Exhibition Hall	•		•		Hall – Exhibition Hall with Fixed Bench Seating	0.45m of length of benches per person
20	Exhibition Hall	•		•		Hall – Exhibition Hall with Individual Fixed Seating	Based on number of fixed seating
21	Exhibition Hall without fixed seating	•		•		Hall – Exhibition Hall without Individual Fixed Seating, Bench	1.5
22	Conference Hall	•		•		Hall – Conference Hall with Fixed Bench Seating	0.45m of length of benches per person
23	Conference Hall	•		•		Hall – Conference Hall with Individual Fixed Seating	Based on number of fixed seating
24	Conference Hall without fixed seating	•		•		Hall – Conference Hall without Individual Fixed Seating, Bench	1.5
25	Function Hall	•		•		Hall – Function Hall with Fixed Bench Seating	0.45m of length of benches per person
26	Function Hall	•		•		Hall – Function Hall with Individual Fixed Seating	Based on number of fixed seating
27	Function Hall without fixed seating	•		•		Hall – Function Hall without Individual Fixed Seating, Bench	1.5
28	Lecture Room	•				Lecture Room with Fixed Bench Seating	0.45m of length of benches per person
29	Lecture Room	•				Lecture Room with Individual Fixed Seating	Based on number of fixed seating
30	Lecture Room without fixed seating	•				Lecture Room without Individual Fixed Seating, Bench	1.5
31	Spectator Area	•		•		Spectator Area with Fixed Bench Seating	0.45m of length of benches per person
32	Spectator Area	•		•		Spectator Area with Individual Fixed Seating	Based on number of fixed seating
33	Spectator Area without fixed seating	•		•		Spectator Area without Individual Fixed Seating, Bench	1.5
34	Theatre	•		•		Theatre with Fixed Bench Seating	0.45m of length of benches per person
35	Theatre	•		•		Theatre with Individual Fixed Seating	Based on number of fixed seating
36	Theatre without fixed seating	•		•		Theatre without Individual Fixed Seating, Bench	1.5



## Modelling IFC-SG (Space Usage)

### ► (continued) 8) Assembly Spaces

S/N	Property Values to input for the IFC-SG Property “SpaceName”	Agencies with Applicable Spaces					
		BCA	LTA	NEA	PUB	SCDF	
						Functional Space	OL
37	Indoor Sports Hall*	●				Indoor Sports Hall – School With Multi-Purpose Hall	3
38	Indoor Sports Hall*	●				Indoor Sports Hall – School Without Multi-Purpose Hall	1
39	Multi-purpose Hall*	●		●**		Multi-purpose Hall/ Room – School/ Colleges	1
40	Multi-Purpose Room*	●		●**		Multi-purpose Hall/ Room – School/ Colleges	1
41	Multi-purpose Sports Hall*	●				Multi-purpose Sports Hall – Public Sports Complex	3
42	Multi-purpose Sports Hall*	●				Multi-purpose Sports Hall – Public Swimming Complex	3
43	Multi-purpose Sports Hall*	●		●**		Multi-purpose Sports Hall – Stadium	3

\* Note that the OL of Indoor Sports Hall, Multi-purpose Hall, Multi-purpose Room, Multi-purpose Sports Hall Spaces will depend on what is indicated in each Space’s Occupancy Type

\*\* NEA’s Multi-purpose Hall, Multi-purpose Room and Multi-purpose Sports Hall Spaces refer to Stadium Spaces only

### ► 9) Supporting spaces for performing

S/N	Property Values to input for the IFC-SG Property “SpaceName”	Agencies with Applicable Spaces					
		BCA	LTA	NEA	PUB	SCDF	
						Functional Space	OL
1	Audio Visual Area	●				Audio Visual Area	3
2	Audio Visual Control Room	●				Audio Visual Control Room – Auditorium/ Theatre/ Cinema/ Hall	5
3	Audio Visual Lighting Control Room	●				Lighting Control Room – Auditorium/ Theatre/ Cinema/ Hall	5
4	Live Entertainment	●				Live Entertainment	3
5	Live Performance	●				Live Performance	3
6	Orchestral Pit	●				Orchestral Pit	1.5
7	Projection Room	●				Projection Room – Auditorium/ Theatre/ Cinema/ Hall	5
8	Back Stage	●				Stage, Back	3
9	Front Stage***	●				Stage, Front – Schools/Colleges/ Tertiary Institutions	3
10	Front Stage***	●				Stage, Front – Auditorium/ Theatre/ Cinema/ Hall	0

\*\*\* Note that the OL of Front Stage will depend on what is indicated in each Space’s Occupancy Type



## Modelling IFC-SG (Space Usage)

### ► 10) Entertainment, recreation spaces

S/N	Property Values to input for the IFC-SG Property “SpaceName”	Agencies with Applicable Spaces					
		BCA	LTA	NEA	PUB	SCDF	
						Functional Space	OL
1	Amusement Park	●		●*		Amusement Park (excluding Machine Area)	1
2	Billiards Room	●		●*		Billiards Room	5
3	Body Massage	●		●*		Body Massage	5
4	Bowling Alley	●		●*		Bowling Alley (excluding Bowling Lane)	1
5	Bowling Lane	●		●*		Bowling Lane	0
6	Casino	●		●*		Casino	1.5
7	Children Playground	●		●*		Children Playground	5
8	Club Room	●		●*		Club Room	1.5
9	Discotheque Dancing Area	●		●*		Discotheque	1
10	Discotheque Dining Area	●		●*		Discotheque	1
11	Hockey Field	●		●*		Field, Pitch – Hockey Field/ Hockey Pitch	22 persons
12	Hockey Pitch	●		●*		Field, Pitch – Hockey Field/ Hockey Pitch	22 persons
13	Rugby Field	●		●*		Field, Pitch – Rugby Field/ Rugby Pitch	30 persons
14	Rugby Pitch	●		●*		Field, Pitch – Rugby Field/ Rugby Pitch	30 persons
15	Soccer Field	●		●*		Field, Pitch – Soccer Field/ Soccer Pitch	22 persons
16	Soccer Pitch	●		●*		Field, Pitch – Soccer Field/ Soccer Pitch	22 persons
17	Fitness Corner	●		●*		Fitness Corner/ Exercise Corner/ Health Corner	5
18	Foot Reflexology	●		●*		Foot Reflexology	5
19	Fitness Club	●		●*		Fitness Centre/ Exercise Centre/ Health Club/ Health Centre	5
20	Fitness Centre	●		●*		Fitness Centre/ Exercise Centre/ Health Club/ Health Centre	5
21	Gaming Centre	●		●*		Gaming Centre (excluding Machine Area)	1.5
22	Gymnasium	●		●*	●	Gymnasium	3.5
23	Health Club	●		●*		Health Club/ Health Centre	5
24	Health Centre	●		●*		Health Club/ Health Centre	5
25	Indoor Games Room	●		●*		Indoor Games Room	1.5
26	Karaoke Lounge	●		●*		Karaoke Lounge	1.5
27	Karaoke Dining Area	●		●*		Karaoke Dining Area	1.5
28	Recreation Room	●		●*		Recreation Room	1.5
29	Refreshment Area	●		●*		Refreshment Area	1.5

\* NEA’s Spaces refer to Shopping Mall Spaces and Stadium Spaces only



## Modelling IFC-SG (Space Usage)

### ► 10) (continued) Entertainment, recreation spaces

S/N	Property Values to input for the IFC-SG Property “SpaceName”	Agencies with Applicable Spaces					
		BCA	LTA	NEA	PUB	SCDF	
						Functional Space	OL
30	Skating Rink	●		●*		Skating Rink – Rink Area	3
31	Spa	●				Spa	5
32	Badminton Court	●				Sports Court – Badminton Court	4 persons per court
33	Basketball Court	●				Sports Court – Basketball Court	10 persons per court
34	Basketball Half Court	●				Sports Court – Basketball Court (Half-court)	6 persons per court
35	Futsal Court	●				Sports Court – Futsal Court	14 persons per court
36	Netball Court	●				Sports Court - Netball Court	14 persons per court
37	Netball Half Court	●				Sports Court - Netball Court (Half-court)	8 persons per court
38	Squash Court	●				Sports Court – Squash Court	2 persons per court
39	Tennis Court	●				Sports Court – Tennis Court	4 persons per court
40	Tennis Half Court	●				Sports Court – Tennis Court (Half-court)	2 persons per court
41	Volleyball Court	●				Sports Court – Volleyball Court	12 persons per court
42	Swimming Pool**	●				Swimming Pool – Condominium/ Apartment	5
43	Swimming Pool**	●				Swimming Pool – Hotel	0
44	Swimming Pool**	●				Swimming Pool – Private Club	0
45	Swimming Pool**	●		●		Swimming Pool – Public Sports Complex	2.5
46	Swimming Pool**	●		●		Swimming Pool – Public Swimming Complex	2.5
47	Swimming Pool**	●				Swimming Pool – Serviced Apartment	0
48	Swimming Pool Deck**	●				Swimming Pool Deck – Condominium/ Apartment	10
49	Swimming Pool Deck**	●				Swimming Pool Deck – Hotel	10
50	Swimming Pool Deck**	●				Swimming Pool Deck – Private Club	10
51	Swimming Pool Deck**	●		●		Swimming Pool Deck – Public Sports Complex	5
52	Swimming Pool Deck**	●		●		Swimming Pool Deck – Public Swimming Complex	5
53	Swimming Pool Deck**	●				Swimming Pool Deck – Serviced Apartment	10
54	Training Area	●				Training Area – Public Sports Complex	3
55	Training Area	●				Training Area – Public Swimming Complex	3
56	Training Area	●				Training Area - Stadium	3

\* NEA’s Spaces refer to Shopping Mall Spaces and Stadium Spaces only

\*\* Note that the OL of Swimming Pool and Swimming Pool Deck will depend on what is indicated in its Occupancy Type



## Modelling IFC-SG (Space Usage)

### ► 11) Open spaces and open-sided spaces

S/N	Property Values to input for the IFC-SG Property “SpaceName”	Agencies with Applicable Spaces					
		BCA	LTA	NEA	PUB	SCDF	
						Functional Space	
1	Backyard	•			•	-	-
2	Courtyard	•			•	-	-
3	Service Yard	•			•	Service Yard	10
4	Construction Site	•			•	Construction Site – Open To Space	0
5	Outdoor Refreshment Area	•				Outdoor Refreshment Area	1.5
6	Pavilion	•				Pavilion	1.5
7	Roof*	•				Roof (Public)	1.5
8	Roof*	•				Roof (Access for Maintenance only)	0
9	Green Roof*	•				Roof - Green Roof (Public)	1.5
10	Green Roof*	•				Roof - Green Roof (Access for Maintenance only)	0
11	Private Roof Garden	•				Roof Garden/ Roof Terrace, Private (of Individual Residential Unit)	0
12	Jogging Track	•				Roof Garden/ Roof Terrace, Public – Jogging Track/ Designated Foot Path ≤ 3m in width	3
13	Footpath	•				Roof Garden/ Roof Terrace, Public – Jogging Track/ Designated Foot Path ≤ 3m in width	3
14	Roof Garden**	•				Roof Garden/ Roof Terrace, Public – Planter Box < 300mm High	1.5
15	Roof Garden**	•				Roof Garden/ Roof Terrace, Public – Planter Box ≥ 300mm, ≤ 500mm High, Covered Fully with Trees or Shrubs	0
16	Roof Garden**	•				Roof Garden/ Roof Terrace, Public – Planter Box ≥ 300mm, ≤ 500mm High, Not Covered Fully with Trees or Shrubs	1.5
17	Roof Garden**	•				Roof Garden/ Roof Terrace, Public – Planter Box > 500mm High Without Step or Ramp Access	0
18	Roof Garden**	•				Roof Garden/ Roof Terrace, Public – Planter Box > 500mm High With Step or Ramp Access	1.5
19	Roof Garden**	•				Roof Garden/ Roof Terrace, Public – Water Feature < 300mm in Depth or Height	3
20	Roof Garden**	•				Roof Garden/ Roof Terrace, Public – Water Feature ≥ 300mm in Depth or Height	0
21	Sunken Planting Area**	•				Roof Garden/ Roof Terrace, Public – Sunken Planting Area (Fully Covered with Trees or Shrubs)	0
22	Sunken Planting Area**	•				Roof Garden/ Roof Terrace, Public – Sunken Planting Area (Turf)	3
23	Roof Garden**	•				Roof Garden/ Roof Terrace, Public – Other Areas	1.5

\* Note that the OL of Roof and Green Roof Spaces will depend on what is indicated in each Space’s Occupancy Type

\*\* Note that the Roof Garden spaces must ensure the following:

- (i) Planter Boxes and Water Features are indicated if applicable
- (ii) “TRUE/FALSE” have been indicated for the following IFC-SG properties – FullyCoveredWithTreesShrub, StepRampAccess





## Modelling IFC-SG (Space Usage)

### ► 12) M&E spaces

S/N	Property Values to input for the IFC-SG Property “SpaceName”	Agencies with Applicable Spaces					OL
		BCA	LTA	NEA	PUB	SCDF	
						Functional Space	
1	Battery Room	•				Battery Room	30
2	Cooling Tower	•			•	Cooling Tower	30
3	Equipment Disinfection Room	•			•	Equipment Disinfection Room	30
4	Equipment Washing Bay	•			•	Equipment Washing Bay	10
5	Lubrication Bay	•			•	Lubrication Bay	30
6	Pulley Room	•			•	Pulley Room	30
7	Mechanical Plant Room	•				Mechanical Plant Room	30
8	AC Plant Room	•				Mechanical Plant Room – AC	30
9	AHU Room	•				Mechanical Plant Room – AHU	30
10	Boiler Room	•			•	Mechanical Plant Room – Boiler Room (Oil Fired)	30
11	Boiler Room (Oil Fired)	•			•	Mechanical Plant Room – Boiler Room (Oil Fired)	30
12	Chiller Room	•			•	Mechanical Plant Room – Chiller Room	30
13	Discharge Valve Room	•			•	Mechanical Plant Room – Discharge Valve Room	30
14	Electric Lift Motor Room	•				Mechanical Plant Room – Electric Lift Motor Room	30
15	Electrical Room	•				Mechanical Plant Room – Electrical Room	30
16	Essential Fan Room	•				Mechanical Plant Room – Essential Fan Room	30
17	Fire Pump Room	•			•	Mechanical Plant Room – Fire Pump Room	30
18	Balancing Pump Room	•			•	Balancing Pump Room	30
19	Domestic Pump Room	•			•	Domestic Pump Room	30
20	Irrigation Pump Room	•			•	Irrigation Pump Room	30
21	Potable Water Pump Room	•			•	Potable Water Pump Room	30
22	Sprinkler Pump Room	•			•	Sprinkler Pump Room	30
23	Pumped Sanitary Pump Room	•			•	Pumped Sanitary Pump Room	30
24	Pumped Drainage System Room	•			•	Pumped Drainage System Room	30
25	Ejector Room	•			•	Ejector Room	30
26	Emergency Generator Room	•			•	Mechanical Plant Room – Emergency Generator Room	30
27	Generator Room	•				Mechanical Plant Room – Generator Room	30
28	High Voltage Switch Room	•				Mechanical Plant Room – High Voltage Switch Room	30
29	Hydraulic Lift Motor Room	•				Mechanical Plant Room – Hydraulic Lift Motor Room	30



## Modelling IFC-SG (Space Usage)

### ► 12) (continued) M&E Spaces

S/N	Property Values to input for the IFC-SG Property “SpaceName”	Agencies with Applicable Spaces					OL
		BCA	LTA	NEA	PUB	SCDF	
						Functional Space	
30	Lift Machine Room	•				Mechanical Plant Room – Lift Machine Room	30
31	Lift Motor Room	•				Mechanical Plant Room – Lift Motor Room	30
32	Low Voltage Switch Room	•				Mechanical Plant Room – Low Voltage Switch Room	30
33	Oil Tank Room	•				Mechanical Plant Room – Oil Tank Room	30
34	Sprinkler Tank Room	•				Mechanical Plant Room – Sprinkler Tank Room	30
35	Telecommunication Room,	•				Mechanical Plant Room – Telecommunication Room/ Non-Essential Equipment Room	30
36	Equipment Room	•				Mechanical Plant Room – Telecommunication Room/ Non-Essential Equipment Room	30
37	Transformer Room	•				Mechanical Plant Room – Transformer Room	30
38	Wet Riser Tank Room	•				Mechanical Plant Room – Wet Riser Tank Room	30
39	Electrical Switchgear Room	•				Electrical Switchgear Room	30
40	PABX Room	•				PABX Room	30
41	Server Room	•				Server Room	30
42	MDF Room	•				MDFRoom	30
43	Mobile Installation Space	•				Mobile Installation Space/ Mobile Deployment Space	30
44	Mobile Deployment Space	•				Mobile Installation Space/ Mobile Deployment Space	30
45	Electronics Parking System Room	•				Electronics Parking System Room	30
46	Police Equipment Room	•				Police Equipment Room	30
47	Vent Room	•				Vent Room	30
48	Substation	•				Substation	30
49	Meter Compartment	•				Meter Compartment	30
50	Domestic Transfer Tank Room	•			•	Domestic Transfer Tank Room	30
51	Hosereel Tank Room	•			•	Hosereel Tank Room	30
52	Hydrant Tank Room	•			•	Hydrant Tank Room	30
53	NEWater Tank Room	•			•	NEWater Tank Room	30
54	Non-potable Water Tank Room	•			•	Non-potable Water Tank Room	30
55	Potable Water Tank Room	•			•	Potable Water Tank Room	30



## Modelling IFC-SG (Space Usage)

### ► 12) (continued) M&E Spaces

S/N	Property Values to input for the IFC-SG Property “SpaceName”	Agencies with Applicable Spaces					
		BCA	LTA	NEA	PUB	SCDF	
						Functional Space	OL
56	Balancing Tank	●			●	Balancing Tank	0
57	Detention Tank	●			●	Detention Tank	0
58	Domestic Water Tank	●			●	Domestic Water Tank	0
59	Domestic Booster Tank	●			●	Domestic Booster Tank	0
60	Hot Water Tank	●			●	Hot Water Tank	0
61	Make Up Water Tank	●			●	Make Up Water Tank	0
62	NEWater Tank	●			●	NEWater Tank	0
63	Potable Water Tank	●			●	Potable Water Tank	0
64	Pneumatic Tank	●			●	Pneumatic Tank	0
65	Rainwater Harvesting Tank	●			●	Rainwater Harvesting Tank	0
66	Irrigation Tank	●			●	Irrigation Tank	0
67	Sprinkler Tank	●			●	Sprinkler Tank	0

### ► 13) Storage spaces

S/N	Property Values to input for the IFC-SG Property “SpaceName”	Agencies with Applicable Spaces					
		BCA	LTA	NEA	PUB	SCDF	
						Functional Space	OL
1	Bin Centre	●				Bin Centre	30
2	Bin Point	●				Bin Centre	30
3	Coldroom	●				Coldroom	30
4	Deposit Room	●				Deposit Room/ Strong Room	30
5	Strong Room	●				Deposit Room/ Strong Room	30
6	Mortuary	●				Mortuary	30
7	Storage	●				Storage/ Storeroom	30
8	Storeroom	●				Storage/ Storeroom	30
9	Warehouse	●				Warehouse	30
10	Industrial Waste Storage Area	●				Industrial Waste Storage Area	30



## Modelling IFC-SG (Space Usage)

### ► 14) Commuter facilities

S/N	Property Values to input for the IFC-SG Property “SpaceName”	Agencies with Applicable Spaces					
		BCA	LTA	NEA	PUB	SCDF	
						Functional Space	OL
1	Driveway	•				Driveway	30
2	Garage	•			•	Garage	30
3	Parking Place*	•	•			Parking Area - Bicycle	30
4	Parking Place*	•	•			Parking Area – Car/ Lorry/ Bus	30
5	Parking Place*	•	•			Parking Area – Handicap	30
6	Parking Place*	•	•			Parking Area – Motorcycle	30
7	Vehicle Washing Bay	•				Parking Area – Washing	30
8	Loading/ Unloading Bay	•				Loading / Unloading Area / Bay / Platform	4 persons per bay
9	Loading Platform/ Unloading Platform	•				Loading / Unloading Area / Bay / Platform	4 persons per bay
10	Alighting Point	•				Alighting / Boarding Point	0
11	Boarding Point	•				Alighting / Boarding Point	0
12	Drop Off Point	•				Drop Off Point	0
13	Bus Stop	•				Bus Stop	0
14	Taxi Bay	•				Taxi Bay	0
15	Taxi Shelter	•				Taxi Shelter	0

\* Note that the vehicle type of Parking Place Spaces will depend on the IFC sub-type modelled for Parking Lot components. For example, a Parking Place Space for a Car should also include the IfcBuildingElementProxy > CARLOT IFC-SG component.

### ► 15) Circulation spaces

S/N	Property Values to input for the IFC-SG Property “SpaceName”	Agencies with Applicable Spaces					
		BCA	LTA	NEA	PUB	SCDF	
						Functional Space	OL
1	Atrium	•				Atrium Floor	3
2	Concourse	•				Concourse	3
3	Foyer	•				Foyer – Bus / Airport / Ferry Terminal or Station	1.5
4	Passenger Arrival Area	•				Passenger Arrival / Departure Areas – Bus / Airport / Ferry	1.5
5	Passenger Departure Area	•				Passenger Arrival / Departure Areas – Bus / Airport / Ferry	1.5



## Modelling IFC-SG (Space Usage)

### ► 15) (continued) Circulation spaces

S/N	Property Values to input for the IFC-SG Property “SpaceName”	Agencies with Applicable Spaces					
		BCA	LTA	NEA	PUB	SCDF	
						Functional Space	OL
6	Cargo Lift Lobby	•				Lobby – Cargo Lift Lobby/ Goods Lift Lobby	0
7	Goods Lift Lobby	•				Lobby – Cargo Lift Lobby/ Goods Lift Lobby	0
8	Common Lobby	•				Lobby – Common Lobby	0
9	Evacuation Lift Lobby	•				Lobby – Evacuation Lift Lobby	0
10	Fire Lift Lobby	•				Lobby – Fire Lift Lobby	0
11	Passenger Lift Lobby	•				Lobby – Passenger Lift Lobby	0
12	Protected Lobby	•				Lobby – Protected Lobby	0
13	Smoke-Free Lobby	•				Lobby – Smoke-Free Lobby	0
14	Service Lift Lobby	•				Lobby – Service Lift Lobby	0
15	Private Lift Lobby	•				Lobby – Private Lift Lobby	0
16	Equipment Platform	•				Equipment Platform	0
17	Pedestrian Linkway (with commercial activities)	•				Pedestrian linkways (aboveground or underground) - with commercial activities	2
18	Pedestrian linkway (building to Rapid Transit Stations without commercial activities)	•				Pedestrian linkways (aboveground or underground) - building to Rapid Transit Stations (e.g., Mass Rapid Transit (MRT)) without commercial activities	3.5
19	Pedestrian linkway (building to building without commercial activities)	•				Pedestrian linkways (aboveground or underground) - building to building without commercial activities	5
20	Pedestrian linkway (standalone type without commercial activities)	•				Pedestrian linkways (aboveground or underground) - standalone type without commercial activities	0
21	Promenade	•				Promenade	0
22	Boardwalk	•				Boardwalk	0
23	Through-Block Link					Through-Block Link	0
24	Access Aisle	•				Access Aisle	0
25	Private Corridor	•				Corridor (Private)	0
26	Corridor	•				Corridor – Common Corridor	0
27	External Corridor	•				Corridor – External Corridor	0
28	Open Walkway	•				Walkway	0
29	Covered Walkway	•				Walkway	0



## Modelling IFC-SG (Space Usage)

### ► 15) (continued) Circulation spaces

S/N	Property Values to input for the IFC-SG Property “SpaceName”	Agencies with Applicable Spaces					
		BCA	LTA	NEA	PUB	SCDF	
						Functional Space	OL
30	Footway	•				Footway	0
31	Pathway	•				Pathway	0
32	Veranda	•			•	Veranda	0
33	Void Deck	•			•	Void Deck	0
34	External Exit Staircase*	•				Exit – External Circular Staircase	0
35	External Exit Staircase*	•				Exit – External Exit Staircase	0
36	External Exit Staircase*	•				Exit – External Spiral Staircase	0
37	Internal Exit Staircase*	•				Exit – Internal Circular Staircase	0
38	Internal Exit Staircase*	•				Exit – Internal Exit Staircase	0
39	Internal Exit Staircase*	•				Exit – Internal Spiral Staircase	0
40	Staircase*	•				Staircase – Hardwood Staircase	0
41	Staircase*	•				Staircase – Access Staircase	0
42	External Exit Passageway	•				Exit – External Exit Passageway	0
43	Internal Exit Passageway	•				Exit – Internal Exit Passageway	0
44	External Exit Ramp**	•				Exit – External Exit Ramp	0
45	Internal Exit Ramp**	•				Exit – Internal Exit Ramp	0

\* All Staircase Spaces must include modelling of staircase components (IfcStair). IfcStair components representing Hardwood Staircases should indicate “Hardwood” for the Material parameter.

\*\* All Ramp Spaces must include modelling of ramp components (IfcRamp).



## Modelling IFC-SG (Space Usage)

### ► 16) Other non-simultaneous spaces

S/N	Property Values to input for the IFC-SG Property “SpaceName”	Agencies with Applicable Spaces					
		BCA	LTA	NEA	PUB	SCDF	
						Functional Space	OL
1	Airlock	•				Airlock	0
2	Letter Box	•				Letter Box	0
3	Dry Riser Shaft	•				Shaft – Dry Riser	0
4	Electrical Shaft	•				Shaft – Electrical	0
5	Gas Shaft	•				Shaft – Gas	0
6	Ventilation Shaft	•		•		Shaft – Ventilation	0
7	Water Shaft	•				Shaft – Water	0
8	Wet Riser Shaft	•				Shaft – Wet Riser	0
9	Lift Shaft	•				Lift Shaft	0
10	Telecommunication Shaft	•				Shaft - Telecommunication	0
11	Chilled Water Shaft	•				Shaft - Chilled Water	0
12	Sewerage Shaft	•				Shaft - Sewerage	0
13	Exhaust Shaft	•				Shaft - Exhaust	0
14	Refuse Chute	•				Refuse Chute	0
15	Recyclables Chute	•				Recyclables Chute	0
16	Household non-Shelter	•				CD shelter - Household non-shelter	0
17	Storey Shelter	•				CD shelter - Storey shelter	0
18	Storey non-Shelter	•				CD shelter - Storey non-shelter	0
19	Staircase Storey Shelter	•				CD shelter - Staircase storey shelter	0
20	Staircase Storey non-Shelter	•				CD shelter - Staircase storey non-shelter	0
21	Rest Area	•				-	0
22	Airwell	•			•	-	-

## Space

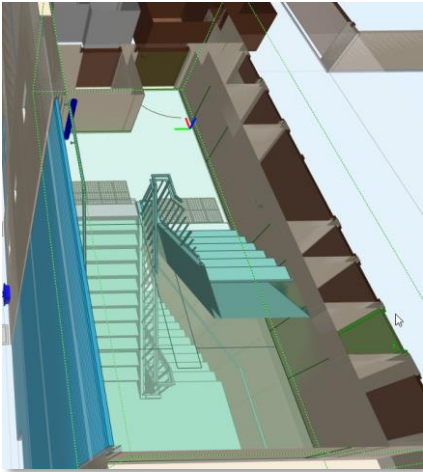

S4 – Fig 91 : Fire Exit Staircase

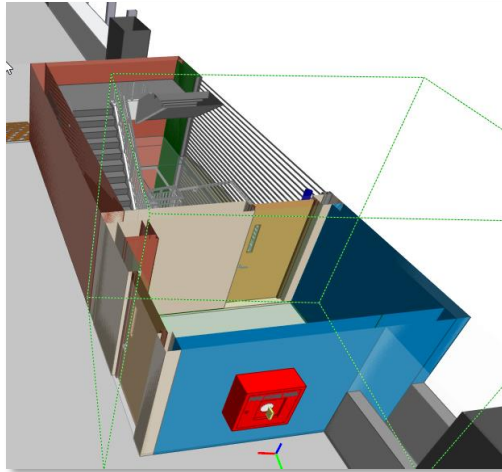

S4 – Fig 92 : Smoke Stop Lobby

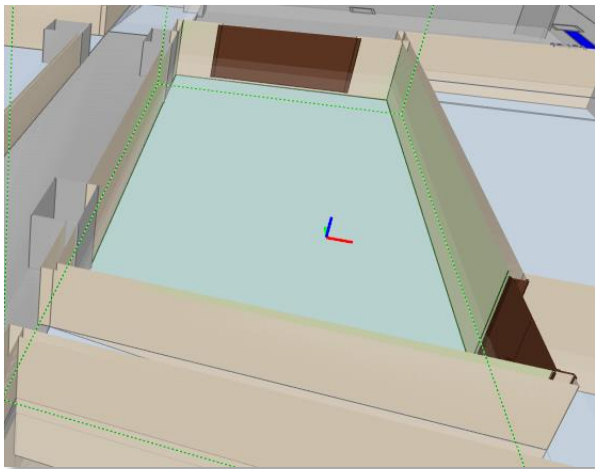

S4 – Fig 93 : Bin Centre

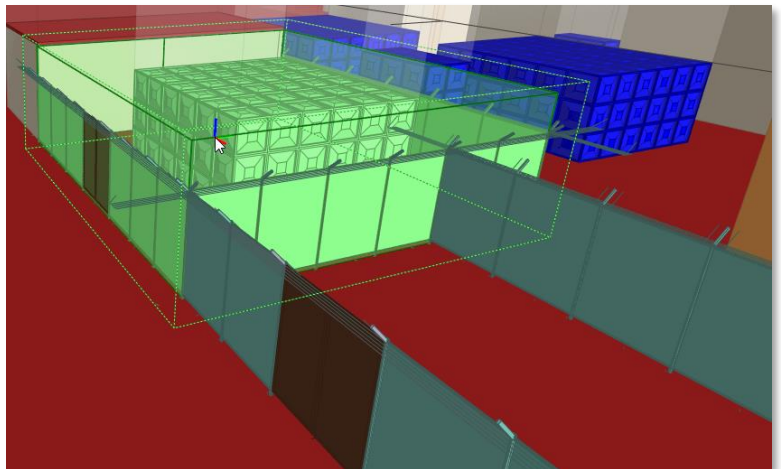

S4 – Fig 94 : Water Pump Room

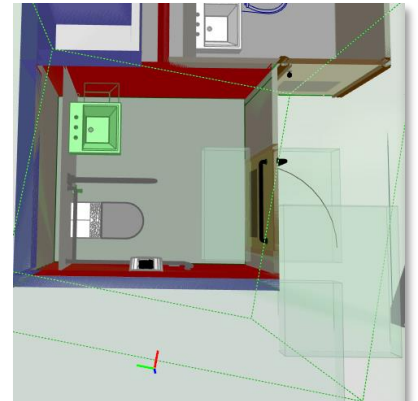
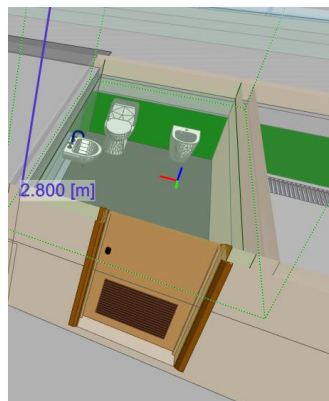
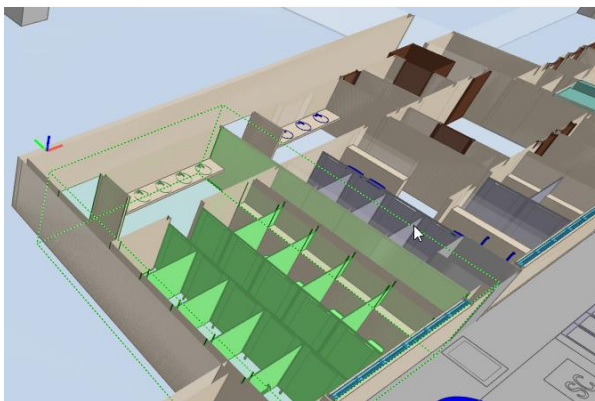

S4 – Fig 95 to 97 : Toilet



## Modelling IFC-SG (Other Spaces)

### ► Other Space Usage IFC-SG parameters

In addition to Occupancy Type and Space Name parameters and values listed earlier, some space components may require additional parameters listed below.

IFC Entity: <b>IfcSpace</b>						
IFC SubType: -						
S/N	IFC-SG Property	Property Type	Type of Elements	Unit	Input Limitation	Examples
1	Accreditation_PAS	Boolean	-	-	Yes	TRUE / FALSE
2	Area	Area	-	m <sup>2</sup>	-	-
3	AmbulantDisabled	Boolean	-	-	Yes	TRUE / FALSE
4	BarrierFreeAccessibility	Boolean	-	-	Yes	TRUE / FALSE
5	ChildrenFriendly	Boolean	-	-	Yes	TRUE / FALSE
6	CValue	Text	-	-	No	0.45 - 1
7	ElderlyFriendly	Boolean	-	-	Yes	TRUE / FALSE
8	EmergencyVoiceCommunicationSystem	Text	-	-	Yes	1-way EVC System, 2-way EVC System, Public Address System.
9	FireDetectionAndSuppressionSystem	Text	-	-	Yes	Automatic Fire Alarm System, Automatic Sprinkler System, Water Mist System, Video Image Fire Detector System, Kitchen Hood Fire Extinguishing System, Clean Agent Fire Extinguishing System, Automatic Foam Sprinkler System, Foam Extinguisher System
10	FireEmergencyVentilationMode	Text	-	-	Yes	Natural Ventilation, Mechanical Ventilation, Pressurisation, Cross-ventilation, Cross-ventilation with Intermediate Ventilation Opening, Vapour Extraction System (for spray painting room)
11	FireExit	Boolean	-	-	Yes	TRUE / FALSE
12	FullyCoveredWithTreesShrubs	Boolean	-	-	Yes	TRUE / FALSE
13	HearingEnhancement	Boolean	-	-	Yes	TRUE / FALSE
14	Height	Length	-	mm	-	-

## Modelling IFC-SG (Space – Usage)

### ► Other Space Usage IFC-SG parameters (continued from previous page)

IFC Entity: <b>lfcSpace</b>						
IFC SubType: -						
S/N	IFC-SG Property	Property Type	Type of Elements	Unit	Input Limitation	Examples
15	LargerAccessible	Boolean	-	-	Yes	TRUE / FALSE
16	OccupancyLoad	Real	-	-	No	-
17	OccupancyType	Text	-	-	Yes	Refer to list of Occupancy Types in <a href="#">Modelling IFC-SG (Space Usage) chapter</a>
18	ParkingType	Text	-	-	No	Bicycle, Motorcycle
19	PurposeGroup	Text	-	-	No	I, II, III
20	RefuseOutput	Real	-	-	No	120, 200-
21	Retrofit	Boolean	-	-	Yes	TRUE / FALSE
22	SmokeControlSystem	Text	-	-	Yes	Smoke Vent, Smoke Purging System, Ductless Jet Fan System, Engineered Smoke Control System
23	SoundPowerLevel	Text	-	-	-	-
24	SoundPressureLevel	Text	-	-	-	-
25	SpaceName	Text	-	-	Yes	Refer to list of Space Names in <a href="#">Modelling IFC-SG (Space Usage) chapter</a>
26	StepRampAccess	Boolean	-	-	Yes	TRUE / FALSE
27	TwentyFourHourMannedStation	Boolean	-	-	Yes	TRUE / FALSE
28	UnitNumber	Text	-	-	-	-
29	VentilationMode	Text	-	-	Yes	Natural Ventilation, Air Conditioning, Mechanical Ventilation, Mechanical Ventilation
30	VentilationType	Text	-	-	-	Cross Ventilation
31	Volume	Length	-	-	-	-

## Sprinkler (Non-Fire; For NEA)

Legend: ■ Architecture ■ C&S ■ M&E

### ► By IFC Representation

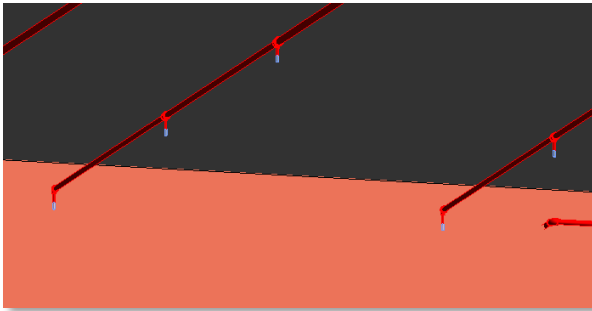

S4 – Fig 98 : Exposed Sprinkler

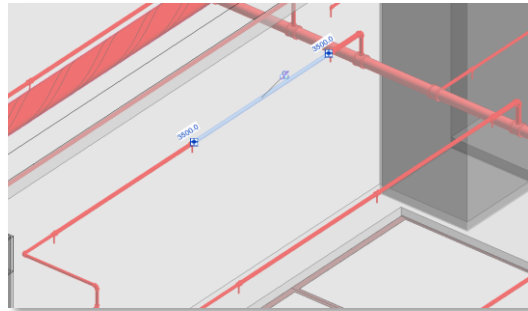

S4 – Fig 99 : Sprinkler



S4 – Fig 100 : Sprinkler

<b>IFC Entity:</b> <a href="#">IfcSanitaryTerminal</a>						
<b>IFC SubType:</b> SPRINKLER						
S/N	IFC-SG Property	Property Type	Type of Elements	Unit	Input Limitation	Examples
-	-	-	-	-	-	-

#### Notes

- Refer to [Space Usage \(Others\)](#) for representation of Sprinkler for Fire Protection purposes

## Staircase

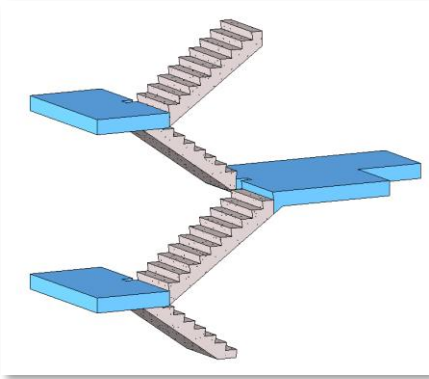

S4 – Fig 101 : Precast Staircase

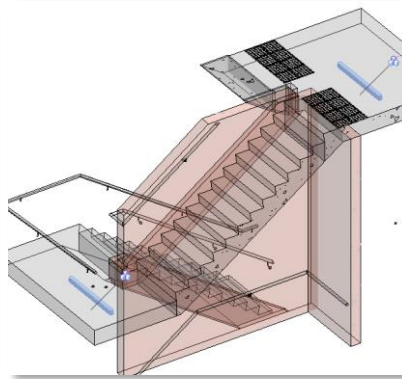

S4 – Fig 102 : Staircase

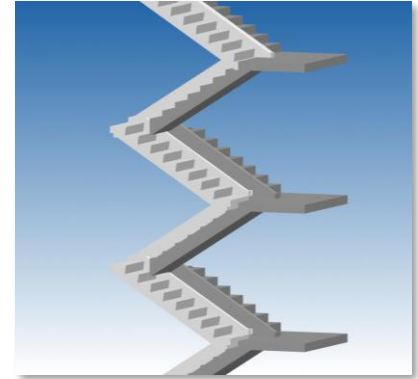

S4 – Fig 103 : Staircase

### ► Modelling Staircase in IFC-SG

- All the stair elements shall be modelled in IFC-SG model with the necessary information required as stipulated in the tables below.
  - The reinforcement for stair shall be indicated in IFC-SG parameters and substantiate with stair reinforcement details in 2D drawings.
- 2D detail drawings are allowed for the connection details of stairs with the indication of drawing number in the IFC-SG parameter “ReferTo2DDetail”.

### ► By IFC Representation

IFC Entity: <b>IbcStair</b>						
IFC SubType: N.A., CURVED_RUN_STAIR, SPIRAL_STAIR, STRAIGHT_RUN_STAIR, DOUBLE_RETURN_STAIR, HALF_TURN_STAIR, QUARTER_TURN_STAIR, THREE_QUARTER_TURN_STAIR						
S/N	IFC-SG Property	Property Type	Type of Elements	Unit	Input Limitation	Examples
1	MaterialGrade	Text	All staircase	-	Yes	Refer to list <sup>^</sup>
2	Mark	Text	All staircase	-	No	ST1, ST-A1
3	ReferTo2DDetail	Text	When required / relevant	-	No	Dwg number
4	ReinforcementSteelGrade	Text	RC staircase	-	No	Refer to list <sup>^</sup>
5	SectionFabricationMethod	Text	Steel staircase	-	No	Refer to list <sup>^</sup>
6	ConstructionMethod	Text	RC staircase	-	No	Refer to list <sup>^</sup>
7	MemberSection	Text	Steel staircase	-	No	RHS600x30x4, CHS500x3.0, 254x254x63kg/m
8	Thickness	Length	All staircase	mm	No*	150
9	Width	Length	All staircase	mm	No*	2200
10	BottomDistribution	Text	RC staircase	-	Yes	H25-150+H16-300

\* Parameter is populated from the dimensions of BIM elements modelled.

<sup>^</sup> List can be found [here](#).

## Staircase

### ► By IFC Representation (continued from previous page)

IFC Entity: <b>IbcStair</b>						
IFC SubType: N.A., CURVED_RUN_STAIR, SPIRAL_STAIR, STRAIGHT_RUN_STAIR, DOUBLE_RETURN_STAIR, HALF_TURN_STAIR, QUARTER_TURN_STAIR, THREE_QUARTER_TURN_STAIR						
S/N	IFC-SG Property	Property Type	Type of Elements	Unit	Input Limitation	Examples
11	BottomMain	Text	RC staircase	-	Yes	H25-150+H16-300
12	TopDistribution	Text	RC staircase	-	Yes	H25-150+H16-300
13	TopMain	Text	RC staircase	-	Yes	H32-150+H20-300
14	ConnectionDetailsBottom	Text	When required / relevant	-	No	Detail 1
15	ConnectionDetailsTop	Text	When required / relevant	-	No	Detail 1
16	ConnectionTypeBottom	Text	When required / relevant	-	Yes	Refer to list <sup>^</sup>
17	ConnectionTypeTop	Text	When required / relevant	-	Yes	Refer to list <sup>^</sup>
18	FireExit	Boolean	When required / relevant	-	Yes	TRUE / FALSE
19	Accreditation_PAS	Boolean	-	-	Yes	TRUE / FALSE
20	MechanicalConnectionType	Text	-	-	No	-

IFC Entity: <b>IbcStairFlight</b>						
IFC SubType: N.A., CURVED, SPIRAL, WINDER, STRAIGHT						
S/N	IFC-SG Property	Property Type	Type of Elements	Unit	Input Limitation	Examples
1	NumberOfRisers	Integer	All staircase	-	No	-
2	RiserHeight	Length	All staircase	mm	No	-
3	NumberOfTreads	Integer	All staircase	-	No	-
4	TreadLength	Length	All staircase	mm	No	-
5	MaterialGrade	Text	All staircase	-	Yes	Refer to list <sup>^</sup>
6	ConstructionMethod	Text	RC staircase	-	No	Refer to list <sup>^</sup>
7	MechanicalConnectionType	Text	-	-	No	-

<sup>^</sup> List can be found [here](#).

\* Parameter is populated from the dimensions of BIM elements modelled.

## Staircase

### ► Example of Staircase (RC Staircase) Structural Element Input

150mm thick RC Precast Stair Flight	IFC Entity: <b>IbcStair</b>			
	IFC SubType: N.A.			
<ul style="list-style-type: none"> <li>• Mark – SC2</li> <li>• Width – 1.6m</li> <li>• Concrete grade C32/40</li> <li>• From 1<sup>st</sup> storey to 2<sup>nd</sup> storey</li> <li>• Main rebar H10-200 top &amp; bottom</li> <li>• Distribution bar H10-200 top &amp; bottom</li> <li>• Typical precast staircase connection</li> </ul>	S/N	IFC-SG Property	Examples	
		1	MaterialGrade	C32/40
		2	Mark	SC2
		3	ReinforcementSteelGrade	500B
		4	ConstructionMethod	PC
		5	Thickness	150
		6	Width	1600
		7	BottomDistribution	H10-200
		8	BottomMain	H10-200
		9	TopDistribution	H10-200
		10	TopMain	H10-200
		11	ConnectionDetailsBottom	Typical precast staircase connection
		12	ConnectionDetailsTop	Typical precast staircase connection
		13	ConnectionTypeBottom	Pinned
	14	ConnectionTypeTop	Pinned	

## System

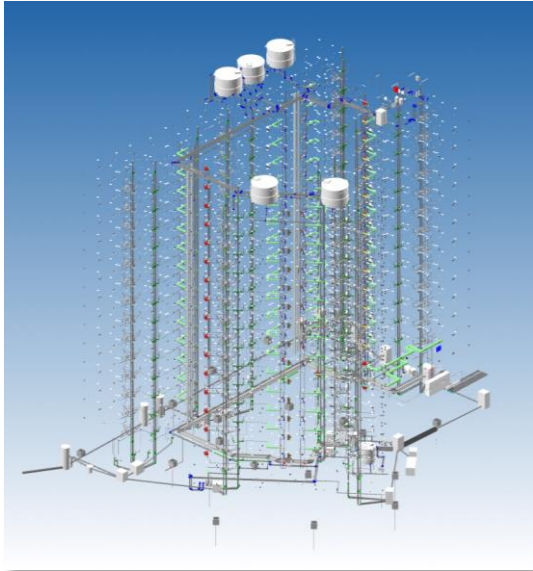

S4 – Fig 104 : Combined System(s)

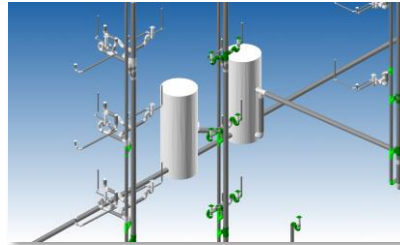

S4 – Fig 105 : Sanitary System

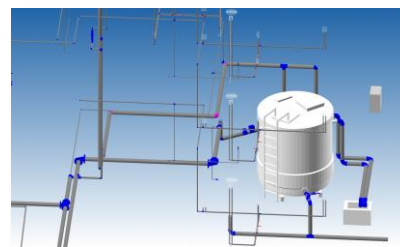

S4 – Fig 106 : Plumbing System

### ► By IFC Representation

IFC Entity: <b>lfcDistributionSystem</b>						
IFC SubType: CHILLEDWATER, DOMESTICCOLDWATER, DRAINAGE, DRYRISER, FOAMFIREEXTINGUISHING, FOAMSPRINKLER, POTABLEWATER, RAINWATER, SANITARY, SEWAGE, SPRINKLER, WETRISER						
S/N	IFC-SG Property	Property Type	Type of Elements	Unit	Input Limitation	Examples
1	Material	Text	-	-	-	-
2	Diameter	Length	-	mm	-	-
3	Gradient	Text	-	-	-	-
4	Length	Length	-	mm	-	-
5	Height	Length	-	mm	-	-
6	TradeEffluent	Boolean	-	-	Yes	TRUE / FALSE

#### Notes

- The Foam Fire Extinguishing System should include Foam Inlet and Foam Outlet components.
- The Wet Riser System and Dry Riser System should include [Breeching Inlet](#) and [Landing Valve](#) components.
- The Foam Sprinkler System and Sprinkler System should include [Breeching Inlet](#) components.
- Refer to [Space Usage \(Others\)](#) for representation of rest of Fire Protection Systems

# Tank

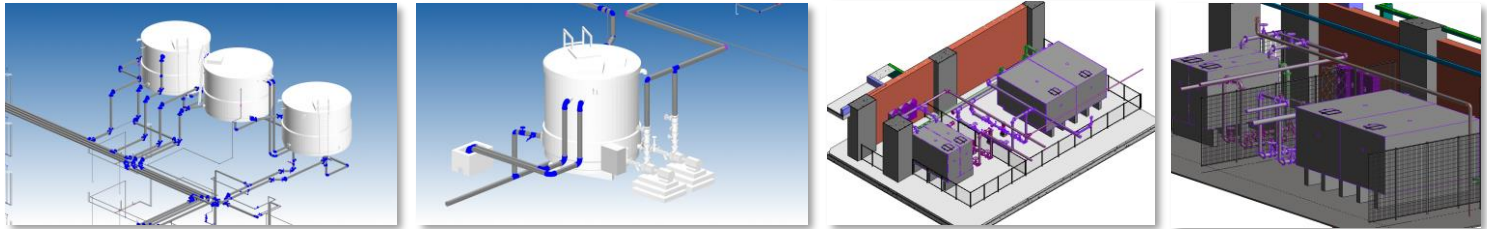

S4 – Fig 107 to 110 : Water Tank

## ► By IFC Representation

IFC Entity: <b>lfcTank</b>						
IFC SubType: STORAGE, DETENTIONTANK, RAINWATERHARVESTINGTANK, IRRIGATIONTANK, SPRINKLERTANK, BALANCINGTANK, SECTIONAL, REFUSEHANDLINGEQUIPMENT, VESSEL, RECHARGEWELL						
S/N	IFC-SG Property	Property Type	Type of Elements	Unit	Input Limitation	Examples
1	IsPotable	Boolean	-	-	Yes	TRUE / FALSE
2	NominalCapacity	Real	-	-	-	-
3	Diameter	Length	-	mm	No	-
4	Height	Length	-	mm	No	-
5	Length	Length	-	mm	No	-
6	Thickness	Length	-	mm	No	-
7	Width	Length	-	mm	No	-
8	TradeEffluent	Boolean	-	-	Yes	TRUE / FALSE
9	CompactionRatio	Text	-	-	No	-
10	EquipmentType	Text	-	-	No	-
11	TradeEffluent	Boolean	-	-	Yes	TRUE / FALSE

## ► RC Tank

IFC Entity: <b>lfcSpace</b>						
IFC SubType: N.A.						
S/N	IFC-SG Property	Property Type	Type of Elements	Unit	Input Limitation	Examples
1	Area	Length	-	m <sup>2</sup>	-	-
2	Height	Length	-	mm	-	-
3	SpaceName	Text	-	-	-	-
4	Volume	Text	-	-	-	-
5	IsPotable	Boolean	-	-	Yes	TRUE / FALSE
6	NominalCapacity	Real	-	-	-	-
7	Thickness	Length	-	mm	No	-



## Type Bedding for Pipe

### ► By IFC Representation

<b>IFC Entity:</b> <a href="#">IfcPipeSegment</a>						
<b>IFC SubType:</b> FOUNDATION						
S/N	IFC-SG Property	Property Type	Type of Elements	Unit	Input Limitation	Examples
1	BeddingType	Text	-	-	-	Type 1, Type 2, Type 3

# Valve

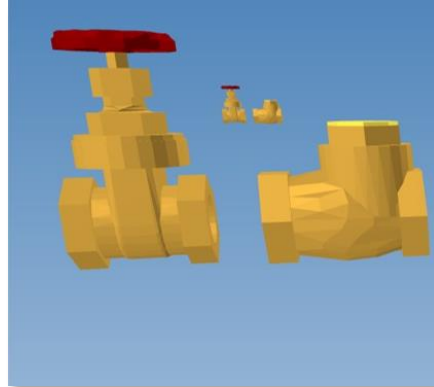

S4 – Fig 111 : Valve

## ► By IFC Representation

<b>IFC Entity:</b> <a href="#">IfcValve</a>						
<b>IFC SubType:</b> LANDINGVALVE, SPRINKLERCONTROL, DOUBLECHECK, MIXING, AIRADMITTANCE, DRAINOFFCOCK, CHECK, ISOLATING						
S/N	IFC-SG Property	Property Type	Type of Elements	Unit	Input Limitation	Examples
-	-	-	-	-	-	-

### Notes

- Ensure the Landing Valve is also exported as part of the [Wet Riser System and Dry Riser System](#)

# Wall

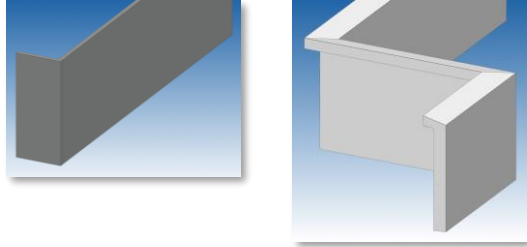

S4 – Fig.111 : Wall (Parapet)

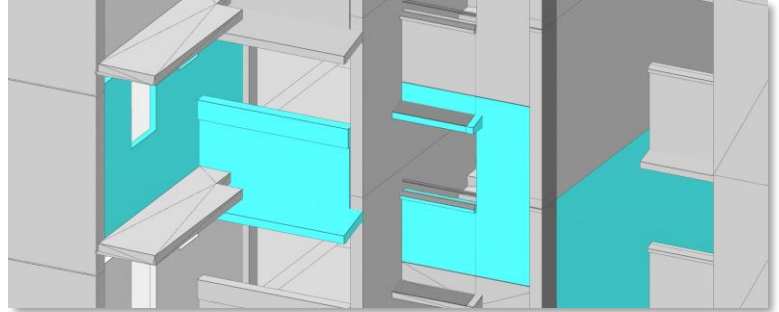

S4 – Fig.112 : Various Wall Types in relation to Building

## ► Modelling Wall in IFC-SG

- All the wall elements shall be modelled in IFC-SG model with the necessary information required as stipulated in the tables below.
  - Typical wall are allowed to have same marks and design information. The marks and design information have to be embedded in every wall element.
  - Multiple wall elements shall be modelled from storey to storey for continuous wall.
  - Civil defence shelter wall will need to be indicated as “Yes” in IFC-SG parameter “ShelterUsage” and substantiate with civil defence shelter reinforcement details in 2D drawings.
- 2D detail drawings are allowed for any irregular or complex wall section (e.g. L shape wall, D wall, retaining wall, etc.) with the indication of drawing number in the IFC-SG parameter “ReferTo2DDetail”.

## ► Wall Dimension and Reinforcement Definition

Column Dimension and Reinforcement Definition	
<b>1</b>	QP may substantiate a set of 2D wall schedule drawings to present the orientation and arrangement of wall reinforcement for illustration.
<b>2</b>	The input for VerticalRebar & HorizontalRebar shall be "HXX-XXX" while "H" is a must, XX is the longitudinal reinforcement diameter and XXX is the spacing of longitudinal reinforcement. <ul style="list-style-type: none"> <li>• Use ‘2’ for similar reinforcement provided for 2 faces (e.g. 2H16-200)</li> <li>• Use ‘+’ for more than 1 layer of reinforcement</li> </ul> <div style="text-align: center;"> </div>
<b>3</b>	The input for Stirrups shall be “HXX-XXX-XXX” while “H” is a must, XX are the transverse reinforcement diameter, 1 <sup>st</sup> XXX is the longitudinal spacing of transverse reinforcement and 2 <sup>nd</sup> XXX is the transverse spacing of transverse reinforcement. <ul style="list-style-type: none"> <li>• Indicate the longitudinal spacing and follow with transverse spacing (e.g.H8-100-100)</li> </ul> <div style="text-align: center;"> </div>

## Wall

### ► Wall Dimension and Reinforcement Definition (continued from previous page)

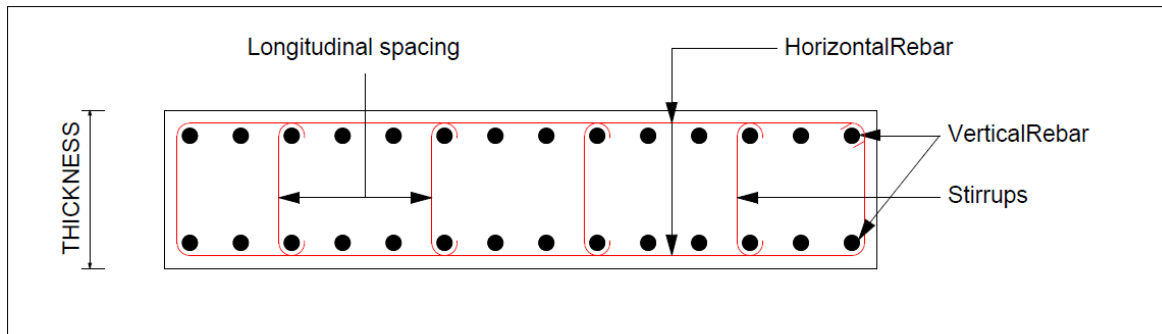

#### WALL REINFORCEMENT ANNOTATION

S4 – Fig 115 : Wall Reinforcement Annotation

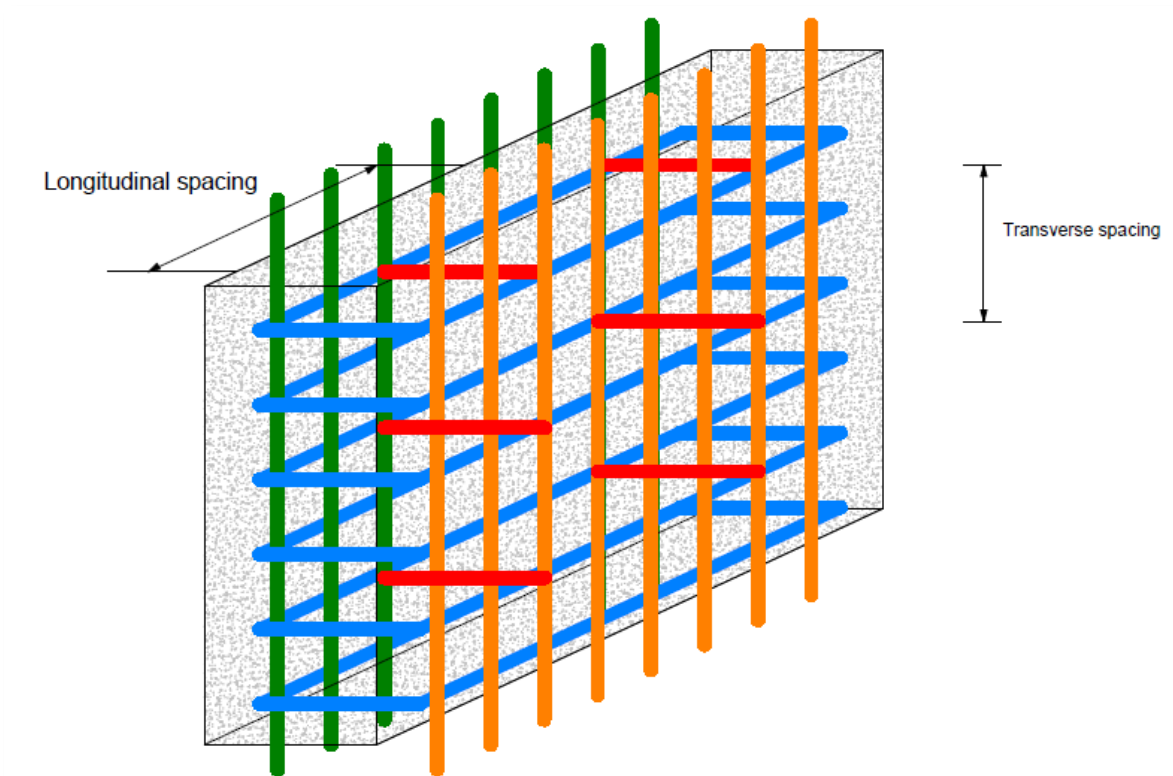

S4 – Fig 116 : Wall Reinforcement Annotation

# Wall

## ► L-Shape Wall

- Typical wall are allowed to have same marks and design information. The marks and design information have to be embedded in every wall element.

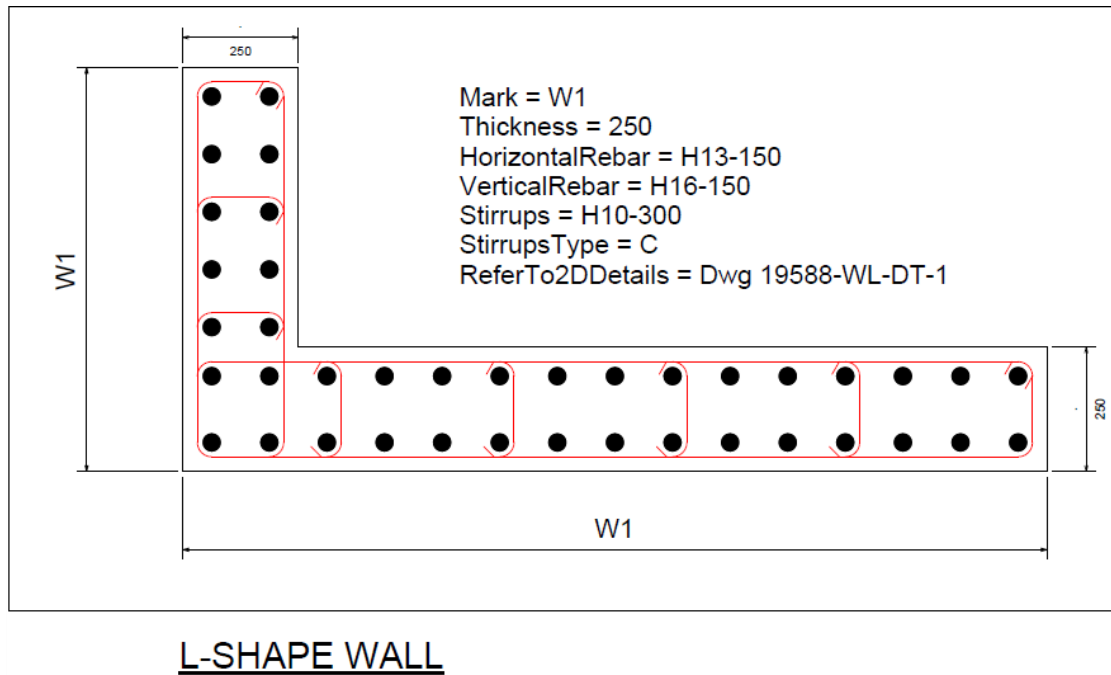

S4 – Fig 117 : L-Shape Wall

## ► L-Shape Wall with Different Thickness

- Different wall thickness should have different wall marks even the design information are the same.

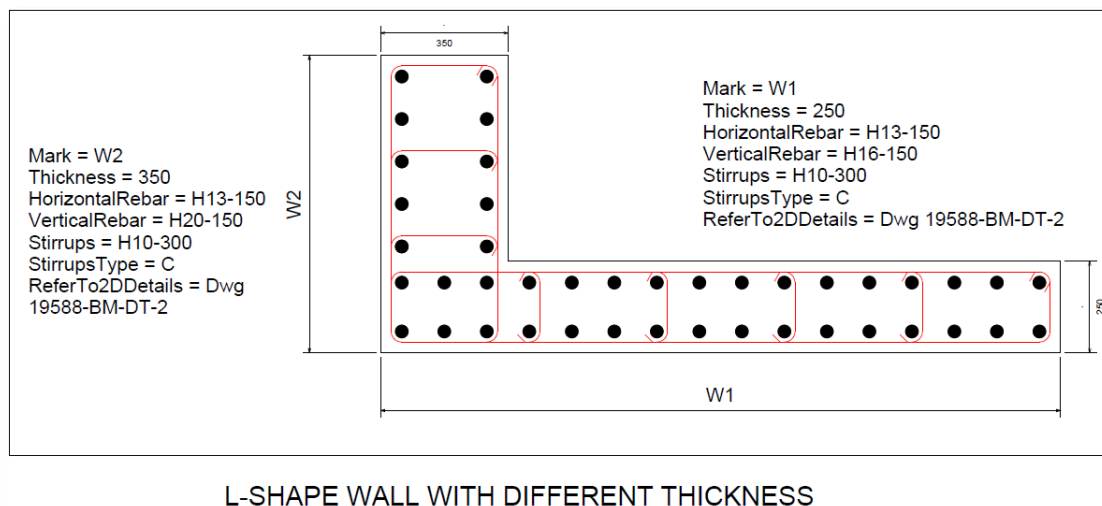

S4 – Fig 118 : L-Shape Wall with Different Thickness

# Wall

## ► By IFC Representation

IFC Entity: <b>IfcWall</b>						
IFC SubType: N.A., BOUNDARYWALL, PARAPET, RETAININGWALL						
S/N	IFC-SG Property	Property Type	Type of Elements	Unit	Input Limitation	Examples
1	MaterialGrade	Text	All walls	-	Yes	Refer to list <sup>^</sup>
2	ConstructionMethod	Text	All walls	-	Yes	Refer to list <sup>^</sup>
3	ReferTo2DDetail	Text	When required / relevant	-	No	Dwg Number
4	ReinforcementSteelGrade	Text	All walls	-	No	Refer to list <sup>^</sup>
5	ShelterUsage	Boolean	When required / relevant	-	Yes	TRUE / FALSE
6	Mark	Text	All walls	-	No	W1, W2
7	Thickness	Length	All walls	mm	No*	300
8	HorizontalRebar	Text	All walls	-	Yes	2H20-150
9	Stirrups	Text	All walls	-	Yes	H10-150-300
10	StirrupsType	Text	Optional	-	Yes	Refer to list <sup>^</sup>
11	VerticalRebar	Text	All walls	-	Yes	H32-150+H25-150
12	WorkingLoad_DAI-1	Integer	When required / relevant	kN	No	1234
13	WorkingLoad_DAI-2	Integer	When required / relevant	kN	No	1234
14	Accreditation_PAS	Boolean	-	-	Yes	TRUE / FALSE
15	LoadBearing	Boolean	-	-	Yes	TRUE / FALSE
16	MechanicalConnectionType	Text	-	-	No	Flexible Loops
17	PrefabricatedReinforcement Cage	Boolean	-	-	Yes	TRUE / FALSE
18	IsPartyWall	Boolean	-	-	Yes	TRUE / FALSE
19	IsExternal	Boolean	-	-	Yes	TRUE / FALSE
20	BeamFacade	Boolean	-	-	Yes	TRUE / FALSE
21	DoubleBayFacade	Boolean	-	-	Yes	TRUE / FALSE
22	PrefinishedFacade	Boolean	-	-	Yes	TRUE / FALSE
23	ArrangementType	Text	-	-	Yes	Multi-Tier

\* Parameter is populated from the dimensions of BIM elements modelled.

<sup>^</sup> List can be found [here](#).

# Wall

## ► Household Shelter Wall

- Typical wall are allow to have same marks and design information. The marks and design information have to be embedded in every wall element.

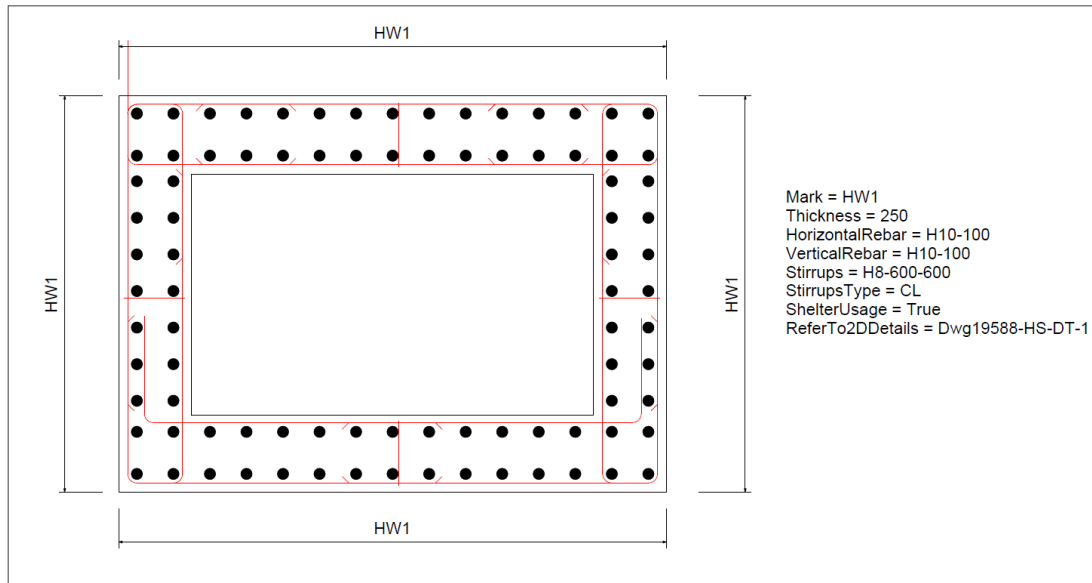

LANDED HOUSEHOLD SHELTER WALL LAYOUT

S4 – Fig 119 : Household Shelter Wall

## ► Example of Wall (RC Household Shelter Wall) Structural Element Input

250mm thick RC Precast Household Shelter Wall	IFC Entity: <b>IfcWall</b>		
	IFC SubType: N.A.		
<ul style="list-style-type: none"> <li>• Mark – HS1</li> <li>• Concrete grade C32/40</li> <li>• From 1<sup>st</sup> storey to 2<sup>nd</sup> storey</li> <li>• Vertical rebar H13-100</li> <li>• Horizontal rebar H13-100</li> <li>• Shear link H8-600</li> </ul>	S/N	IFC-SG Property	Examples
	1	MaterialGrade	C32/40
	2	ConstructionMethod	PC
	3	ReferTo2DDetail	Dwg 19588-HS-DT-1
	4	ReinforcementSteelGrade	500B
	5	ShelterUsage	Yes
	6	Mark	HS1
	7	Thickness	250
	8	HorizontalRebar	H13-100
	9	Stirrups	H8-600-600
	10	StirrupsType	CL
11	VerticalRebar	H13-100	

## Waste Terminal

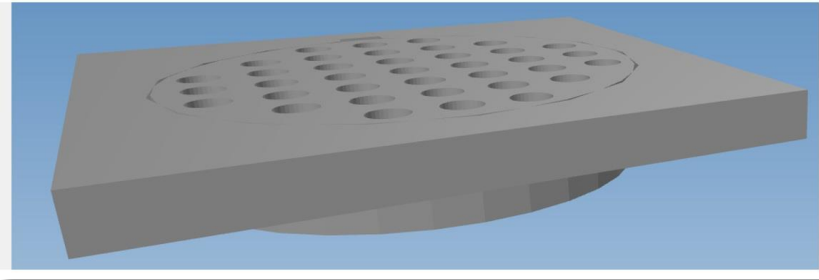

S4 – Fig 119: Floor Trap

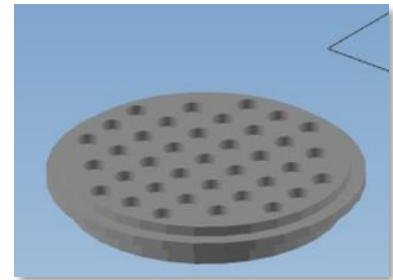

S4 – Fig 120: Floor Trap

### ► By IFC Representation

<b>IFC Entity:</b> <a href="#">IfcWasteTerminal</a>						
<b>IFC SubType:</b> FLOORTRAP, FLOORWASTE, GULLYSUMP, GULLYTRAP, WASTETRAP, WASTESUMP						
S/N	IFC-SG Property	Property Type	Type of Elements	Unit	Input Limitation	Examples
1	Material	Text	-	-	-	-
2	TradeEffluent	Boolean	-	-	Yes	TRUE / FALSE



## Water Meter

Legend: ■ Architecture ■ C&S ■ M&E

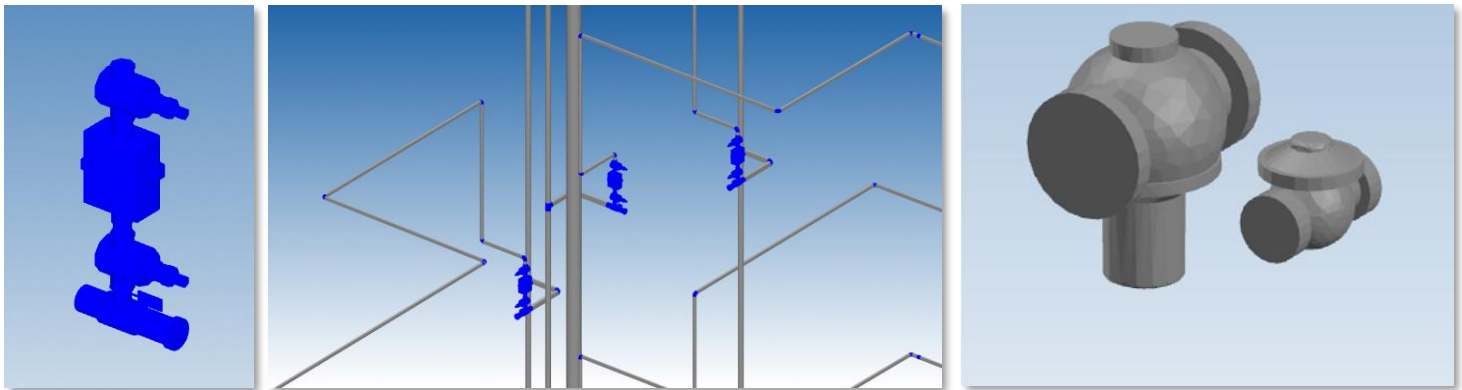

S4 – Fig 121 to 123 : Water Meter

### ► By IFC Representation

IFC Entity: <b>IfcFlowMeter</b>						
IFC SubType: WATERMETER						
S/N	IFC-SG Property	Property Type	Type of Elements	Unit	Input Limitation	Examples
1	Capacity	Volume	-	L	No	-
2	Diameter	Length	-	mm	No	-
3	Length	Length	-	mm	No	-
4	Purpose	Text	-	-	No	Private
5	UnitNumber	Text	-	-	-	-
6	UnitNumberTag	Boolean	-	-	Yes	TRUE / FALSE
7	WaterSupplySource	Text	-	-	-	-

## Window



S4 – Fig 125 : Window



S4 – Fig 126 : Window in relation to Building

### ► By IFC Representation

IFC Entity: <b>lfcWindow</b>						
IFC SubType: BAYWINDOW, VENTILATIONSLEEVE, LOUVRE, WINDOW						
S/N	IFC-SG Property	Property Type	Type of Elements	Unit	Input Limitation	Examples
1	InnerDiameter	Length	-	mm	No	N.A.
2	OuterDiameter	Length	-	mm	No	N.A.
3	FireAccessOpening	Boolean	-	N.A.	Yes	TRUE / FALSE
4	StructuralWidth	Length	-	mm	No	N.A.
5	StructuralHeight	Length	-	mm	No	N.A.
6	Material	Text	-	-	No	-
7	SafetyBarrierHeight	Real	-	-	-	-
8	OperationType	Text	-	-	-	-
9	PercentageOfOpening	Real	-	-	-	-

# Ready for CORENET X

Ready to make your first CORENET X submission? Go to <https://portal.corenet.gov.sg/> and register your latest project now!

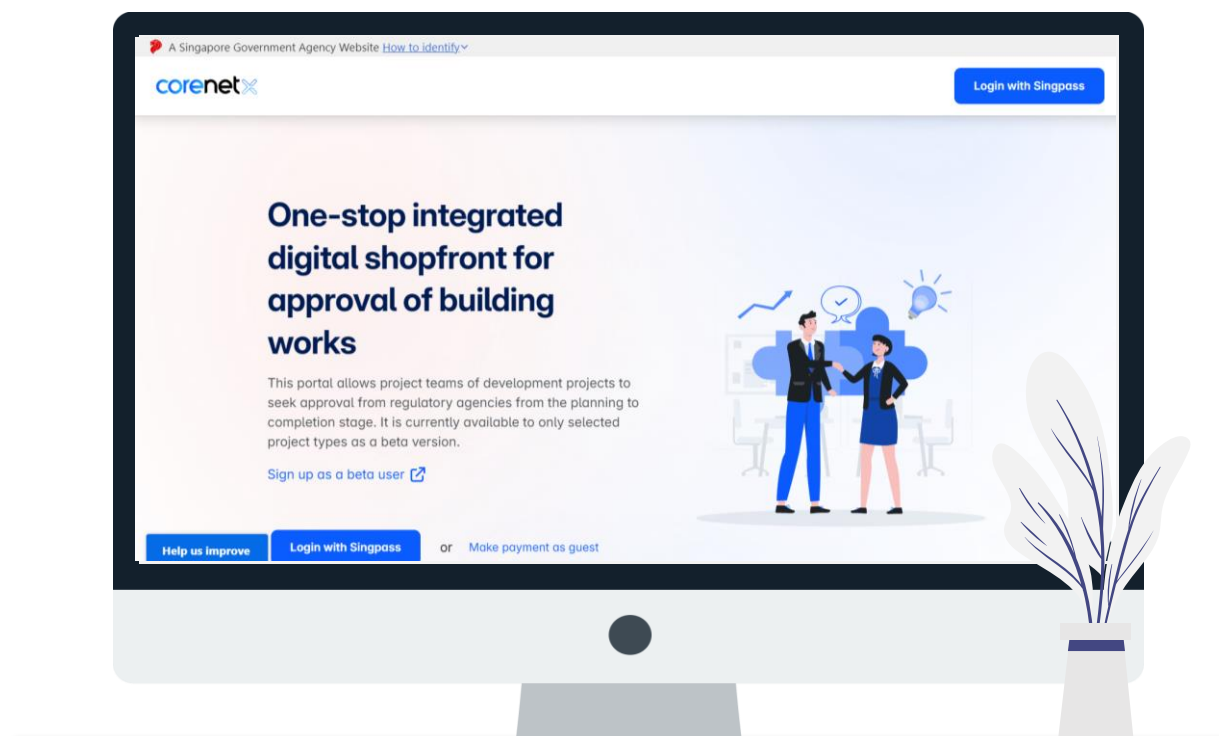

For more information, training and resources about CORENET X, access the CORENET X website at <https://go.gov.sg/cx>

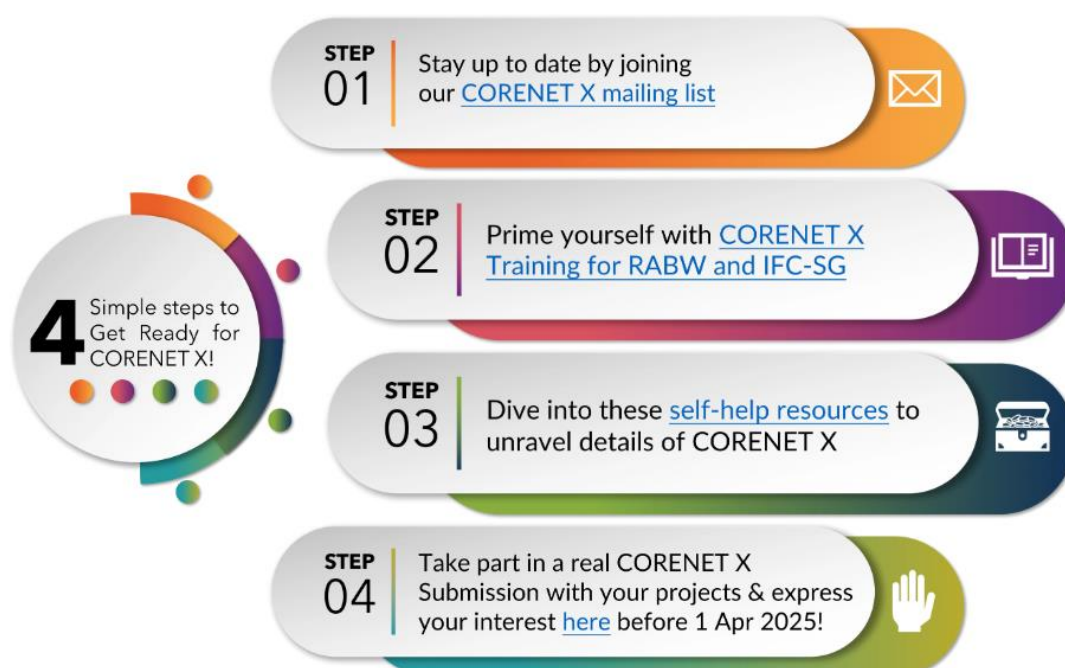



## Agencies

<b>Building and Construction Authority</b>	(BCA)
<b>Housing Development Board</b>	(HDB)
<b>JTC Corporation</b>	(JTC)
<b>Land Transport Authority</b>	(LTA)
<b>National Environment Agency</b>	(NEA)
<b>National Parks Board</b>	(NParks)
<b>Public Utilities Board</b>	(PUB)
<b>Singapore Civil Defence Force</b>	(SCDF)
<b>Singapore Land Authority</b>	(SLA)
<b>Urban Redevelopment Authority</b>	(URA)

## Industry Partners

**ADDP Architects LLP**  
**Alpha Consulting Engineers Pte Ltd**  
**BECA (Singapore)**  
**Belmacs**  
**City Developments Limited**  
**DCA Architects Pte Ltd**  
**DPA Architects Pte Ltd**  
**ECAS Consultants Pte Ltd**  
**ID Architects Pte Ltd**  
**Hoi Hup Realty Pte Ltd**  
**KCL Consultants Pte Ltd**  
**KTP Consultants Pte Ltd**  
**LSW Consulting Engineers Pte Ltd**  
**PDC Consultants Pte Ltd**  
**P&T Consultants Pte Ltd**  
**Squire Mech Pte Ltd**  
**Surbana Jurong Private Limited**  
**TWA**  
**TW-Asia Pte Ltd**  
**United Projects Consultants Pte Ltd**  
**VivATA Pte Ltd**

